



Service Guide

VLT® FC Series, D1h–D8h, Da2/Db2/Da4/Db4, E1h–E4h, J8/J9

VLT® HVAC Drive FC 102 • VLT® Refrigeration Drive FC 103 • VLT® AQUA Drive FC 202

VLT® AutomationDrive FC 302 • VLT® AutomationDrive FC 361 • VLT® Parallel Drive Modules



Contents

1 Introduction	9
1.1 Purpose of This Guide	9
1.2 Additional Resources	9
1.3 Abbreviations and Acronyms	10
1.4 Conventions	11
1.5 Document Version	11
1.6 Approvals and Certifications	11
1.7 Disposal	11
2 Safety	12
2.1 Introduction	12
2.2 Safety Symbols	12
2.3 Qualified Personnel	12
2.4 Safety Precautions	12
2.5 Electrostatic Discharge	14
3 Product Overview	15
3.1 Introduction	15
3.2 Tools Required	15
3.3 Service Report	15
3.4 Enclosure Size Identification	16
3.5 Enclosure Size Definitions	17
3.6 Product Views	22
3.6.1 Exploded View of D1h/D3h/D5h/D6h/J8 Drive	22
3.6.2 Exploded View of D2h/D4h/D7h/D8h/J9 Drive	23
3.6.3 Exploded View of Multi-Drive System	24
3.6.4 View of Control Shelf	25
3.6.5 Exploded View of Parallel Drive Module	26
3.6.6 View of Parallel Drive Module	27
3.6.7 Exploded View of E-sized Unit	28
3.7 Product Options	29
4 Operator Interface and Drive Control	30
4.1 Introduction	30
4.2 Local Control Panel	30
4.2.1 Layout	30
4.2.2 Menus	31
4.2.3 Parameter Settings	33
4.2.4 Uploading and Downloading Parameter Settings	33
4.2.5 Restoring Factory Default Settings	33

4.3 Status Messages	34
4.4 Status Message Definitions	34
4.5 Service Functions	37
4.6 Drive Inputs and Outputs	38
4.6.1 Input Signals	38
4.6.2 Output Signals	38
4.6.3 Control Supply	39
4.7 Control Terminals	39
4.8 Control Terminal Functions	40
4.9 Shielded Cable Grounding	41
5 Internal Drive Operation	42
5.1 Introduction	42
5.2 Description of Operation	42
5.2.1 Logic Section	44
5.2.2 Logic-to-power Interface	44
5.2.3 Power Section	45
5.3 Sequence of Operation	46
5.3.1 Rectifier Section	46
5.3.2 Intermediate Section	49
5.3.3 Inverter Section	52
5.3.4 Brake Option	55
5.3.5 Cooling Fans	57
5.3.6 Fan Speed Control	57
5.3.7 Load Sharing and Regen	58
5.3.8 Specific Power Card Connections	59
6 Troubleshooting	60
6.1 Troubleshooting Tips	60
6.2 Exterior Fault Troubleshooting	60
6.3 Fault Symptom Troubleshooting	60
6.4 Visual Inspection	61
6.5 Fault Symptoms	62
6.5.1 No Display	62
6.5.2 Intermittent Display	62
6.5.3 Motor Does Not Run	62
6.5.4 Incorrect Motor Operation	62
6.6 Alarms and Warnings	63
6.6.1 Overview of Alarms and Warnings	63
6.6.2 Alarm/Warning Identification Tables	64
6.7 Alarm and Warning Definitions	68

7 Drive and Motor Applications	80
7.1 Torque Limit, Current Limit, and Unstable Motor Operation	80
7.1.1 Overvoltage Trips	81
7.1.2 Mains Phase Loss Trips	81
7.1.3 Control Logic Problems	82
7.1.4 Programming Problems	82
7.1.5 Motor Load Problems	82
7.2 Internal Drive Problems	83
7.2.1 Overtemperature Faults	83
7.2.2 Current Sensor Faults	83
7.3 Electromagnetic Compatibility	83
7.3.1 Effects of EMI	83
7.3.2 EMI Signal and Power Wiring	84
7.3.3 Sources of EMI	84
7.3.4 EMI Propagation	84
7.3.5 Preventive Measures	87
8 Test Procedures	89
8.1 Introduction	89
8.2 Tools Required	90
8.2.1 Special Test Equipment	90
8.2.2 Signal Test Board	90
8.2.3 Metering Tools	91
8.3 Test Preparations	91
8.3.1 Preparations for Parallel Drive Systems	92
8.3.2 Access to Testing Connection Points	92
8.3.3 Card Connectors	93
8.3.4 Power Card in D-sized Drives	94
8.3.5 Power Card in E-sized Drives	95
8.3.6 MDCIC in Parallel Drive Systems	96
8.3.7 Fan Power Card in E-sized Drives	97
8.3.8 Gate Drive Card in D-sized Drives	98
8.3.9 Gate Drive Card in E-sized Drives	99
8.4 Static Test Procedures	100
8.4.1 Rectifier Circuits Test	100
8.4.2 Inverter Section Tests	101
8.4.3 Brake IGBT Test	101
8.4.4 Intermediate Section Tests	102
8.4.5 IGBT Temperature Sensor Test	102
8.4.6 Gate Resistor Test	103

8.4.7 Mains Fuse/DC Fuse Test	103
8.4.8 Disconnect Test	103
8.4.9 Circuit Breaker Test	104
8.4.10 Contactor Test	104
8.5 Dynamic Test Procedures	105
8.5.1 No Display Test	107
8.5.2 Input Voltage Test	107
8.5.3 Basic Control Card Voltage Test	107
8.5.4 DC Bus Voltage Test	107
8.5.5 Switch Mode Power Supply Test	108
8.5.6 Input Imbalance of Supply Voltage Test	108
8.5.7 Input Waveform Test	109
8.5.8 Input SCR Test	109
8.5.9 Output Imbalance of Motor Voltage and Current	110
8.5.10 IGBT Switching Test	111
8.5.11 IGBT Gate Drive Signals Test	112
8.5.12 Current Sensors Test	114
8.5.13 Fan Tests	116
8.5.14 Input Terminal Signal Tests	117
8.6 After-repair Tests	118
8.6.1 After-repair Tests for D-sized and E-sized Drives	119
8.6.2 After-repair Tests for Parallel Drive Systems	119
9 Special Test Equipment	120
9.1 Split Bus Power Supply	120
9.1.1 Overview	120
9.1.2 Split Bus Power Supply Diagrams	120
9.1.3 Split Bus Power Supply Connection	122
9.2 Parallel Drive Module Service Kit	122
9.2.1 Overview	122
9.2.2 Split Bus Power Supply and Parallel Drive Modules	124
9.2.3 After-test Installation of Parallel Drive Modules	125
9.2.4 Programming the Parallel Drive Module	125
9.2.5 Service Kit Troubleshooting	125
9.3 Signal Test Board	125
9.3.1 Signal Test Board	125
9.3.2 Signal Test Board Pin Outs	126
10 D1h/D3h/D5h/D6h/J8 Drive Disassembly and Assembly	129
10.1 Before Proceeding	129

10.2 D1h/D3h/D5h/D6h/J8 Disassembly and Assembly	130
10.2.1 General Information	130
10.2.2 Control Card and Control Card Mounting Plate	130
10.2.3 Power Card Mounting Plate	132
10.2.4 Power Card	134
10.2.5 AC Input Busbars	136
10.2.6 Mains Input Terminal Block	138
10.2.7 Motor Terminal Block	140
10.2.8 Brake Terminal Block (Optional)	141
10.2.9 Power Terminal Mounting Plate	141
10.2.10 Mixing Fan	142
10.2.11 Current Sensors	144
10.2.12 Balance/High Frequency Card	146
10.2.13 DC Bus Rails	147
10.2.14 Inrush Card	148
10.2.15 SCR Input Busbars	150
10.2.16 SCRs	150
10.2.17 Gate Drive Card	152
10.2.18 Brake IGBT Module	152
10.2.19 IGBTs	154
10.2.20 Standard DC Capacitors	156
10.2.21 Standard DC Capacitor Bank Layouts	162
10.2.22 Twistlock DC Capacitors	164
10.2.23 Twistlock DC Capacitor Bank Layouts	168
10.2.24 Heat Sink Fan	170
10.2.25 Door Fan	173
10.2.26 Top Fan	175
10.3 D5h/D6h Disassembly and Assembly	178
10.3.1 Accessing the Heat Sink Fan in D5h/D6h Drives	178
10.3.2 Removing the Drive from the Extended Options Cabinet	180
10.3.3 Contactor	182
10.3.4 Disconnect	182
10.4 Heat Sink Access Panel	184
10.4.1 Removing the Heat Sink Access Panel	184
11 D2h/D4h/D7h/D8h/J9 Unit Disassembly and Assembly	186
11.1 Before Proceeding	186
11.2 D2h/D4h/D7h/D8h/J9 Disassembly and Assembly	187
11.2.1 General Information	187
11.2.2 Control Card and Control Card Mounting Plate	188
11.2.3 Power Card Mounting Plate	190

11.2.4 Power Card	190
11.2.5 AC Input Busbars	192
11.2.6 Mains Input Terminal Block	194
11.2.7 EMC Shield	196
11.2.8 Brake Terminal Block (Optional)	196
11.2.9 Motor Terminal Block	197
11.2.10 Mixing Fan	198
11.2.11 Power Terminal Mounting Plate	200
11.2.12 Current Sensors	201
11.2.13 Balance/High Frequency Card	203
11.2.14 Gate Drive Card	205
11.2.15 Inrush Card	207
11.2.16 SCR Input Busbars	209
11.2.17 SCRs	209
11.2.18 DC Bus Rails	211
11.2.19 IGBTs	214
11.2.20 Standard DC Capacitors	216
11.2.21 Standard DC Capacitor Bank Layouts	220
11.2.22 Twistlock DC Capacitors	224
11.2.23 Twistlock DC Capacitor Bank Layouts	228
11.2.24 Brake IGBT Module	230
11.2.25 Heat Sink Fan	232
11.2.26 Door Fan	235
11.2.27 Top Fan	237
11.3 D7h/D8h Disassembly and Assembly	240
11.3.1 Removing the Drive from the Extended Options Cabinet	240
11.3.2 Accessing the Heat Sink Fan in D7h/D8h Drives	240
11.3.3 Contactor	242
11.3.4 Disconnect	242
11.4 Heat Sink Access Panel	244
11.4.1 Removing the Heat Sink Access Panel	244
12 Da2/Db2/Da4/Db4 Parallel System Disassembly and Assembly	246
12.1 Before Proceeding	246
12.1.1 Lifting the Unit	247
12.2 Parallel Drive System Disassembly and Assembly	249
12.2.1 Removing the Control Shelf	249
12.2.2 Removing a Drive Module	250
12.2.3 Installing the Drive Modules	251
12.2.4 Installing the Control Shelf	253
12.3 Parallel Drive Module Disassembly and Assembly	255

12.3.1 General Information	255
12.3.2 Blank Mounting Plate	257
13 E1h–E4h Drive Disassembly and Assembly	259
13.1 Before Proceeding	259
13.2 E1h–E4h Disassembly and Assembly	260
13.2.1 General Information	260
13.2.2 Control Card and Control Card Mounting Plate	261
13.2.3 Power Card Mounting Plate	263
13.2.4 Power Card	265
13.2.5 Fan Power Card	267
13.2.6 Inrush Card	269
13.2.7 Inrush Card Frame and Rectifier Bus Plates	271
13.2.8 SCR/Diode Modules	273
13.2.9 Input Plate with Busbars	275
13.2.10 Split Input Plate with Options	277
13.2.11 Input Plate Mixing Fan	279
13.2.12 Power Card Mixing Fan	281
13.2.13 Gate Drive Card Mounting Plate	283
13.2.14 Gate Drive Card	285
13.2.15 Current Sensors	287
13.2.16 Motor Busbar Assembly	289
13.2.17 Balance/High Frequency Card	291
13.2.18 Heat Sink Fan	293
13.2.19 DC Snubber Capacitors	295
13.2.20 Twistlock DC Capacitors	297
13.2.21 DC Capacitor Layouts	301
13.2.22 IGBTs	305
13.2.23 Door Fan	307
13.2.24 Top Fan	309
13.2.25 Vertical Brake Busbars	311
13.2.26 Horizontal Brake Busbars	313
13.2.27 DC Bus Rails	317
14 Product Specifications	319
14.1 Fastener Torque Ratings	319
14.1.1 General Torque Tightening Values	319
14.1.2 Unique Torque Values in E1h–E4h Drives	320
14.2 DC Voltage Levels	321
14.3 Warning and Alarm Trips Points	321

15 Spare Parts	323
15.1.1 Using the Drive Configurator Tool	323
15.1.2 Spare Parts Lists	323
15.1.3 Recommended Current Scaling Cards	324
16 Block Diagrams	356
Index	362

1 Introduction

1.1 Purpose of This Guide

This guide provides service information for the following drives and drive modules:

- D1h–D8h drives.
- E1h–E4 drives.
- J8–J9 drives.
- VLT® Parallel Drive Modules.
- Da2/Db2/Da4/Db4 parallel drive systems and VLT® Parallel Drive Modules.
- Drive modules within D9h–D10h/E5h–E6h enclosed drive systems. The drive modules within these enclosed drive systems are based on D3h–D4h and E3h–E4h drives.

It is intended to be used by authorized technicians to identify faults and perform repairs.

The guide includes the following information:

- Data for the different enclosure sizes.
- Description of user interfaces and internal processing.
- Troubleshooting and test instructions.
- Disassembly and reassembly instructions.

VLT® is a registered trademark.

1.2 Additional Resources

Additional resources are available to understand advanced drive functions and programming.

- The *Service Guide for Enclosures D9h–D10h and E5h–E6h* provides additional information for servicing D9h–D10h and E5h–E6h enclosed drive systems. (However, the drive modules within these enclosed drive systems are based on D3h–D4h and E3h–E4h drives, which are documented in the current manual.)
- The *VLT® Parallel Drive Modules Installation Guide* provides information required for mechanical and electrical installation of the VLT® Parallel Drive Modules.
- The *VLT® Parallel Drive Modules User Guide* provides detailed information for start-up and commissioning of parallel drive systems composed of VLT® Parallel Drive Modules.
- The product-specific *programming guide* provides greater detail on working with parameters and shows many application examples.
- The product-specific *design guide* provides detailed capabilities and functionality to design systems using Danfoss drives.
- The product-specific *operating guide* provides information required to install and commission Danfoss drives.
- The product-specific *kit instructions* provide information on installation of various options available for Danfoss drives.
- Technical documentation for other product options is available at drives.danfoss.com/knowledge-center/technical-documentation/.

1.3 Abbreviations and Acronyms

°C	Degrees Celsius
°F	Degrees Fahrenheit
Ω	Ohm
AC	Alternating current
ACP	Application control processor
AWG	American wire gauge
AMA	Automatic motor adaptation
CPU	Central processing unit
CSIV	Customer-specific initialization values
CT	Current transformer
DC	Direct current
DVM	Digital voltmeter
EEPROM	Electrically erasable programmable read-only memory
EMC	Electromagnetic compatibility
EMI	Electromagnetic interference
ESD	Electrostatic discharge
ETR	Electronic thermal relay
$f_{M,N}$	Nominal motor frequency
FC	Frequency converter
FPC	Fan power card
HF	High frequency
HVAC	Heating, ventilation, and air conditioning
Hz	Hertz
I_{LIM}	Current limit
I_{INV}	Rated inverter output current
$I_{M,N}$	Nominal motor current
$I_{VLT,MAX}$	Maximum output current
$I_{VLT,N}$	Rated output current supplied by the drive
IEC	International electrotechnical commission
IGBT	Insulated-gate bipolar transistor
I/O	Input/output
IP	Ingress protection
kHz	Kilohertz
kW	Kilowatt
L_d	Motor d-axis inductance
L_q	Motor q-axis inductance
LC	Inductor-capacitor
LCP	Local control panel
LED	Light-emitting diode
LOP	Local operation pad
mA	Milliamp
MCB	Miniature circuit breakers
MCO	Motion control option
MCP	Motor control processor
MCT	Motion control tool
MDCIC	Multi-drive control interface card
mV	Millivolts
NEMA	National Electrical Manufacturers Association
NTC	Negative temperature coefficient
$P_{M,N}$	Nominal motor power
PCB	Printed circuit board

PE	Protective earth
PELV	Protective extra low voltage
PID	Proportional integral derivative
PLC	Programmable logic controller
P/N	Part number
PROM	Programmable read-only memory
PS	Power section
PTC	Positive temperature coefficient
PWM	Pulse width modulation
R_s	Stator resistance
RAM	Random-access memory
RCD	Residual current device
Regen	Regenerative terminals
RFI	Radio frequency interference
RMS	Root means square (cyclically alternating electric current)
RPM	Revolutions per minute
SCR	Silicon controlled rectifier
SMPS	Switch mode power supply
S/N	Serial number
STO	Safe Torque Off
T_{LIM}	Torque limit
$U_{M,N}$	Nominal motor voltage
V	Volt
VVC	Voltage vector control
X_h	Motor main reactance

Table 1.1 Abbreviations, Acronyms, and Symbols

1.4 Conventions

- Numbered lists indicate procedures.
- Bulleted lists indicate other information.
- Italicized text indicates the following:
 - Cross-reference
 - Link
 - Parameter name
 - Parameter option
 - Parameter group name
- All dimensions in drawings are in mm (inch).
- An asterisk (*) indicates default setting of a parameter.

1.5 Document Version

This guide is regularly reviewed and updated. All suggestions for improvement are welcome. *Table 1.2* shows the document version and comments about changes made to the edition.

Edition	Remarks
MG94A5xx	Updated procedures and illustrations for D1h–D8h drives. Added content for J8–J9 drives, D9h–D10h/E5h–E6h drive modules, and data for 200–240 V (T2) drives.

Table 1.2 Document Version

1.6 Approvals and Certifications

The following list is a selection of possible type approvals and certifications for Danfoss drives:

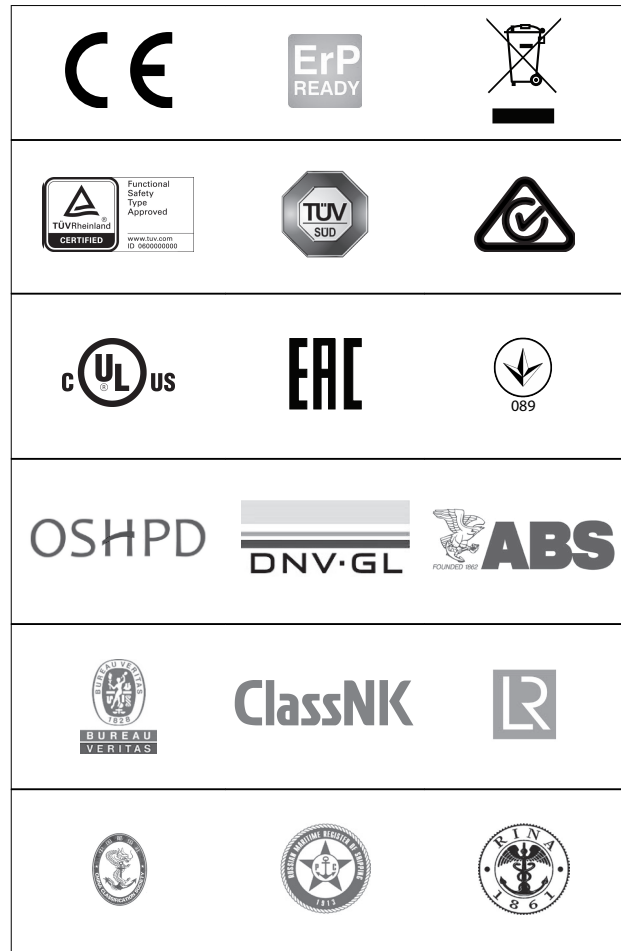

NOTICE

The specific approvals and certification for the drive can be found on the nameplate. For more information, contact the local Danfoss office or partner.

For more information on UL 508C thermal memory retention requirements, refer to the section *Motor Thermal Protection* in the product-specific *design guide*.

For more information on compliance with the European Agreement concerning International Carriage of Dangerous Goods by Inland Waterways (ADN), refer to section *ADN-compliant Installation* in the product-specific *design guide*.

1.7 Disposal

	<p>Do not dispose of equipment containing electrical components together with domestic waste.</p> <p>Collect it separately in accordance with local and currently valid legislation.</p>
--	--

2

2 Safety

2.1 Introduction

This section describes requirements to personnel and safe practices to observe when performing service and maintenance procedures.

2.2 Safety Symbols

The following symbols are used in this guide:

⚠ WARNING

Indicates a potentially hazardous situation that could result in death or serious injury.

⚠ CAUTION

Indicates a potentially hazardous situation that could result in minor or moderate injury. It can also be used to alert against unsafe practices.

NOTICE

Indicates important information, including situations that can result in damage to equipment or property.

2.3 Qualified Personnel

Correct and reliable transport, storage, installation, operation, and maintenance are required for the trouble-free and safe operation of the drive. Only qualified personnel are allowed to install or operate this equipment. Only authorized personnel are allowed to service and repair this equipment.

Qualified personnel are defined as trained staff, who are authorized to install, commission, and maintain equipment, systems, and circuits in accordance with pertinent laws and regulations. Also, the personnel must be familiar with the instructions and safety measures described in this manual.

Authorized personnel are qualified personnel, trained by Danfoss to service Danfoss products.

2.4 Safety Precautions

⚠ WARNING

HIGH VOLTAGE

Drives contain high voltage when connected to AC mains input, DC supply, load sharing, or permanent motors. Failure to use qualified personnel to install, start up, and maintain the drive can result in death or serious injury.

- Only qualified personnel must install, start up, and maintain the drive.

⚠ WARNING

UNINTENDED START

When the drive is connected to the AC mains, DC supply, or load sharing, the motor can start at any time. Unintended start during programming, service, or repair work can result in death, serious injury, or property damage. The motor can start with an external switch, a fieldbus command, an input reference signal from the LCP or LOP, via remote operation using MCT 10 Set-up Software, or after a cleared fault condition.

To prevent unintended motor start:

- Press [Off/Reset] on the LCP before programming parameters.
- Disconnect the drive from the mains.
- Completely wire and assemble the drive, motor, and any driven equipment before connecting the drive to the AC mains, DC supply, or load sharing.

⚠WARNING

DISCHARGE TIME

The drive contains DC-link capacitors, which can remain charged even when the drive is not powered. High voltage can be present even when the warning LED indicator lights are off. Failure to wait the specified time after power has been removed before performing service or repair work can result in death or serious injury.

- Stop the motor.
- Disconnect AC mains and remote DC-link power supplies, including battery back-ups, UPS, and DC-link connections to other drives.
- Disconnect or lock the motor.
- Disconnect any brake option.
- Disconnect any regen/load share option.
- Wait for the capacitors to discharge fully. The minimum waiting time is specified in the following discharge time table and is also visible on the drive label.
- Before performing any service or repair work, use an appropriate voltage measuring device to make sure that the capacitors are fully discharged. For parallel drive modules, measure DC-bus capacitor voltages before and after the individual DC fuses.

Enclosure Size	Minimum waiting time
D1h–D8h drives	20 minutes
J8–J9 drives	20 minutes
D9h–D10h enclosed drive systems	20 minutes
Da2/Da4/Db2/Db4 parallel drive systems	20 minutes
E1h–E4h drives	40 minutes
E5h–E6h enclosed drive systems	40 minutes

Table 2.1 Discharge Time

⚠WARNING

LEAKAGE CURRENT HAZARD

Leakage currents exceed 3.5 mA. Failure to ground the drive properly can result in death or serious injury.

- Ensure the correct grounding of the equipment by a certified electrical installer.

⚠WARNING

LOAD SHARE DISCONNECT

Load share is a connection between DC circuits of several drives, creating a multiple-drive system to run a single mechanical load. When servicing a drive that is part of a load share application:

- Turn off all drives in the system via a disconnect.
- Wait for the drives to discharge fully, using the longest waiting period required of the drives in the multi-drive system. Refer to the discharge time table for minimum waiting time.

⚠WARNING

EQUIPMENT HAZARD

Contact with rotating shafts and electrical equipment can result in death or serious injury.

- Ensure that only trained and qualified personnel install, start up, and maintain the drive.
- Ensure that electrical work conforms to national and local electrical codes.
- Follow the procedures in this guide.

⚠WARNING

UNINTENDED MOTOR ROTATION

WINDMILLING

Unintended rotation of permanent magnet motors creates voltage and can charge the unit, resulting in death, serious injury, or equipment damage.

- Ensure that permanent magnet motors are blocked to prevent unintended rotation.

⚠WARNING

SHOCK HAZARD AND RISK OF INJURY

For dynamic test procedures, mains input power is required, and all devices and supplies connected to mains are energized at rated voltage. Contact with powered components can result in death or serious injury.

- Do not touch energized parts of the drive when connected to mains.

⚠ WARNING**INTERNAL FAILURE HAZARD**

Under certain circumstances, an internal failure can cause a component to explode. Failure to keep the enclosure closed and properly secured can cause death or serious injury.

- Do not operate the drive with the door open or panels off.
- Ensure that the enclosure is properly closed and secured during operation.

⚠ WARNING**SHOCK HAZARD**

The drive can cause a DC current in the protective earth/ground (PE) conductor and thus result in death or serious injury.

- When a residual current-operated protective device (RCD) is used for protection against electrical shock, only an RCD of Type B is permitted on the supply side.

Failure to follow the recommendation means that the RCD cannot provide the intended protection.

⚠ CAUTION**RISK OF INJURY OR PROPERTY DAMAGE**

Do not assume that a motor is wired properly after completed service of the drive. Failure to perform these checks can result in personal injury, property damage, or less than optimal performance.

Check for:

- Loose connections.
- Improper programming.
- Added equipment.

⚠ CAUTION**HOT SURFACES**

The drive contains metal components that are still hot even after the drive has been powered off. Failure to observe the high temperature symbol (yellow triangle) on the drive can result in serious burns.

- Be aware that internal components, such as busbars, can be extremely hot even after the drive has been powered off.
- Exterior areas marked by the high-temperature symbol (yellow triangle) are hot while the drive is in use and immediately after being powered off.

NOTICE**MAINS SHIELD SAFETY OPTION**

A mains shield option is available for enclosures with a protection rating of IP21/IP54 (UL type 1/12). The mains shield is a cover installed inside the enclosure to protect against the unintended touch of the power terminals, according to BGV A2, VBG 4.

NOTICE**LIFTING - EQUIPMENT DAMAGE RISK**

Incorrect lifting can result in equipment damage.

- Use lifting lugs where provided.
- Prevent uncontrolled rotation.

2.5 Electrostatic Discharge

NOTICE**STATIC DISCHARGE**

When performing service, use proper Electrostatic Discharge (ESD) procedures to prevent damage to sensitive components.

NOTICE**AVOID TOUCH**

Do not touch components on the circuit boards. Hold circuit boards by the corners and edges only.

Many electronic components within the drive are sensitive to static electricity. Voltages so low that they cannot be felt, seen, or heard can reduce the life, affect performance, or completely destroy sensitive electronic components.

3 Product Overview

3.1 Introduction

The VLT® HVAC Drive series is designed for the HVAC market. These drives operate in variable torque mode or constant torque down to 15 Hz and include special features and options designed for fan and pump applications.

The VLT® Refrigeration Drive series is designed for use with refrigeration systems. These drives offer continuous variable speed control and provide energy savings in a range of applications including pumps, fans, compressors, condensers, and evaporators.

The VLT® AQUA Drive series is designed for water and waste water markets. These drives can operate in either constant torque or variable torque with limited overload capabilities. Their features and options make them suitable for various water pumping and processing applications.

The VLT® AutomationDrive series is fully programmable for either constant torque or variable torque industrial applications. These drives operate various applications and incorporate a wide range of control and communication options.

These models are available in IP20 (protected chassis), IP21 (UL type 1), and IP54 (UL type 12) enclosures.

Special versions of these 3 drive types are available as VLT® Parallel Drive Modules in IP00 enclosures. They are used by panel builders to create 2-module or 4-module systems.

NOTICE

PARALLEL MODULE CONFIGURATION

VLT® Parallel Drive Modules have specialized software and hardware configurations that differ from standalone D-sized units. To avoid equipment malfunction, never attempt to replace standalone modules with VLT® Parallel Drive Modules.

3.2 Tools Required

Item	Description
ESD protection kit	Wrist strap and mat
Metric socket set	7–19 mm
Socket extensions	100–150 mm (4 in and 6 in)
Magnetic sockets	–
Ratchet wrench	–
Torque wrench	Torque range 0.5–19 Nm (6–170 in-lb)
Torx driver set	T10–T50
Needle nose pliers	–
Screwdrivers	Standard and Phillips

Table 3.1 Tools Required

Item	Description
Digital Volt-Ohm Meter (PWM-compatible)	<ul style="list-style-type: none"> Rated for true RMS. Rated for the mains AC voltage and DC-link voltage of the drive. (DC-link voltage = 1.414 x mains voltage). Supports the diode mode.
Analog voltmeter (with safety probe tip extenders)	–
Oscilloscope	–
Clamp-on ammeter	Rated for true RMS
Split bus power supply	p/n 130B3146
Signal test board	p/n 176F8437
Parallel drive module service kit ¹⁾	p/n 176F3745

Table 3.2 Instruments Recommended to Test Drives

1) Used for testing only VLT® Parallel Drive Modules.

3.3 Service Report

Report the serial number (S/N) of the drive when requesting support, or preparing the service report. The serial number is listed on the nameplate. Refer to *Illustration 3.1* for details.

3.4 Enclosure Size Identification

Enclosure size is used throughout this guide whenever procedures or components differ between drives based on physical size. This service guide includes the enclosure sizes listed in *Table 3.3*.

Enclosure size	Power rating
D1h–D8h drives	90–400 kW
E1h–E4h drives	315–710 kW
J8–J9 drives	90–315 kW
Da2/Db2/Da4/Db4 parallel drive systems	250–1200 kW
Drives modules in D9h–D10h and E5h–E6h enclosed drive systems	315–800 kW

Table 3.3 Enclosure Size Overview

Find the enclosure size using the following steps:

1. Locate the nameplate label:
 - 1a In parallel drive systems, the label is found on the control shelf to the lower right of the local control panel (LCP). See *Illustration 3.5*.
 - 1b For drives in enclosure sizes D1h–D8h, E1h–E4h and J8–J9, the label is found inside the drive enclosure.
2. Obtain the following information from the type code on the nameplate. Refer to *Illustration 3.1*.
 - 2a Product group and drive series (characters 1–6)
 - 2b Power rating (characters 7–10)
 - 2c Voltage rating (phases and mains) (characters 11–12)
 - 2d Type of drive (character 16). If the character “P” is shown, note character 17 as well.
3. Find the appropriate voltage rating table for the product group and drive series. Refer to *chapter 3.5 Enclosure Size Definitions*. For example, T4 for FC 102 and FC 202.
4. Within the table, find the power rating and look up the type of drive.

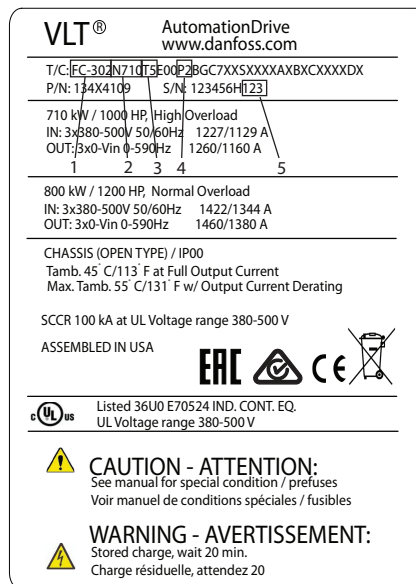
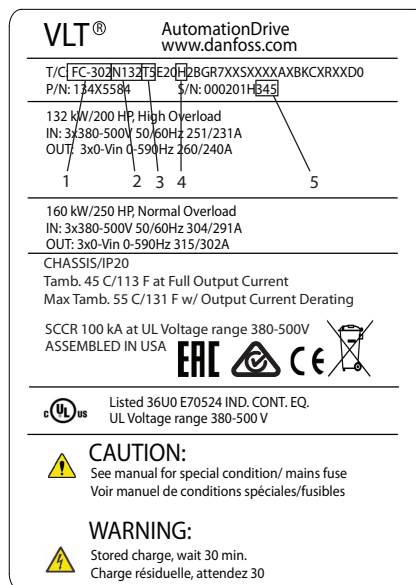

1	Product group and drive series
2	Power rating
3	Voltage rating (phases and mains)
4	Drive type: H = 6-pulse drive P2 = 6-pulse, class A2 RFI P4 = 6-pulse, class A1 RFI P6 = 12-pulse, class A2 RFI P8 = 12-pulse, class A1 RFI
5	Build date (wwy, where ww = the week and y = last digit of the year). For example, 345 = week 34 of 2015.

Illustration 3.1 Sample Nameplates

130BF045.10

3.5 Enclosure Size Definitions

Power rating	Drive type	Enclosure size	Enclosure size with extended options cabinet	Number of drive modules
N55K	H	D1h/D3h	-	-
N75K	H	D1h/D3h	-	-
N90K	H	D2h/D4h	-	-
N110	H	D2h/D4h	-	-
N150	H	D2h/D4h	-	-
N160	H	D2h/D4h	-	-

Table 3.4 200–240 V AC (T2) Voltage Rating for FC 102, FC 103, and FC 202

Power rating	Drive type	Enclosure size	Enclosure size with extended options cabinet	Number of drive modules
N45K	H	D1h/D3h	-	-
N55K	H	D1h/D3h	-	-
N75K	H	D2h/D4h	-	-
N90K	H	D2h/D4h	-	-
N110	H	D2h/D4h	-	-
N150	H	D2h/D4h	-	-

Table 3.5 200–240 V AC (T2) Voltage Rating for FC 302

Power rating	Drive type	Enclosure size	Enclosure size with extended options cabinet	Number of drive modules
N110	H	D1h/D3h	D5h/D6h	–
N132	H	D1h/D3h	D5h/D6h	–
N160	H	D1h/D3h	D5h/D6h	–
N200	H	D2h/D4h	D7h/D8h	–
N250	H	D2h/D4h	D7h/D8h	–
N315	H	D2h/D4h	D7h/D8h	–
N315	P6/P8	Db2	–	2-module system
N355	P6/P8	Db2	–	2-module system
N355	H	E1h/E3h	–	–
N400	P6/P8	Db2	–	2-module system
N400	H	E1h/E3h	–	–
N450	P6/P8	Db2	–	2-module system
N450	H	E1h/E3h	–	–
N500	P2/P4	Da2	–	2-module system
N500	P6/P8	Db2	–	2-module system
N500	H	E2h/E4h	–	–
N560	P2/P4	Da4	–	4-module system
N560	P6/P8	Db4	–	4-module system
N560	H	E2h/E4h	–	–
N630	P2/P4	Da4	–	4-module system
N630	P6/P8	Db4	–	4-module system
N710	P2/P4	Da4	–	4-module system
N710	P6/P8	Db4	–	4-module system
N800	P2/P4	Da4	–	4-module system
N800	P6/P8	Db4	–	4-module system
N1000	P2/P4	Da4	–	4-module system
N1000	P6/P8	Db4	–	4-module system

Table 3.6 380–480 V AC (T4) Voltage Rating for FC 102, FC 103, and FC 202

Power rating	Drive type	Enclosure size	Enclosure size with extended options cabinet	Number of drive modules
N90K	H	J8	–	–
N110	H	J8	–	–
N132	H	J8	–	–
N160	H	J8	–	–
N200	H	J9	–	–
N250	H	J9	–	–
N315	H	J9	–	–

Table 3.7 380–480 V AC (T4) Voltage Rating for FC 361

Power rating	Drive type	Enclosure size	Enclosure size with extended options cabinet	Number of drive modules
N90K	H	D1h/D3h	D5h/D6h	-
N110	H	D1h/D3h	D5h/D6h	-
N132	H	D1h/D3h	D5h/D6h	-
N160	H	D2h/D4h	D7h/D8h	-
N200	H	D2h/D4h	D7h/D8h	-
N250	H	D2h/D4h	D7h/D8h	-
N250	P6/P8	Db2	-	2-module system
N315	P6/P8	Db2	-	2-module system
N315	H	E1h/E3h	-	-
N355	P6/P8	Db2	-	2-module system
N355	H	E1h/E3h	-	-
N400	P6/P8	Db2	-	2-module system
N400	H	E1h/E3h	-	-
N450	P2/P4	Da2	-	2-module system
N450	P6/P8	Db2	-	2-module system
N450	H	E2h/E4h	-	-
N500	P2/P4	Da4	-	4-module system
N500	P6/P8	Db4	-	4-module system
N500	H	E2h/E4h	-	-
N560	P2/P4	Da4	-	4-module system
N560	P6/P8	Db4	-	4-module system
N630	P2/P4	Da4	-	4-module system
N630	P6/P8	Db4	-	4-module system
N710	P2/P4	Da4	-	4-module system
N710	P6/P8	Db4	-	4-module system
N800	P2/P4	Da4	-	4-module system
N800	P6/P8	Db4	-	4-module system

Table 3.8 380–500 V AC (T5) Voltage Rating for FC 302

Power rating	Drive type	Enclosure size	Enclosure size with extended options cabinet	Number of drive modules
N75K	H	D1h/D3h	D5h/D6h	–
N90K	H	D1h/D3h	D5h/D6h	–
N110	H	D1h/D3h	D5h/D6h	–
N132	H	D1h/D3h	D5h/D6h	–
N160	H	D1h/D3h	D5h/D6h	–
N200	H	D2h/D4h	D7h/D8h	–
N250	H	D2h/D4h	D7h/D8h	–
N315	H	D2h/D4h	D7h/D8h	–
N315	P6	Db2	–	2-module system
N400	H	D2h/D4h	D7h/D8h	–
N400	P6	Db2	–	2-module system
N450	P6	Db2	–	2-module system
N450	H	E1h/E3h	–	–
N500	P6	Db2	–	2-module system
N500	H	E1h/E3h	–	–
N560	P6	Db2	–	2-module system
N560	H	E1h/E3h	–	–
N630	P6	Db2	–	2-module system
N630	H	E1h/E3h	–	–
N710	P2	Da4	–	4-module system
N710	P6	Db4	–	4-module system
N710	H	E2h/E4h	–	–
N800	P2	Da4	–	4-module system
N800	P6	Db4	–	4-module system
N800	H	E2h/E4h	–	–
N900	P2	Da4	–	4-module system
N900	P6	Db4	–	4-module system
N1M0	P2	Da4	–	4-module system
N1M0	P6	Db4	–	4-module system
N1M2	P2	Da4	–	4-module system
N1M2	P6	Db4	–	4-module system

Table 3.9 525–690 V AC (T7) Voltage Rating for FC 102, FC 103, and FC 202

Power rating	Drive type	Enclosure size	Enclosure size with extended options cabinet	Number of drive modules
N55K	H	D1h/D3h	D5h/D6h	-
N75K	H	D1h/D3h	D5h/D6h	-
N90K	H	D1h/D3h	D5h/D6h	-
N110	H	D1h/D3h	D5h/D6h	-
N132	H	D1h/D3h	D5h/D6h	-
N160	H	D2h/D4h	D7h/D8h	-
N200	H	D2h/D4h	D7h/D8h	-
N250	H	D2h/D4h	D7h/D8h	-
N250	P6	Db2	-	2-module system
N315	H	D2h/D4h	D7h/D8h	-
N315	P6	Db2	-	2-module system
N355	P6	Db2	-	2-module system
N355	H	E1h/E3h	-	-
N400	P6	Db2	-	2-module system
N400	H	E1h/E3h	-	-
N500	P6	Db2	-	2-module system
N500	H	E1h/E3h	-	-
N560	P6	Db2	-	2-module system
N560	H	E1h/E3h	-	-
N630	P2	Da4	-	4-module system
N630	P6	Db4	-	4-module system
N630	H	E2h/E4h	-	-
N710	P2	Da4	-	4-module system
N710	P6	Db4	-	4-module system
N710	H	E2h/E4h	-	-
N800	P2	Da4	-	4-module system
N800	P6	Db4	-	4-module system
N900	P2	Da4	-	4-module system
N900	P6	Db4	-	4-module system
N1M0	P2	Da4	-	4-module system
N1M0	P6	Db4	-	4-module system

Table 3.10 525–690 V AC (T7) Voltage Rating for FC 302

3.6 Product Views

3.6.1 Exploded View of D1h/D3h/D5h/D6h/J8 Drive

3

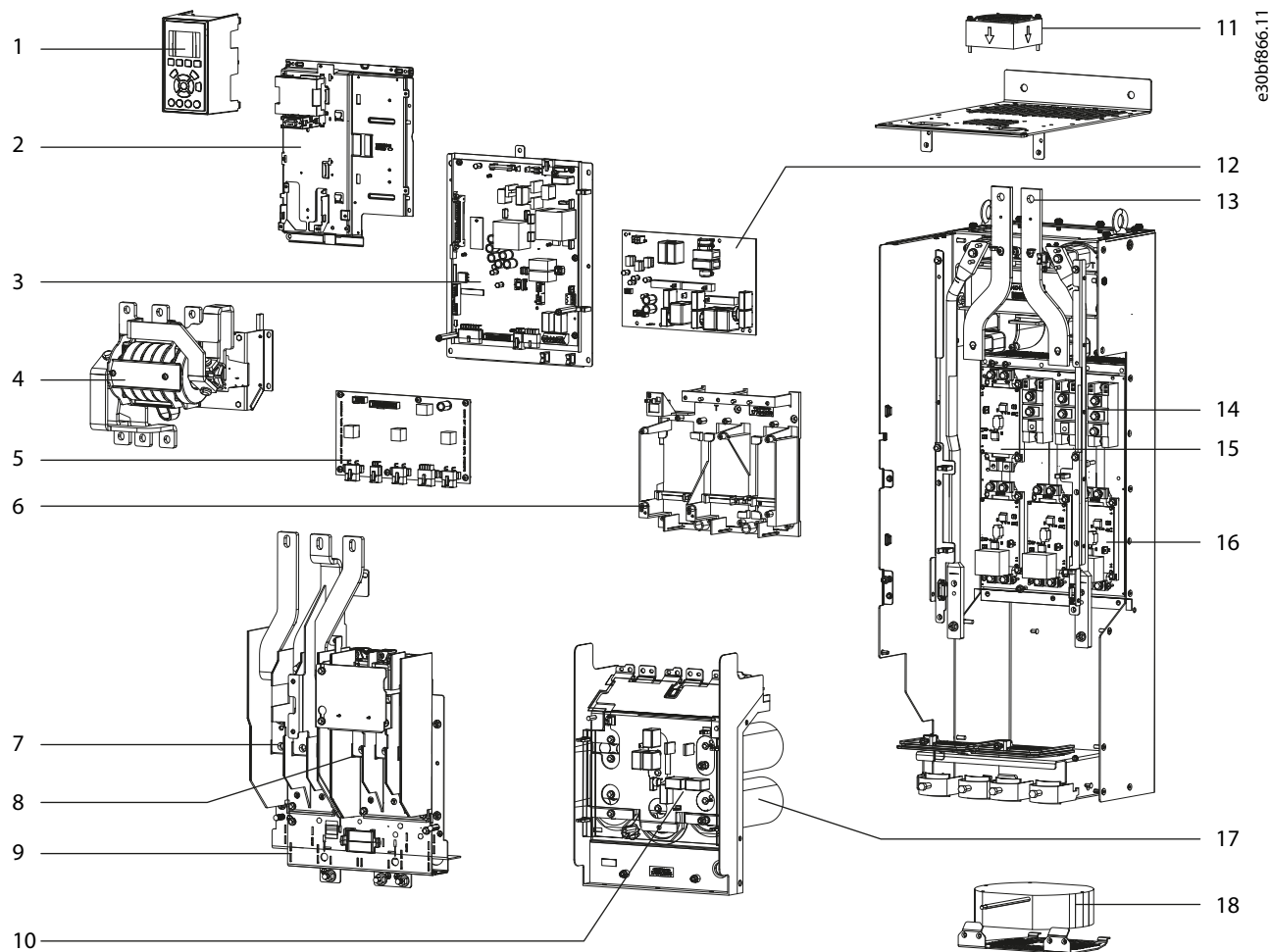

1	Local control panel (LCP) and bracket	10	Balance/high frequency card
2	Control card and mounting plate	11	Top fan (IP20 only)
3	Power card and mounting plate	12	Inrush card
4	RFI filter (optional)	13	Regen/load share terminals (optional)
5	Gate drive card	14	SCR/diode modules
6	Gate drive card support bracket	15	Brake IGBT module (optional)
7	Mains input terminals	16	IGBT modules
8	Motor output terminals	17	Capacitor bank
9	Power terminal mounting plate	18	Heat sink fan

Illustration 3.2 Exploded View D3h Drive (D1h/D5h/D6h/J8 Drives are Similar).

3.6.2 Exploded View of D2h/D4h/D7h/D8h/J9 Drive

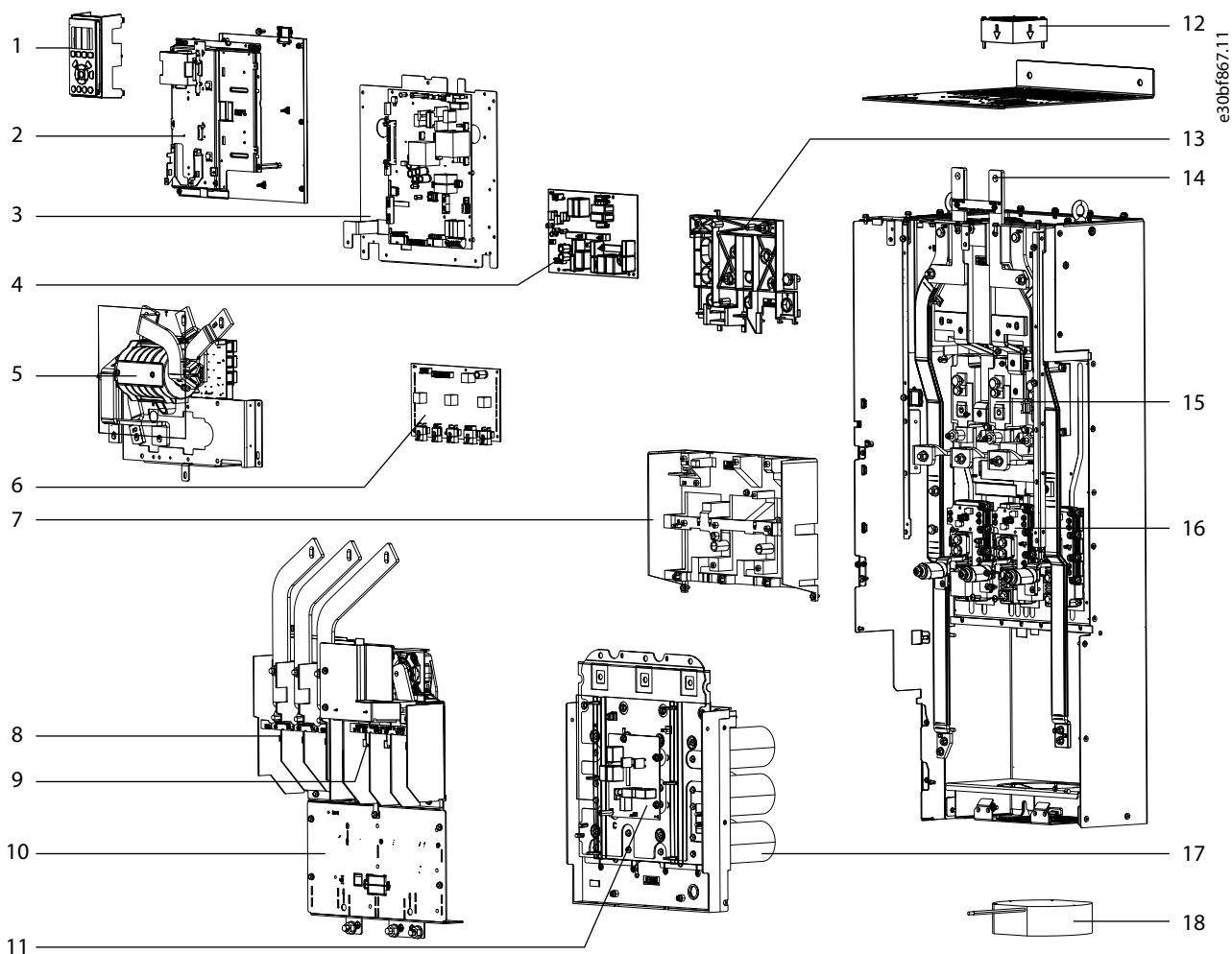

1	Local control panel and LCP cradle	10	Power terminal mounting plate
2	Control card and mounting plate	11	Balance/high frequency card
3	Power card and mounting plate	12	Top fan (IP20 only)
4	Inrush card	13	Inrush card bracket
5	RFI filter (optional)	14	Regen/load share terminals (optional)
6	Gate drive card	15	SCR/diode modules
7	Gate drive card support bracket	16	IGBT modules
8	Mains input terminals	17	Capacitor bank
9	Motor terminals	18	Heat sink fan

Illustration 3.3 Exploded View D4h Drive (D2h/D7h/D8h/J9 Drives are similar).

3.6.3 Exploded View of Multi-Drive System

This example of a 4-module system is composed of a control shelf and 4 VLT® Parallel Drive Modules in 2 side-by-side enclosures. The control shelf attaches to the enclosure and holds the LCP and control card, as well as the MDCIC and control terminals. Each module connects to the control shelf via a 44-pin ribbon cable. This example also includes an optional busbar kit and optional cooling duct kits.

3

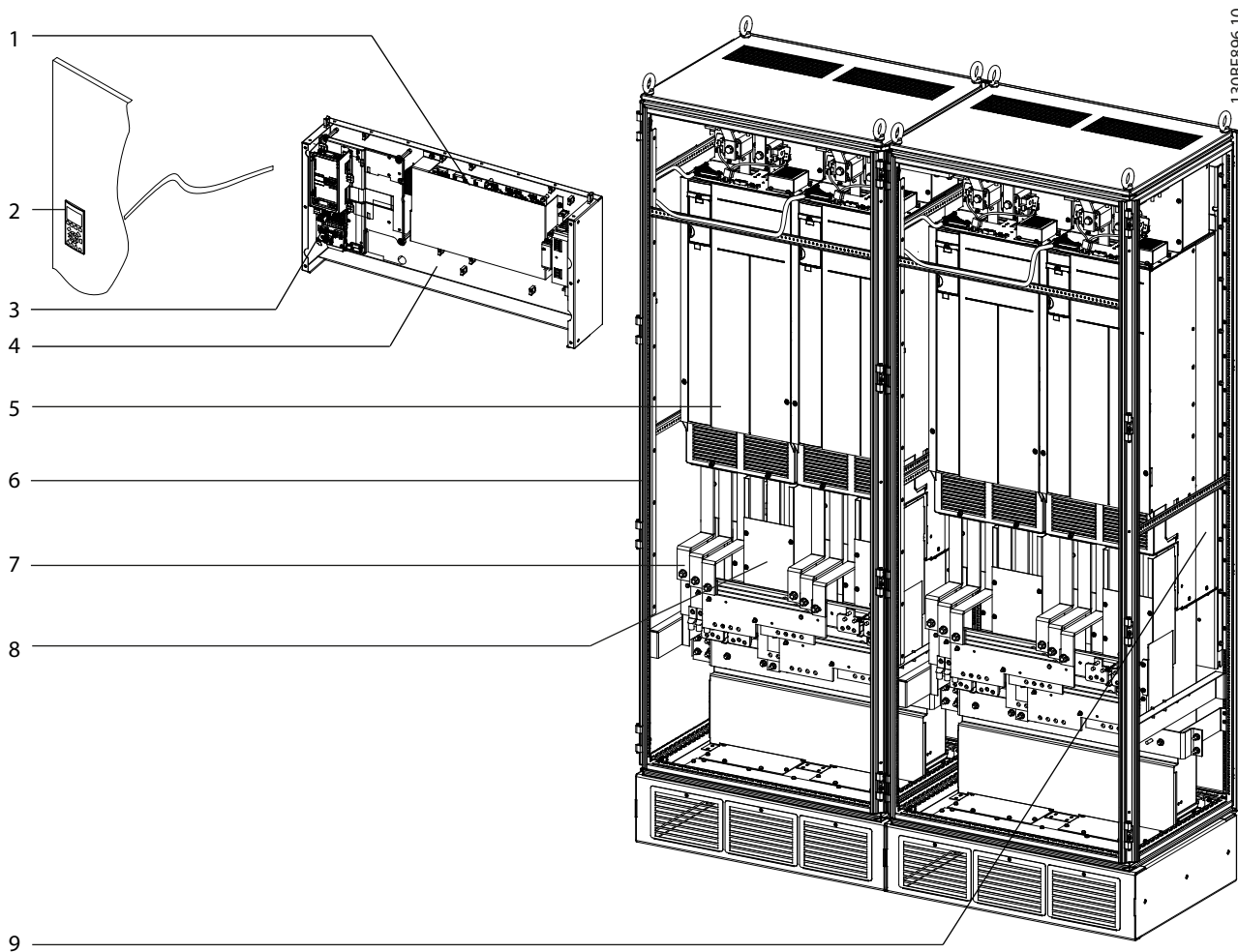

1	MDCIC (behind cover plate)	6	Enclosure
2	LCP and cable	7	Busbar kit (optional)
3	Control card	8	EMC Shield
4	Control shelf	9	Cooling kit (optional)
5	Drive module	–	–

Illustration 3.4 Exploded View of 4-module System

3.6.4 View of Control Shelf

Illustration 3.5 shows a control shelf with cables connecting it to 4 VLT® Parallel Drive Modules. The control shelf holds the LCP, MDCIC, and control terminals. The LCP shows alarm and warning messages and provides access to the system parameters. The MDCIC is connected to each of the drive modules via a 44-pin ribbon cable, and delivers control signals to the modules. The control card communicates with the MDCIC via a cable.

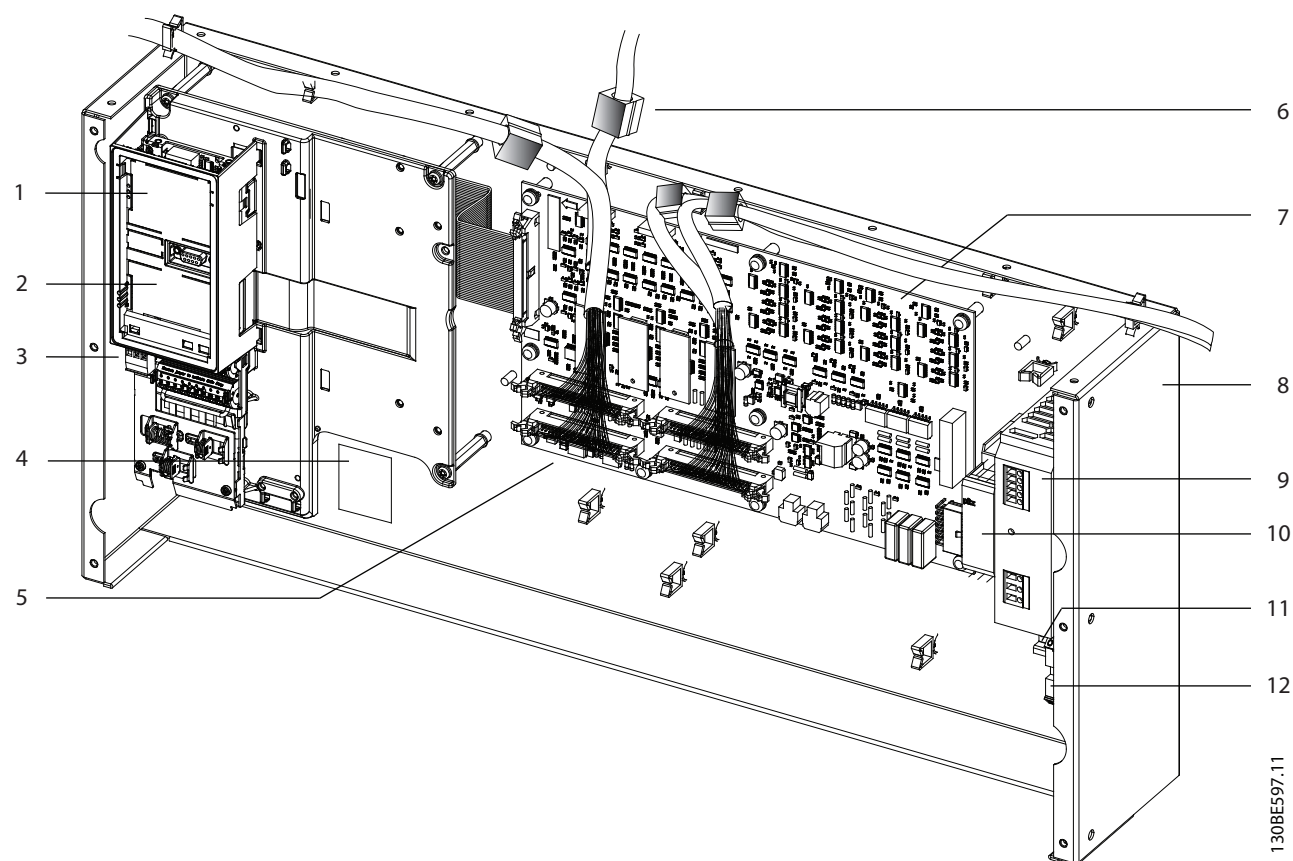

130BE597.11

1	LCP cradle	7	Multi-drive control interface card (MDCIC)
2	LCP control card (underneath cover)	8	Control shelf
3	Control terminal blocks	9	Power supply for Pilz relay (optional)
4	System identification label	10	Pilz relay (optional)
5	44-pin cables between MDCIC and drive modules	11	DIN rail
6	Ferrite core	12	Drive relay terminals

Illustration 3.5 View of the Control Shelf

3.6.5 Exploded View of Parallel Drive Module

VLT® Parallel Drive Modules are used in parallel drive systems, not as standalone modules. The parallel drive modules do not hold the control card and LCP, which are mounted on the control shelf. The modules connect to the control shelf via the cable connectors at the top of each module.

3

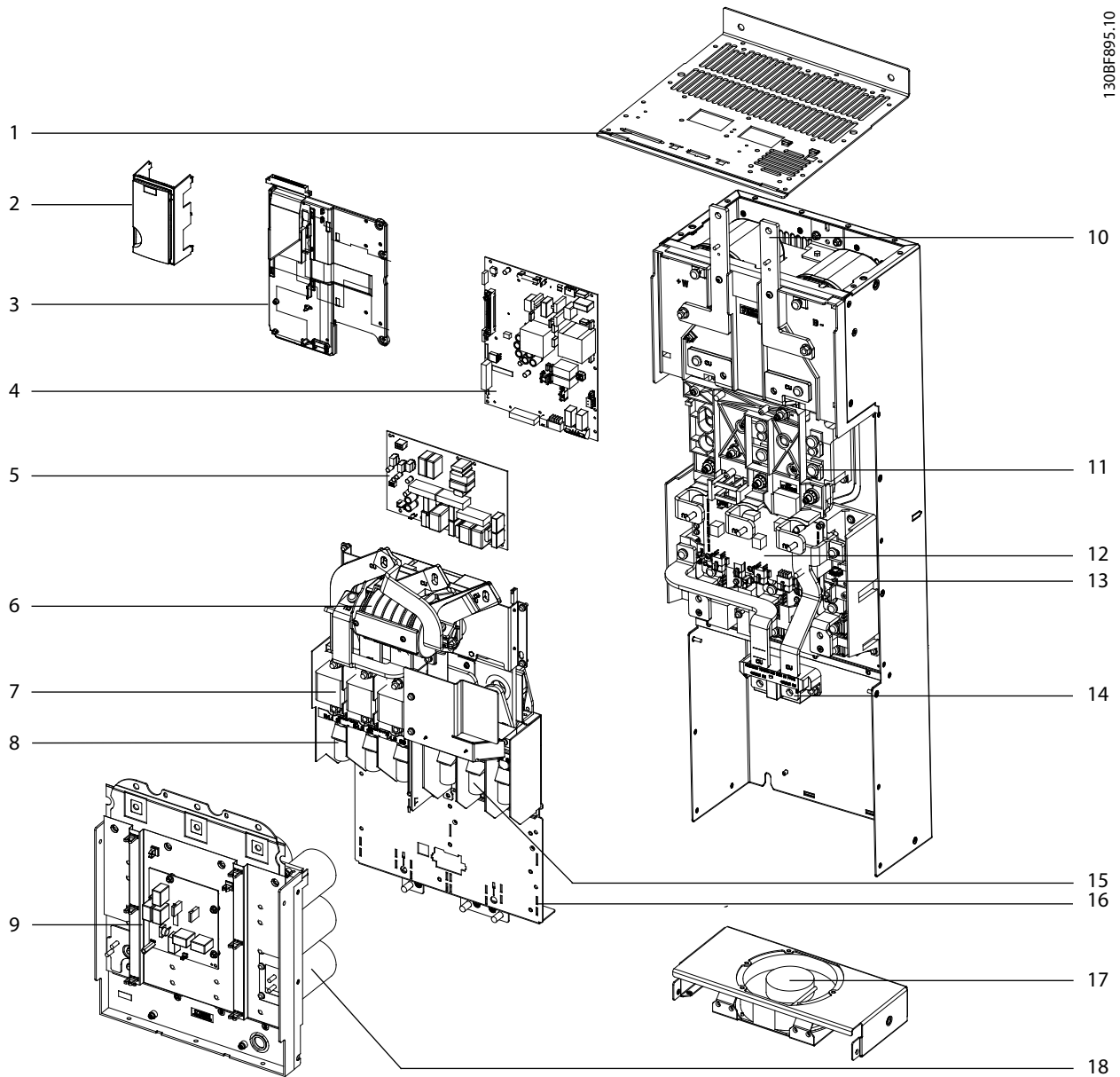

130BF895.10

1	MDCIC cable connector slot	7	AC fuse	13	IGBT modules
2	Blank cover plate (no LCP)	8	Mains input terminal	14	Brake terminals (optional)
3	Mounting plate (no control card)	9	Balance/high frequency card	15	Motor output terminal
4	Power card and mounting plate	10	Busbar/regeneration terminal	16	Power terminal mounting plate
5	Inrush card	11	SCR/diode modules	17	Heat sink fan
6	RFI filter (optional)	12	Gate drive card	18	Capacitor bank

Illustration 3.6 Exploded View of Parallel Drive Module

3.6.6 View of Parallel Drive Module

Each drive module has an IP00 protection rating. Either 2 or 4 modules can be connected in parallel to create a drive system.

3

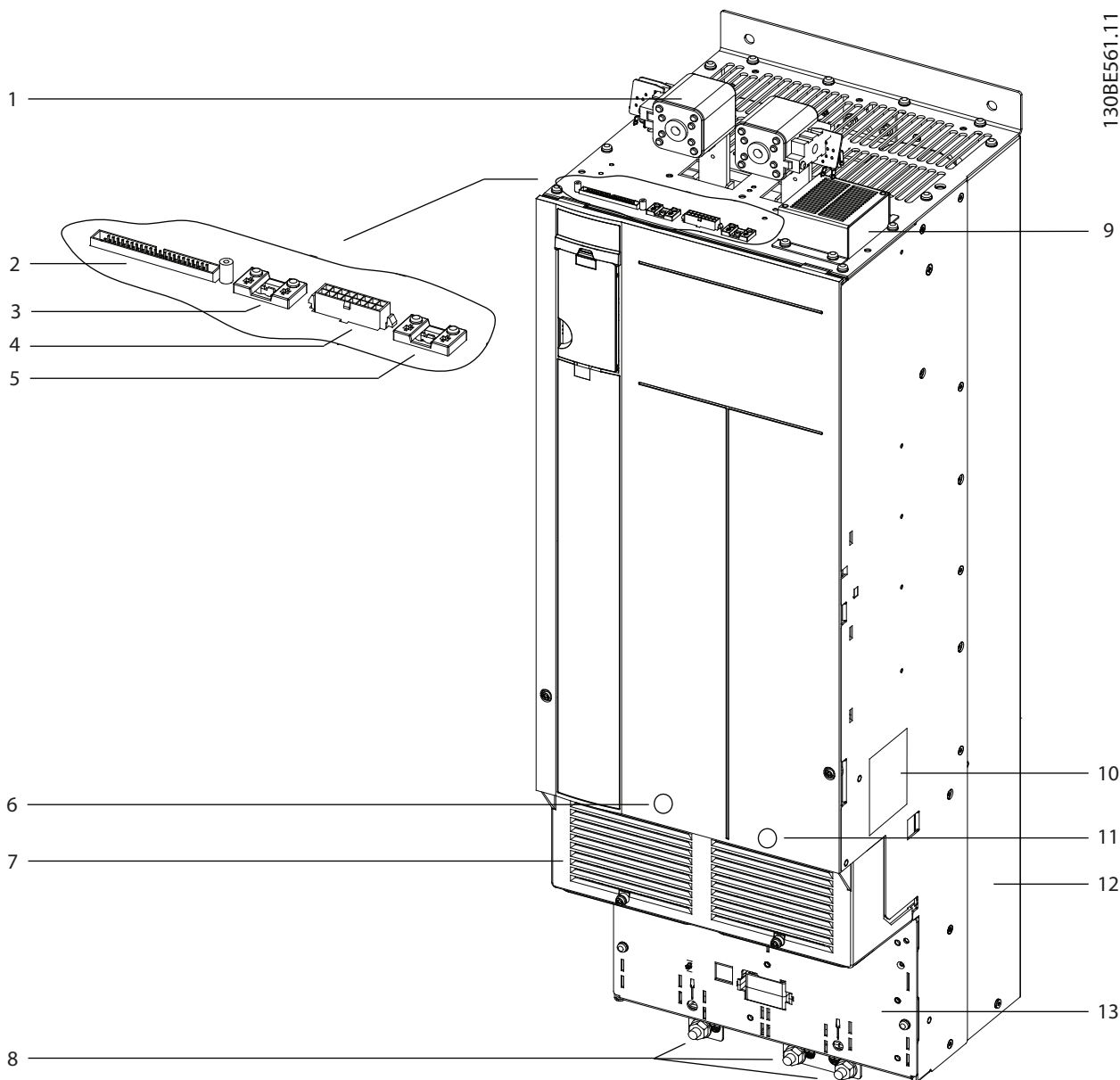

1	DC-link terminal and DC fuse	8	Ground terminals
2	MDCIC plug	9	Top fan
3	Microswitch to DC fuse connector	10	Drive module label
4	Relay 1 and 2 connector	11	Motor output terminals (inside the unit)
5	Brake fault jumper and connector	12	Heat sink and heat sink fan
6	Mains input terminals (inside the unit)	13	Ground plate
7	Terminal cover	-	-

Illustration 3.7 View of Parallel Drive Module

3.6.7 Exploded View of E-sized Unit

3

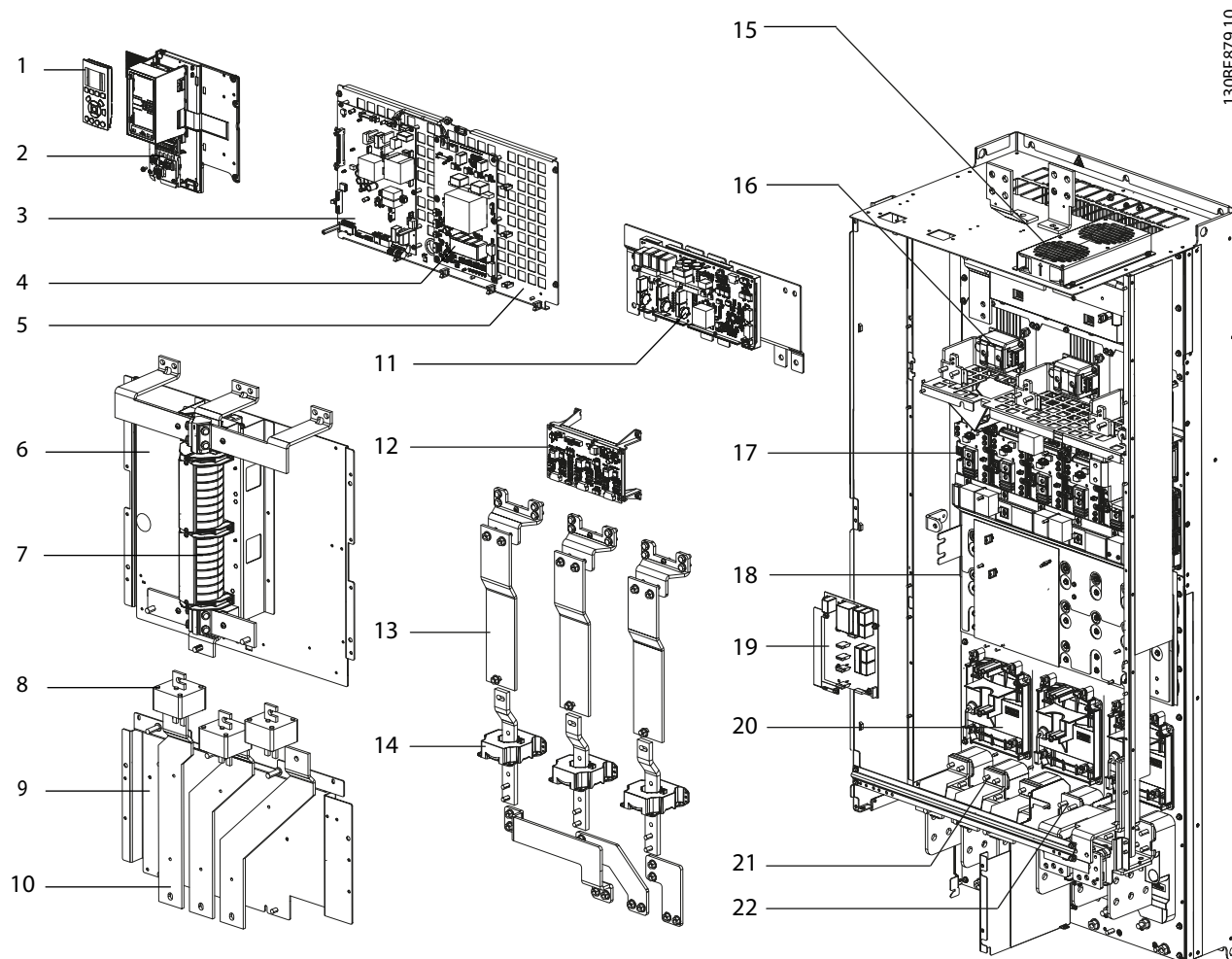

130BF879.10

1	LCP (Local control panel)	12	Gate drive card
2	Control card	13	Motor busbar assembly
3	Power card	14	Current sensors
4	Fan power card	15	Top fan
5	Power card mounting plate	16	SCR/diode modules
6	Upper input plate	17	IGBT modules
7	RFI filter (optional)	18	DC capacitor bank
8	AC fuses (optional)	19	Balance/high frequency card
9	Lower input plate	20	Heat sink fans
10	AC input busbars	21	Input terminals
11	Inrush card	22	Motor terminals

Illustration 3.8 Exploded View E3h Unit (E4h Unit is similar).

3.7 Product Options

Product options	Option location	
	Main enclosure	Extended options cabinet
RFI filter ¹⁾	X	
Mains fuses only ²⁾	X	
Contactor + fuses ¹⁾		X
Disconnect + fuses ¹⁾		X
Circuit breaker + fuses ¹⁾		X
Contactor + disconnect + fuses ¹⁾		X
Regeneration terminals ³⁾	X	
Load sharing terminals	X	
Brake chopper ⁴⁾	X	
Anti-condensation heater		X
Multiwire kit		X

Table 3.11 Options available for D1h–D8h Drives

1) Contactor, disconnect, or circuit breaker options always include fuses. These options are not applicable to parallel drive systems.

2) AC fuses are the default configuration for VLT® Parallel Drive Modules.

3) Regeneration terminals are standard in J8/J9 drives.

4) Brake option is not available in J8/J9 drives.

Product options	Option location
	Main enclosure
RFI filter	X
AC fuses	X
Disconnect + fuses ¹⁾	X
Regeneration terminals	X
Load sharing terminals	X
Brake	X

Table 3.12 Options available for E1h–E4h Drives

1) The disconnect option always includes fuses. Disconnect is not available in E3/E4 units.

4 Operator Interface and Drive Control

4.1 Introduction

Drives are designed with self-diagnostic circuitry to isolate fault conditions and show messages that simplify troubleshooting and service. The operating status of the drive is shown in real time. Virtually every command given to the drive results in some indication on the local control panel (LCP) display. Fault logs are maintained within the drive for fault history.

The drive monitors supply and output voltages along with the operational condition of the motor and load. When the drive issues a warning or alarm, the fault is not always within the drive itself. In fact, for most service calls, the fault condition exists outside of the drive. Most of the warnings and alarms that the drive shows are in response to faults outside of the drive. This service guide provides techniques and test procedures to help isolate a fault condition whether in the drive or elsewhere.

Familiarity with the information provided on the LCP display is important. More diagnostic data can be accessed easily through the LCP.

4.2 Local Control Panel

The local control panel (LCP) is the combined display and keypad on the front of the unit. See *Illustration 4.1*.

The LCP has several user functions:

- Starts, stops, and controls speed when in local control.
- Shows operational data, status, warnings, and alarms.
- Programs drive functions.
- Manually resets the drive after a fault when auto reset is inactive.

4.2.1 Layout

The LCP is activated when the drive receives power from 1 of the following:

- Mains voltage
- DC bus terminal
- 24 V DC external supply

The LCP is divided into the following functional groups:

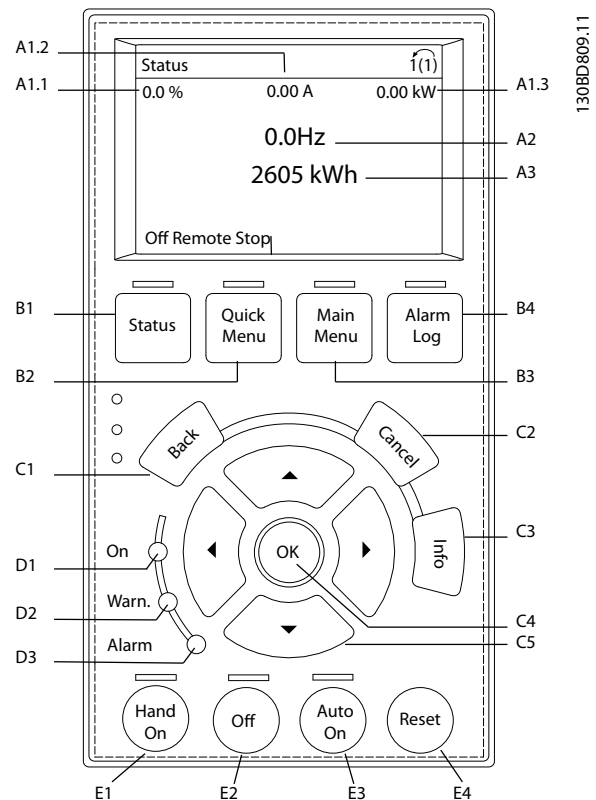

Illustration 4.1 Local Control Panel (LCP)

A. Display area

Each display readout has a parameter associated with it. Refer to *Illustration 4.1*. The information shown on the LCP can be customized for user application by selecting options in the Quick Menu *Q1 My Personal Menu*.

Callout	Parameter number	Default setting
A1.1	0-20	Refer to <i>Table 4.6 – Table 4.8</i>
A1.2	0-21	
A1.3	0-22	
A2	0-23	
A3	0-24	

Table 4.1 LCP Display Area

B. Menu keys

Menu keys are used to access the menu for setting up parameters, toggling through status display modes during normal operation, and viewing fault log data.

Callout	Key	Function
B1	Status	Shows operational information.
B2	Quick Menu	Allows access to parameters for initial set-up instructions. Also provides detailed application steps. Refer to <i>chapter 4.2.2.1 Quick Menu Mode</i> .
B3	Main Menu	Allows access to all parameters. Refer to <i>chapter 4.2.2.6 Main Menu Mode</i> .
B4	Alarm Log	Shows a list of current warnings and the last 10 alarms.

Table 4.2 LCP Menu Keys

C. Navigation keys

Navigation keys are used for programming functions and moving the display cursor. The navigation keys also provide speed control in local (hand) operation. Adjust display brightness by pressing [Status] and [▲]/[▼] keys.

Callout	Key	Function
C1	Back	Reverts to the previous step or list in the menu structure.
C2	Cancel	Cancels the last change or command as long as the display mode has not changed.
C3	Info	Shows a definition of the function being shown.
C4	OK	Accesses parameter groups or enables an option.
C5	▲ ▼ ◀ ▶	Moves between items in the menu.

Table 4.3 LCP Navigation Keys

D. Indicator lights

Indicator lights are used to identify the drive status and to provide a visual notification of warning or fault conditions.

Callout	Indicator	Indicator light	Function
D1	On	Green	Activates when the drive receives power from the mains voltage or a 24 V external supply.
D2	Warn.	Yellow	Activates when warning conditions are active. Text appears in the display area identifying the problem.
D3	Alarm	Red	Activates during a fault condition. Text appears in the display area identifying the problem.

Table 4.4 LCP Indicator Lights

E. Operation keys and reset

The operation keys are found toward the bottom of the local control panel.

Callout	Key	Function
E1	[Hand On]	Starts the drive in local control. An external stop signal by control input or serial communication overrides the local hand on.
E2	Off	Stops the motor but does not remove power to the drive.
E3	Auto On	Puts the system in remote operational mode so it can respond to an external start command by control terminals or serial communication.
E4	Reset	Resets the drive manually after a fault has been cleared.

Table 4.5 LCP Operation Keys and Reset

4.2.2 Menus

4.2.2.1 Quick Menu Mode

The LCP provides access to parameters via the Quick Menu. To list the quick menu options, press [Quick Menu].

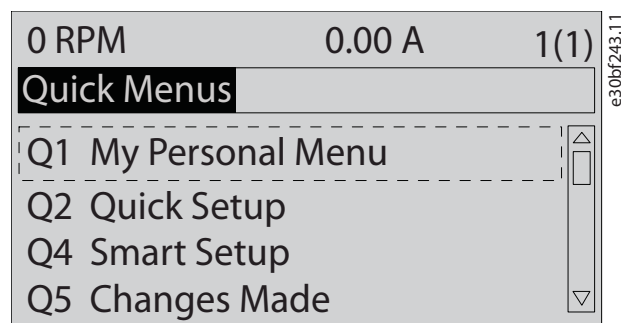

Illustration 4.2 Quick Menu View

4.2.2.2 Q1 My Personal Menu

My Personal Menu is used to define the LCP display (refer to *chapter 4.2.1 Layout*) and store pre-selected parameters. Store important set-up values by using up to 20 pre-programmed parameters. These parameters are selected in *parameter 0-25 My Personal Menu*.

Parameter	Default setting
Parameter 0-01 Language	English
Parameter 0-20 Display Line 1.1 Small	Reference %
Parameter 0-21 Display Line 1.2 Small	Motor current
Parameter 0-22 Display Line 1.3 Small	Power [kW]
Parameter 0-23 Display Line 2 Large	Frequency
Parameter 0-24 Display Line 3 Large	kWh counter
Parameter 15-51 Frequency Converter Serial Number	

Table 4.6 Q1 My Personal Menu Settings for VLT® HVAC Drive FC 102

Parameter	Default setting
Parameter 0-01 Language	English
Parameter 0-20 Display Line 1.1 Small	Reference [Unit]
Parameter 0-21 Display Line 1.2 Small	Analog input 53
Parameter 0-22 Display Line 1.3 Small	Motor current
Parameter 0-23 Display Line 2 Large	Frequency
Parameter 0-24 Display Line 3 Large	Feedback [Unit]
Parameter 15-51 Frequency Converter Serial Number	

Table 4.7 Q1 My Personal Menu Settings for VLT® AQUA Drive FC 202

Parameter	Default setting
Parameter 0-01 Language	English
Parameter 0-20 Display Line 1.1 Small	Speed [RPM]
Parameter 0-21 Display Line 1.2 Small	Motor current
Parameter 0-22 Display Line 1.3 Small	Power [kW]
Parameter 0-23 Display Line 2 Large	Frequency
Parameter 0-24 Display Line 3 Large	Reference %
Parameter 15-51 Frequency Converter Serial Number	

Table 4.8 Q1 My Personal Menu Settings for VLT® AutomationDrive FC 302

4.2.2.3 Q2 Quick Set-up

The parameters in *Q2 Quick Set-up* are the basic parameters that are always necessary for set-up. This menu provides the most efficient set-up for most applications. Perform the unit set-up in the order listed. Refer to the *programming guide* for the set-up steps.

4.2.2.4 Q5 Changes Made

Select *Q5 Changes Made* for information about:

- The 10 most recent changes.
- Changes made from default setting.

4.2.2.5 Q6 Loggings

Use *Q6 Loggings* for fault finding. To get information about the display line readout, select *Loggings*. The information is shown as graphs. Only show parameters selected in *parameter 0-20 Display Line 1.1 Small* to *parameter 0-24 Display Line 3 Large* can be viewed. It is possible to store up to 120 samples in the memory for later reference.

Q6 Loggings	
Parameter 0-20 Display Line 1.1 Small	Speed [RPM]
Parameter 0-21 Display Line 1.2 Small	Motor Current
Parameter 0-22 Display Line 1.3 Small	Power [kW]
Parameter 0-23 Display Line 2 Large	Frequency
Parameter 0-24 Display Line 3 Large	Reference %

Table 4.9 Loggings Parameter Examples

4.2.2.6 Main Menu Mode

The LCP provides access to the *Main Menu* mode. Select the *Main Menu* mode by pressing the [Main Menu] key. The resulting readout appears on the LCP display.

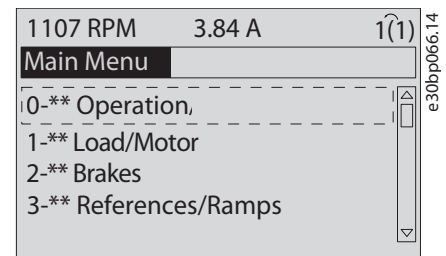

Illustration 4.3 Main Menu View

Lines 2 through 5 on the display show a list of parameter groups that can be selected via the [▲] and [▼] keys.

All parameters can be changed in the main menu. Option cards added to the unit enable extra parameters associated with the option device.

4.2.3 Parameter Settings

Establishing the correct programming for applications requires setting several parameter functions. Details for parameters are provided in the *programming guide*.

Parameter settings are stored internally in the drive, allowing the following advantages:

- Parameter settings can be uploaded into the LCP memory and stored as a back-up.
- Multiple units can be programmed quickly by connecting the LCP to the unit and downloading the stored parameter settings.
- Settings that are stored in the LCP are not changed when restoring factory default settings.

4.2.4 Uploading and Downloading Parameter Settings

The drive operates using parameters stored on the control card, which is located within the drive. The upload and download functions move the parameters between the control card and the LCP.

1. Press [Off].
2. Go to *parameter 0-50 LCP Copy* and press [OK].
3. Select 1 of the following:
 - 3a To upload data from the control card to the LCP, select [1] *All to LCP*.
 - 3b To download data from the LCP to the control card, select [2] *All from LCP*.
4. Press [OK]. A progress bar shows the uploading or downloading process.
5. Press [Hand On] or [Auto On].

4.2.5 Restoring Factory Default Settings

NOTICE

LOSS OF DATA

Loss of programming, motor data, localization, and monitoring records occurs when restoring default settings. To create a back-up, upload data to the LCP before initialization. Refer to *chapter 4.2.4 Uploading and Downloading Parameter Settings*.

Restore the default parameter settings by initializing the unit. Initialization is carried out through *parameter 14-22 Operation Mode* or manually.

Parameter 14-22 Operation Mode does not reset settings such as the following:

- Running hours
- Serial communication options
- Personal menu settings
- Fault log, alarm log, and other monitoring functions

Recommended initialization

1. Press [Main Menu] twice to access parameters.
2. Go to *parameter 14-22 Operation Mode* and press [OK].
3. Scroll to *Initialization* and press [OK].
4. Remove power to the unit and wait for the display to turn off.
5. Apply power to the unit. Default parameter settings are restored during start-up. Start-up takes slightly longer than normal.
6. After *alarm 80, Drive initialized to default value* appears, press [Reset].

Manual initialization

Manual initialization resets all factory settings except for the following:

- *Parameter 15-00 Operating hours*
- *Parameter 15-03 Power Up's*
- *Parameter 15-04 Over Temp's*
- *Parameter 15-05 Over Volt's*

To perform manual initialization:

1. Remove power to the unit and wait for the display to turn off.
2. Press and hold [Status], [Main Menu], and [OK] simultaneously while applying power (approximately 5 s or until a click sounds and the fan starts). Start-up takes slightly longer than normal.

4.3 Status Messages

When the drive is in status mode, status messages automatically appear in the bottom line of the LCP display (refer to *Illustration 4.4.*) Status messages are defined in *Table 4.10 – Table 4.12.*

4

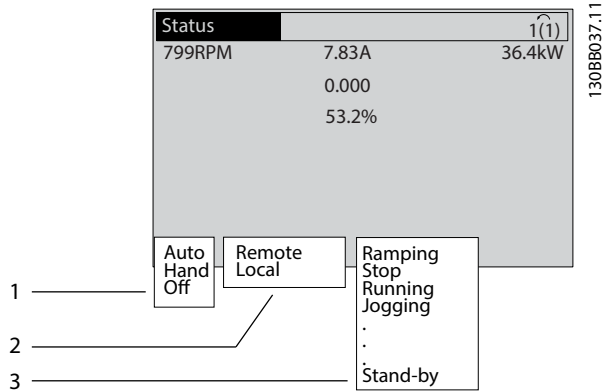

1	The first part of the status line indicates where the stop/start command originates. Refer to <i>Table 4.10.</i>
2	The second part of the status line indicates where the speed control originates. Refer to <i>Table 4.11.</i>
3	The last part of the status line gives the present drive status. The status shows the operational mode that the drive is in. Refer to <i>Table 4.12.</i>

Illustration 4.4 Status Display

NOTICE

AUTO/REMOTE MODE

In auto/remote mode, the drive requires external commands to execute functions.

4.4 Status Message Definitions

Table 4.10 – Table 4.12 define the listed status messages.

Off	The drive does not react to any control signal until [Auto On] or [Hand On] is pressed.
Auto	Start/stop commands are sent via the control terminals and/or serial communication.
Hand	The navigation keys on the LCP can be used to control the drive. Stop commands, reset, reversing, DC brake, and other signals applied to the control terminals can override local control.

Table 4.10 Operating Mode

Remote	The speed reference is given from <ul style="list-style-type: none"> External signals. Serial communication. Internal preset references.
Local	The drive uses reference values from the LCP.

Table 4.11 Reference Site

AC braking	AC braking was selected in <i>parameter 2-10 Brake Function</i> . The AC braking overmagnetizes the motor to achieve a controlled slow down.
AMA finish OK	Automatic motor adaptation (AMA) was carried out successfully.
AMA ready	AMA is ready to start. Press [Hand On].
AMA running	AMA process is in progress.
Braking	The brake chopper is in operation. The brake resistor absorbs the generative energy.
Braking max.	The brake chopper is in operation. The power limit for the brake resistor defined in <i>parameter 2-12 Brake Power Limit (kW)</i> has been reached.
Bus jog 1	PROFIdrive profile was selected in <i>parameter 8-10 Control Profile</i> . The Jog 1 function is activated via serial communication. The motor is running with <i>parameter 8-90 Bus Jog 1 Speed</i> .
Bus jog 2	PROFIdrive profile was selected in <i>parameter 8-10 Control Profile</i> . The Jog 2 function is activated via serial communication. The motor is running with <i>parameter 8-91 Bus Jog 2 Speed</i> .

Catch up	<p>The value set in <i>parameter 3-12 Catch up/slow Down Value</i> corrects the output frequency.</p> <ul style="list-style-type: none"> Catch up is selected as a function for a digital input (<i>parameter group 5-1* Digital Inputs</i>). The corresponding terminal is active. Catch up was activated via serial communication.
Coast	<ul style="list-style-type: none"> Coast inverse was selected as a function for a digital input (<i>parameter group 5-1* Digital Inputs</i>). The corresponding terminal is not connected. Coast activated by serial communication.
Control ready	<p>PROFIdrive profile was selected in <i>parameter 8-10 Control Profile</i>. The drive needs the first part (for example, 0x047E) of the 2-part start command via serial communication to allow starting. Using a terminal is not possible.</p>
Ctrl. ramp-down	<p>[1] <i>Ctrl. ramp-down</i> was selected in <i>parameter 14-10 Mains Failure</i>.</p> <ul style="list-style-type: none"> The mains voltage is below the value set in <i>parameter 14-11 Mains Fault Voltage Level</i> at mains fault. The drive ramps down the motor using a controlled ramp down.
Current high	<p>The drive output current is above the limit set in <i>parameter 4-51 Warning Current High</i>.</p>
Current low	<p>The drive output current is below the limit set in <i>parameter 4-50 Warning Current Low</i>.</p>
DC hold	<p>[1] <i>DC hold</i> is selected in <i>parameter 1-80 Function at Stop</i> and a stop command is active. The motor is held by a DC current set in <i>parameter 2-00 DC Hold/Preheat Current</i>.</p>
DC stop	<p>The motor is held with a DC current (<i>parameter 2-01 DC Brake Current</i>) for a specified time (<i>parameter 2-02 DC Braking Time</i>).</p> <ul style="list-style-type: none"> DC brake is activated in <i>parameter 2-03 DC Brake Cut In Speed [RPM]</i> and a stop command is active. DC brake (inverse) is selected as a function for a digital input (<i>parameter group 5-1* Digital Inputs</i>). The corresponding terminal is not active. The DC brake is activated via serial communication.

DC voltage U0	<p>In <i>parameter 1-01 Motor Control Principle</i> and in <i>parameter 1-80 Function at Stop, [4] DC Voltage U0</i> is selected. When a stop command (for example, Stop (inverse)) is activated, the voltage selected according to the <i>parameter 1-55 V/f Characteristic - V</i> is applied to the motor.</p>
Feedback high	<p>The sum of all active feedbacks is above the feedback limit set in <i>parameter 4-57 Warning Feedback High</i>.</p>
Feedback low	<p>The sum of all active feedbacks is below the feedback limit set in <i>parameter 4-56 Warning Feedback Low</i>.</p>
Flying start	<p>The drive is testing if the connected motor is running with a speed that is in the adjusted speed range. The process was started by connecting a digital input (<i>parameter group 5-1* Digital Inputs</i>) programmed as coast inverse or by connecting to the mains.</p>
Freeze output	<p>The remote reference is active, which holds the present speed.</p> <ul style="list-style-type: none"> Freeze output was selected as a function for a digital input (<i>parameter group 5-1* Digital Inputs</i>). The corresponding terminal is active. Speed control is possible only via the terminal functions speed up and speed down. Hold ramp is activated via serial communication.
Freeze output request	<p>A freeze output command has been given, but the motor remains stopped until a run permissive signal is received.</p>
Freeze ref.	<p>Freeze reference was selected as a function for a digital input (<i>parameter group 5-1* Digital Inputs</i>). The corresponding terminal is active. The drive saves the actual reference. Changing the reference is now only possible via terminal functions speed up and speed down.</p>
Jog request	<p>A jog command has been given, but the motor is stopped until a run permissive signal is received via a digital input.</p>
Jogging	<p>The motor runs as programmed in <i>parameter 3-19 Jog Speed [RPM]</i>.</p> <ul style="list-style-type: none"> Jog was selected as function for a digital input (<i>parameter group 5-1* Digital Inputs</i>). The corresponding terminal (for example, terminal 29) is active. The jog function is activated via the serial communication. The jog function was selected as a reaction for a monitoring function (for example, No signal). The monitoring function is active.

Kinetic back-up	In <i>parameter 14-10 Mains Failure</i> , a function was set as [4] <i>kinetic back-up</i> . The mains voltage is below the value set in <i>parameter 14-11 Mains Fault Voltage Level</i> . The drive is running the motor momentarily with kinetic energy from the inertia of the load.
Motor check	In <i>parameter 1-80 Function at Stop</i> , [2] <i>Motor Check</i> was selected. A stop command is active. To ensure that a motor is connected to the drive, a permanent test current is applied to the motor. Only available in VLT® HVAC Drive FC 102 and VLT® AQUA Drive FC 202.
Off1	[1] <i>PROFdrive profile</i> was selected in <i>parameter 8-10 Control Profile</i> . The Off1 function is activated via serial communication. The motor is stopped via the ramp.
Off2	[1] <i>PROFdrive profile</i> was selected in <i>parameter 8-10 Control Profile</i> . The Off2 function is activated via serial communication. The output of the drive is disabled immediately and the motor coasts.
Off3	[1] <i>PROFdrive profile</i> was selected in <i>parameter 8-10 Control Profile</i> . The Off3 function is activated via serial communication. The motor is stopped via the ramp.
OVC control	[2] <i>Enabled</i> was activated in <i>parameter 2-17 Over-voltage Control</i> . The connected motor supplies the drive with generative energy. The overvoltage control adjusts the V/Hz ratio to run the motor in controlled mode, and to prevent the drive from tripping.
Power unit off	(For drives with a 24 V external supply installed only.) Mains supply to the drive is removed, but the control card is supplied by the external 24 V.
Pre-magnetize	Premagnetization is selected in <i>parameter 1-80 Function at Stop</i> . A stop command (for example, stop inverse) is activated. A suitable constant magnetizing current is applied to the motor.
Protection md	Protection mode is active. The unit has detected a critical status (an overcurrent or overvoltage). <ul style="list-style-type: none"> To avoid tripping, the switching frequency is reduced to 1500 kHz if <i>parameter 14-55 Output Filter</i> is set to [2] <i>Sine-Wave Filter Fixed</i>. Otherwise, the switching frequency is reduced to 1000 Hz. If possible, protection mode ends after approximately 10 s. Protection mode can be restricted in <i>parameter 14-26 Trip Delay at Inverter Fault</i>.

QStop	The motor decelerates using <i>parameter 3-81 Quick Stop Ramp Time</i> . <ul style="list-style-type: none"> [4] <i>Quick stop inverse</i> was selected as a function for a digital input (<i>parameter group 5-1* Digital Inputs</i>). The corresponding terminal is not active. The quick stop function was activated via serial communication.
Ramping	The motor accelerates/decelerates using the active ramp up/down. The reference, a limit value, or a standstill is not yet reached.
Ref. high	The sum of all active references is above the reference limit set in <i>parameter 4-55 Warning Reference High</i> .
Ref. low	The sum of all active references is below the reference limit set in <i>parameter 4-54 Warning Reference Low</i> .
Run on ref.	The drive is running in the reference range. The feedback value matches the setpoint value.
Run request	A start command has been given, but the motor is stopped until a run permissive signal is received via digital input. Only available in VLT® HVAC Drive FC 102 and VLT® AQUA Drive FC 202.
Running	The drive propels the motor, the ramping phase is done, and the motor revolutions are outside the on-reference range. Occurs when 1 of the motor speed limits (<i>parameters 4-11 to 4-14</i>) is set, but the maximum reference is outside this range.
Sleep boost	The boost function in <i>parameter 22-45 Setpoint Boost</i> is enabled. This function is only possible in closed-loop operation. Only available in VLT® HVAC Drive FC 102 and VLT® AQUA Drive FC 202.
Sleep mode	The energy saving function is enabled, which means the motor has now stopped, but restarts automatically when required. Only available in VLT® HVAC Drive FC 102 and VLT® AQUA Drive FC 202.
Speed down	The value set in <i>parameter 3-12 Catch up/slow Down Value</i> is used to correct the output frequency. <ul style="list-style-type: none"> Speed down was selected as a function for a digital input (<i>parameter group 5-1* Digital Inputs</i>). The corresponding terminal is active. Speed down was activated via serial communication.
Speed high	Motor speed is above the value set in <i>parameter 4-53 Warning Speed High</i> .
Speed low	Motor speed is below the value set in <i>parameter 4-52 Warning Speed Low</i> .

Standby	In auto-on mode, the drive starts the motor with a start signal from a digital input or serial communication.
Start delay	In <i>parameter 1-71 Start Delay</i> , a delay starting time was set. A start command is activated and the motor starts after the start delay time expires.
Start fwd/rev	[8] <i>Start</i> and 11 [<i>Start reversing</i>] were selected as functions for 2 different digital inputs (<i>parameter group 5-1* Digital Inputs</i>). The motor starts in forward or reverse depending on which corresponding terminal is activated.
Start inhibit	PROFdrive profile was selected in <i>parameter 8-10 Control Profile</i> . The start inhibition is active. The drive needs the first part (for example, 0x047E) of the 2-part start command via serial communication to allow starting. Refer to the <i>Control ready</i> function in this table.
Stop	The drive receives a stop command from 1 on the following: <ul style="list-style-type: none"> • LCP • Digital input • Serial communication
Trip	An alarm occurs and the motor stops. Once the cause of the alarm is cleared, reset the drive manually by <ul style="list-style-type: none"> • Pressing [Reset]. • Remotely by control terminals. • Via serial communication.
Trip lock	An alarm occurs and the motor stops. Once the cause of the alarm is cleared, cycle power to the drive. Reset the drive manually by <ul style="list-style-type: none"> • Pressing [Reset]. • Remotely by control terminals. • Via serial communication.
Unit/drive not ready	[1] <i>PROFdrive profile</i> was selected in <i>parameter 8-10 Control Profile</i> . A control word is sent to the drive via serial communication with Off 1, Off 2, and Off 3 active. Start inhibit is active. To enable start, refer to <i>Start inhibit</i> function in this table.

Table 4.12 Operation Status

NOTICE

AUTO/REMOTE MODE

In auto/remote mode, the drive requires external commands to execute functions.

4.5 Service Functions

Service information for the drive is listed on display lines 3 and 4. Service information includes:

- Operating hours.
- Power ups.
- Trips.
- Fault logs of status values during the 20 most recent events that stopped the drive.
- Drive nameplate data.

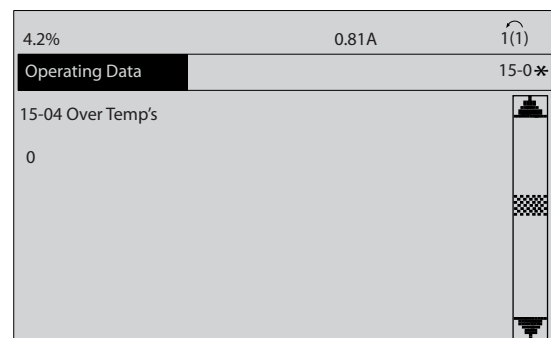

Illustration 4.5 Example of Service Information

See the *programming guide* for information on accessing and viewing parameters, and for service information available in *parameter group 15-** Drive Information*.

4.6 Drive Inputs and Outputs

The drive operates by receiving control input signals. The drive can also output status data or control auxiliary devices. Control input is connected to the drive in 3 possible ways. One way to control the drive is through the LCP on the front of the drive when operating in hand-on mode. These inputs include start, stop, reset, and speed reference.

Another control source is through serial communication from a fieldbus. A serial communication protocol supplies commands and references to the drive, can program the drive, and reads status data from the drive. The fieldbus connects to the drive through the RS485 serial port or through a communication option card.

The 3rd way is through signal wiring connected to the drive control terminals. Refer to *Illustration 4.6*. The drive control terminals are located below the drive LCP. Improperly connected control wiring can be the cause of a motor not operating or the drive not responding to a remote input.

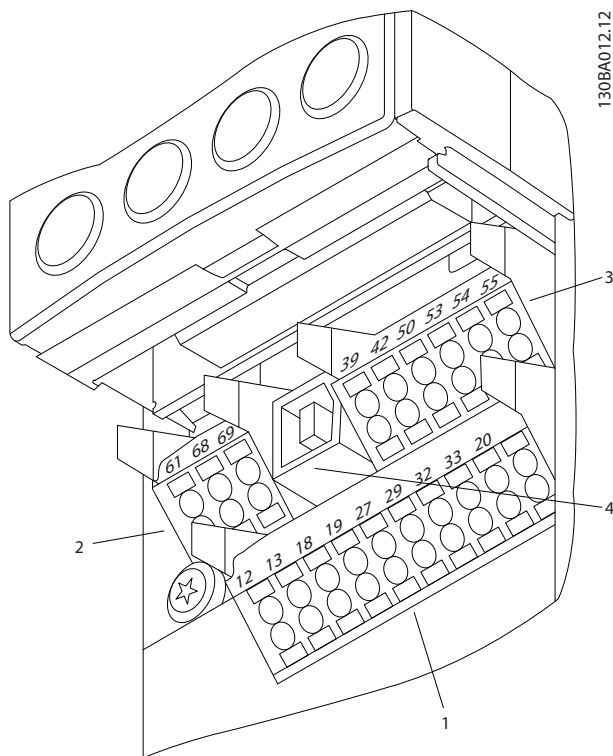

1	Digital I/O terminals
2	RS485 (EIA-485) terminal
3	Analog I/O terminals
4	USB connector

Illustration 4.6 Control Terminals

4.6.1 Input Signals

The drive can receive 2 types of remote input signals: digital or analog. Digital inputs are wired to terminals 18, 19, 20 (common), 27, 29, 32, and 33. Analog inputs are wired to terminals 53 or 54 and 55 (common). Underneath the LCP is a switch used for setting the analog terminal functions. Some options include more terminals for input signals.

Analog signals can be either voltage (0–10 V DC) or current (0–20 mA or 4–20 mA). Analog signals can be varied like dialing a rheostat up and down. The drive can be programmed to increase or decrease output in relation to the amount of current or voltage. For example, a sensor or external controller can supply a variable current or voltage. The drive output, in turn, regulates the speed of the motor connected to the drive in response to the analog signal.

Digital signals are a simple binary 0 or 1 that act as a switch. A 0–24 V DC signal controls the digital signals. A voltage signal lower than 5 V DC is a logic 0 (open). A voltage higher than 10 V DC is a logic 1 (closed). Digital inputs to the drive are switched commands such as start, stop, reverse, coast, reset.

NOTICE

SERIAL COMMUNICATION FORMAT

Do not confuse these digital inputs with serial communication formats where digital bytes are grouped into communication words and protocols.

The RS485 serial communication connector is wired to terminals (+) 68 and (-) 69. Terminal 61 is common and is sometimes used for terminating shields when the control cable is run between multiple drives, not other devices. Refer to *chapter 4.9 Shielded Cable Grounding* for correct methods for terminating a shielded control cable.

4.6.2 Output Signals

The drive also produces output signals that are carried through either the RS485 fieldbus or terminal 42. Output terminal 42 operates in the same manner as the inputs. The terminal can be programmed for either a variable analog signal in mA or a digital signal (0 or 1) in 24 V DC. In addition, a pulse reference can be provided on terminals 27 and 29. Output analog signals generally indicate the drive frequency, current, torque, and so on, to an external controller or system. Digital outputs can be control signals used to open or close a damper, for example, or to send a start or stop command to auxiliary equipment. Some options include more terminals for output signals.

More terminals are Form C relay outputs on terminals 01, 02, and 03, and terminals 04, 05, and 06.

4.6.3 Control Supply

Terminals 12 and 13 provide 24 V DC low voltage power to the digital input terminals (18–33). Those terminals must be supplied with power from either terminal 12 or 13, or from a customer-supplied external 24 V DC power source. Improperly connected control wiring is a common service issue for a motor not operating or a drive not responding to a remote input.

4.7 Control Terminals

Control terminals must be programmed. Each terminal has specific functions it performs and a numbered parameter associated with it. Refer to *Table 4.13*. The setting selected in the parameter enables the function of the terminal. It is important to confirm that the control terminal is programmed for the correct function.

In addition, the input terminal must be receiving a signal. Confirm that the control and power sources are wired to the terminal. Then check the signal.

Signals can be checked in 2 ways. To select digital input for display, press the [Status] key as discussed previously, or use a voltmeter to check for voltage at the control terminal. Refer to *chapter 8.5.14 Input Terminal Signal Tests*.

For proper operation of the drive, the drive input control terminals must be:

- Wired properly.
- Powered.
- Programmed correctly for the intended function.
- Receiving a signal.

4.8 Control Terminal Functions

Table 4.13 describes the functions of the control terminals. Many of these terminals have multiple functions determined by parameter settings. Some options provide more terminals.

Terminal	Function
01, 02, 03 and 04, 05, 06	Two Form C output relays. Maximum 240 V AC, 2 A. Minimum 24 V DC, 10 mA, or 24 V AC, 100 mA. Can be used for indicating status and warnings. Found on the power card.
12, 13	24 V DC supply to digital inputs and external transducers. The maximum output current is 200 mA.
18, 19, 27, 29, 32, 33	Digital inputs for controlling the drive. $R = 2 \text{ k}\Omega$. Less than 5 V = logic 0 (open). Greater than 10 V = logic 1 (closed). Terminals 27 and 29 are programmable as digital/pulse outputs.
20	Common for digital inputs.
37	0–24 V DC input for Safe Torque Off (some units).
39	Common for analog and digital outputs.
42	Analog and digital outputs for indicating values such as frequency, reference, current, and torque. The analog signal is 0/4 to 20 mA at a maximum of 500 Ω . The digital signal is 24 V DC at a minimum of 500 Ω .
50	10 V DC, 15 mA maximum analog supply voltage for potentiometer or thermistor.
53, 54	Selectable for 0–10 V DC voltage input, $R = 10 \text{ k}\Omega$, or analog signals 0/4 to 20 mA at a maximum of 200 Ω . Used for reference or feedback signals. A thermistor can be connected here.
55	Common for terminals 53 and 54.
61	RS485 common.
68, 69	RS485 interface and serial communication.

Table 4.13 Control Terminals and Functions

Terminal	18	19	27	29	32	33	37	53	54	42	1–3	4–6
Parameter	5-10	5-11	5-12	5-13	5-14	5-15	5-19	6-1*	6-2*	6-5*	5-4*	5-4*

Table 4.14 Control Terminals and Associated Parameters

4.9 Shielded Cable Grounding

Connect the shielded control cables with cable clamps at both ends to the metal cabinet of the drive. *Table 4.15* shows ground cabling for optimal results.

	<p>Correct grounding Fit control cables and cables for serial communication with cable clamps at both ends to ensure the best possible electrical connection.</p>
	<p>Incorrect grounding Do not use twisted cable ends (pigtailed) since it increases shield impedance at high frequencies.</p>
	<p>Ground potential protection When the ground potential between the drive and the PLC or other interface device is different, electrical noise occurs that can disturb the entire system. Fitting an equalizing cable next to the control cable resolves this issue. Minimum cable cross-section is 8.36 mm² (8 AWG).</p>
	<p>50/60 Hz ground loops When using long control cables, 50/60 Hz ground loops can occur, disturbing the entire system. Connecting 1 end of the shield with a 100 nF capacitor and keeping the lead short resolves this issue.</p>
	<p>Serial communication control cables Low-frequency noise currents between drives can be eliminated by connecting 1 end of the shielded cable to drive terminal 61. This terminal connects to ground through an internal RC link. Reduce the differential mode interference between conductors by using twisted-pair cables.</p>

Table 4.15 Shielded Cable Grounding

5 Internal Drive Operation

5.1 Introduction

This section is intended to provide an operational overview of the main assemblies and circuitry of a drive. With this information, a repair technician can better understand the operation of the drive and the troubleshooting process.

5.2 Description of Operation

A drive is an electronic controller that supplies a regulated amount of AC power to a 3-phase asynchronous motor. By supplying variable frequency and voltage to the motor, the drive controls the motor speed. It can also maintain a constant speed as the load on the motor changes. The drive can also stop and start a motor without the mechanical stress associated with a line start.

In its basic form, the drive can be divided into the following 4 main areas:

- Rectifier
- DC link (DC bus)
- Inverter
- Control

See *Illustration 5.1* for details.

Within those areas, components are grouped into 3 sections:

- Control logic section
- Logic-to-power interface
- Power section

These areas and components are covered in greater detail in *chapter 5.3 Sequence of Operation*.

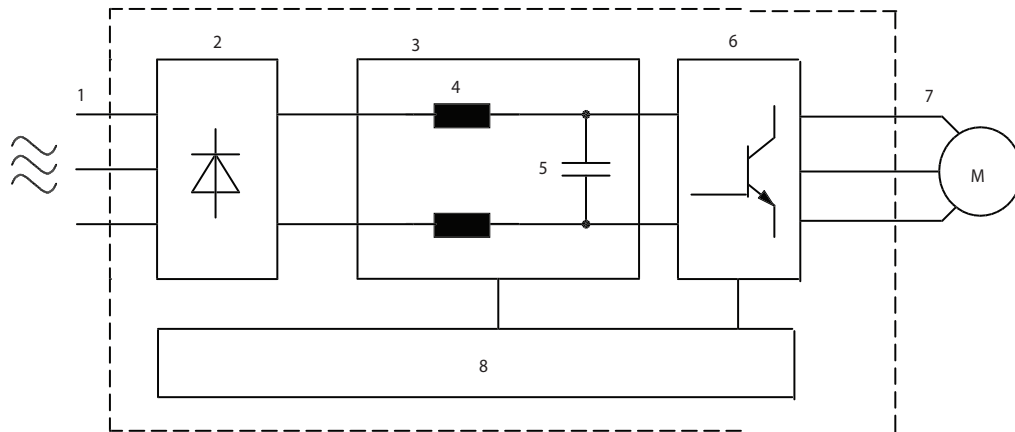

130BE894.11

5

Area	Title	Functions
1	Mains input	Provides 3-phase AC mains power input to the drive module.
2	Input rectifier section	Converts mains input AC voltage into DC voltage.
3	Intermediate DC bus section	Acts as a filter and stores energy in the form of DC voltage.
4	DC reactors	<ul style="list-style-type: none"> Filter the DC-link voltage. Reduce RMS current. Raise the power factor reflected back to the line. Reduce harmonics on the AC input.
5	Capacitor bank	Stores the DC power and provides ride-through protection for short power losses.
6	Inverter section	Converts the DC voltage into a variable, controlled PWM AC output voltage to the motor.
7	Motor output	Sends output to the motor being controlled.
8	Control	<ul style="list-style-type: none"> Monitors input and motor current to provide efficient operation and control. Monitors the user interface and performs external commands. Can provide status output and control. Includes the power card, fan power card (in E-sized drives only), and inrush card. In a parallel drive system, a ribbon cable links the power card to the MDCIC on the control shelf. The MDCIC provides supervision over the drive modules in the system.

Illustration 5.1 Drive Module Basic Block Diagram

5.2.1 Logic Section

Microprocessor

The control card contains most of the logic section (see *Illustration 5.2*). The primary logic element of the control card is a microprocessor, which supervises and controls all functions of operation of the drive. In addition, separate PROMs contain the parameters to provide programmable options. These parameters are programmed to enable the drive to meet specific application requirements. This data is then stored in an EEPROM which provides security during power-down and allows for changing the operational characteristics of the drive.

PWM waveforms

A custom-integrated circuit generates a pulse width modulation (PWM) waveform which is then sent to the interface circuitry on the power card.

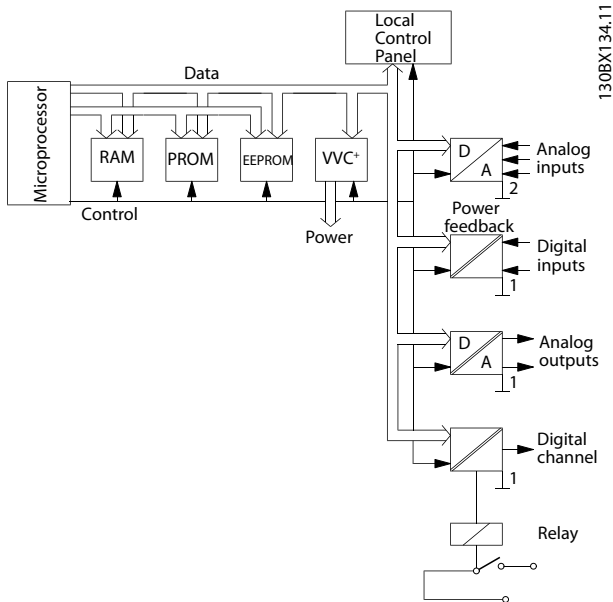

Illustration 5.2 Logic Section

The PWM waveform is created using an improved control scheme called VVC+, a further development of the earlier VVC (voltage vector control) system. VVC+ provides a variable frequency and voltage to the motor which matches the requirements of the motor.

Local control panel (LCP)

Another part of the logic section is the local control panel (LCP). The LCP is a removable keypad/display mounted on the front of the drive. The LCP provides the interface between the internal digital logic and the operator.

All the programmable parameter settings can be uploaded into the EEPROM of the LCP. This function is useful for maintaining a back-up drive profile and parameter set. It can also be used, through its download function, in programming other drives or to restore a program to a repaired unit. The LCP is removable during operation to

prevent undesired program changes. With the addition of a remote mounting kit, the LCP can be mounted in a remote location of up to 3 m (10 ft) away.

Control terminals

Control terminals, with programmable functions, are provided for input commands such as run, stop, forward, reverse, and speed reference. Extra output terminals are provided to supply signals to run peripheral devices or for monitoring and reporting status.

The control card logic can communicate via serial link with outside devices such as personal computers or programmable logic controllers (PLC).

The control card also provides 2 voltage supplies for use from the control terminals. The 24 V DC is used for switching functions such as start, stop, and forward/reverse. The 24 V DC supply can supply 200 mA of power, part of which can be used to power external encoders or other devices. A 10 V DC supply on terminal 50 is rated at 17 mA is also available for use with speed reference circuitry.

The analog and digital output signals are powered through an internal drive supply.

Two relays for monitoring the status of the drive are on the power card. They are programmable through *parameter group 5-4* Relays*. The relays have different ratings. See the corresponding *operating guide* or *design guide* for more information on ratings.

The control card logic circuitry allows for the addition of option modules for synchronizing the following types of software:

- Control
- Serial communications
- Extra relays
- Cascade pump controller
- Custom operating

5.2.2 Logic-to-power Interface

The logic-to-power interface isolates the high voltage components of the power section from the low voltage signals of the logic section. The interface section consists of the power card and gate drive card.

Control card

The control card handles much of the fault processing for output short circuit and ground fault conditions. The power card provides conditioning of these signals. The control card also handles scaling of current and voltage feedback.

Power card

The power card contains a switch mode power supply (SMPS), which provides the unit with 24 V DC, (+) 18 V DC, (-) 18 V DC, and 5 V DC operating voltage. The SMPS

powers the logic and interface circuitry. The SMPS is supplied by the DC bus voltage. The drives can be purchased with an optional secondary SMPS, which is powered from a customer supplied 24 V DC source. This secondary SMPS provides power to the logic circuitry with mains input disconnected. It can keep units with communication options live on a network when the drive is not powered from the mains.

The power card also supplies circuitry for controlling the speed of the cooling fans.

Gate drive card

The gate drive signals from the control card to the output transistors (IGBTs) are isolated and buffered on the gate drive card. In units that have the dynamic brake option, the driver circuits for the brake transistors are also found on this card.

5.2.3 Power Section

The high voltage power section consists of the following components:

- AC input and motor output terminals
- AC and DC busbars
- Fuses
- Wiring harness
- Circuitry
 - Soft charge and SCR/diode modules in the rectifier
 - DC bus filter circuitry containing the DC coils (intermediate or DC bus circuit)

- Output IGBT modules that make up the inverter section.

- Optional components

The inrush circuit controls the firing of the SCRs in the rectifier. When power is applied, the SCRs limit the charging rate of the DC capacitors. Once the capacitors are charged, the inrush circuit sequences the firing of the SCRs to maintain the proper charge on the DC capacitors. The DC bus circuitry regulates the pulsating DC voltage created by the input AC supply.

The DC coil is a single unit with 2 coils wound on a common core. One coil resides in the positive side of the DC bus and the other in the negative. The coil aids in the reduction of mains harmonics.

The DC bus capacitors are arranged into a capacitor bank along with bleeder and balancing circuitry.

The inverter section is made up of insulated-gate bipolar transistors, commonly referred to as IGBTs or switches. In D-sized drives, there are 3 IGBT modules. In E-sized drives, there are 6 IGBT modules. Each IGBT module contains multiple IGBTs.

A Hall effect type current sensor is used on each phase of the output to measure motor current. With Hall sensors, the drive can monitor:

- Average current.
- Peak current.
- Ground leakage current.

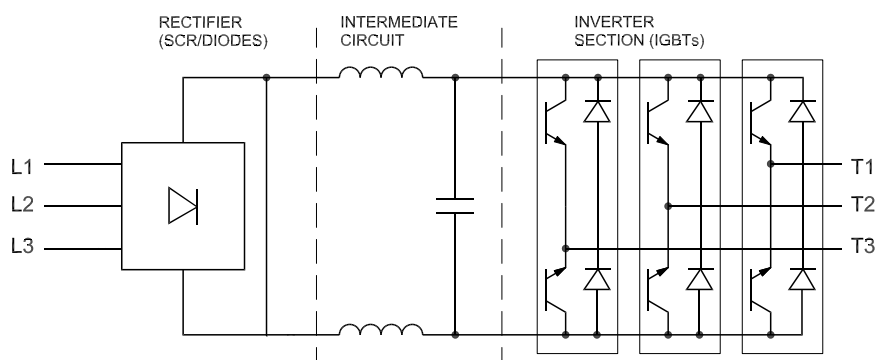

Illustration 5.3 Typical Power Section of an Individual Drive

5

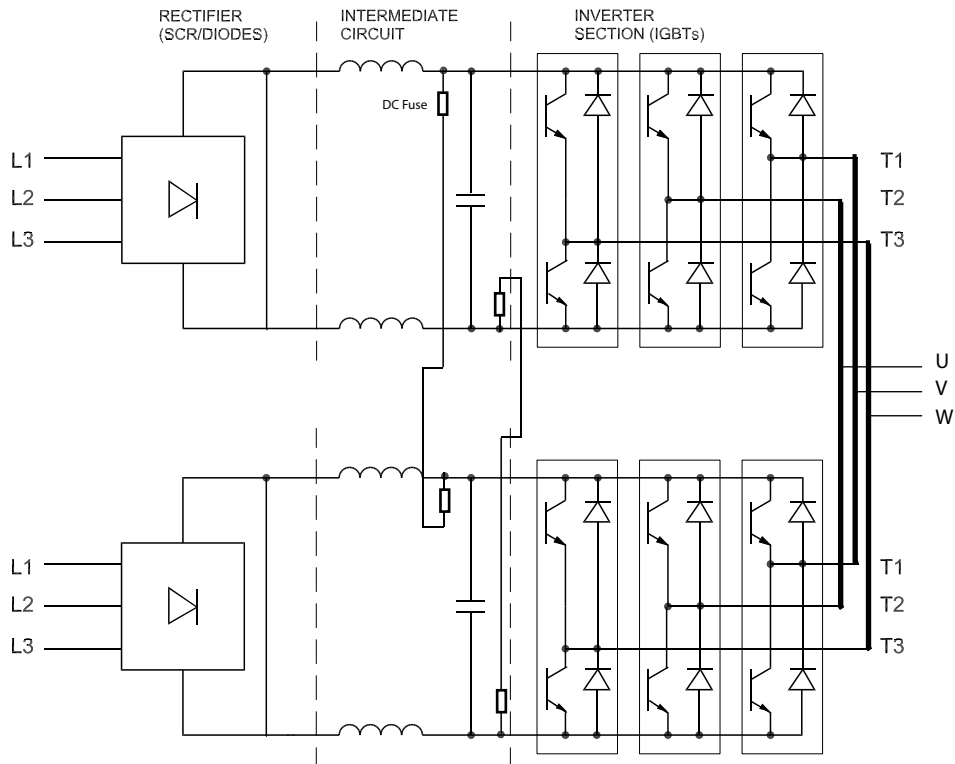

Illustration 5.4 Typical Power Section of a 2-module Parallel System

5.3 Sequence of Operation

5.3.1 Rectifier Section

When power is first applied to the drive, it enters through the input terminals (L1, L2, and L3). Then, power moves to the disconnect and/or RFI filter option, depending on the configuration. If equipped with optional fuses, these fuses limit damage caused by a short circuit in the power section. The input power is also connected to the inrush circuit. This circuit supplies gate signals to the SCRs, with a high firing angle (near 180°) at first. The firing angle decreases with every successive AC cycle until it reaches 0°. This process increases the DC voltage slowly over a period of several line cycles, thus greatly reducing the current for charging the DC capacitors.

NOTICE

In parallel drive systems, the input power is applied to each module.

The low voltage supplies are activated when the DC bus reaches approximately 50 V DC less than the alarm voltage

low for the DC bus. See *chapter 14 Product Specifications*. After a short delay, an inrush enable signal is sent from the control card to the inrush card SCR gating circuit. The SCRs are automatically gated when forward biased, acting similar to an uncontrolled rectifier as a result.

When the DC bus capacitors are fully charged, the voltage on the DC bus equals the peak voltage of the input AC line. Theoretically, this figure can be calculated by multiplying the AC line value by 1.414 ($V_{AC} \times 1.414$). However, since AC ripple voltage is present on the DC bus, the actual DC value is closer to $V_{AC} \times 1.38$ under unloaded conditions. It can drop to $V_{AC} \times 1.32$ while running under load. For example, a drive connected to a nominal 460 V line, while sitting idle, the DC bus voltage is approximately 635 V DC (460×1.38).

As long as power is applied to the drive, this voltage is present in the DC-link and inverter circuits. It is also fed to the switch mode power supply on the power card and is used for generating all other low voltage supplies.

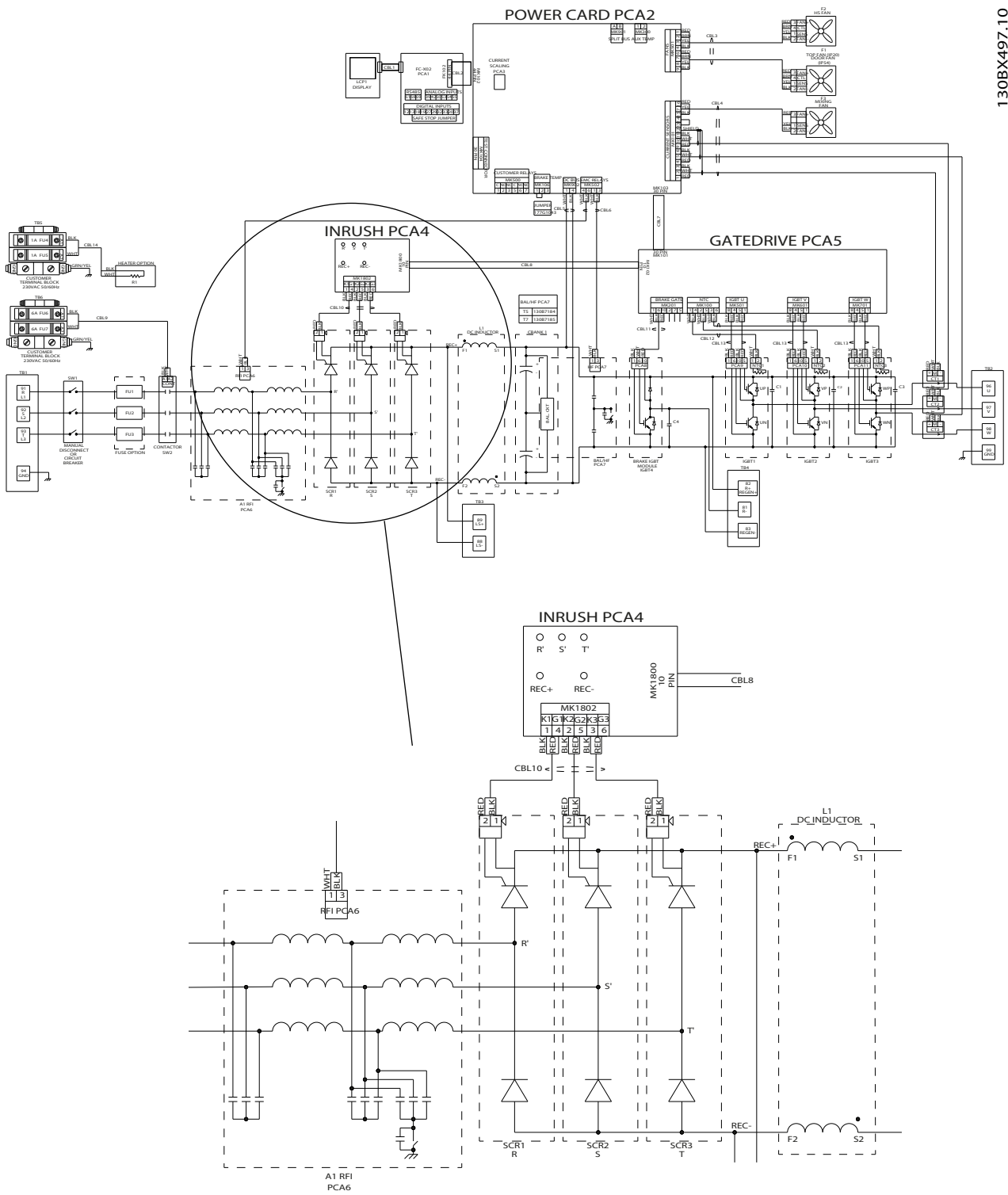

Illustration 5.5 Rectifier Circuit in D-sized Drives

5

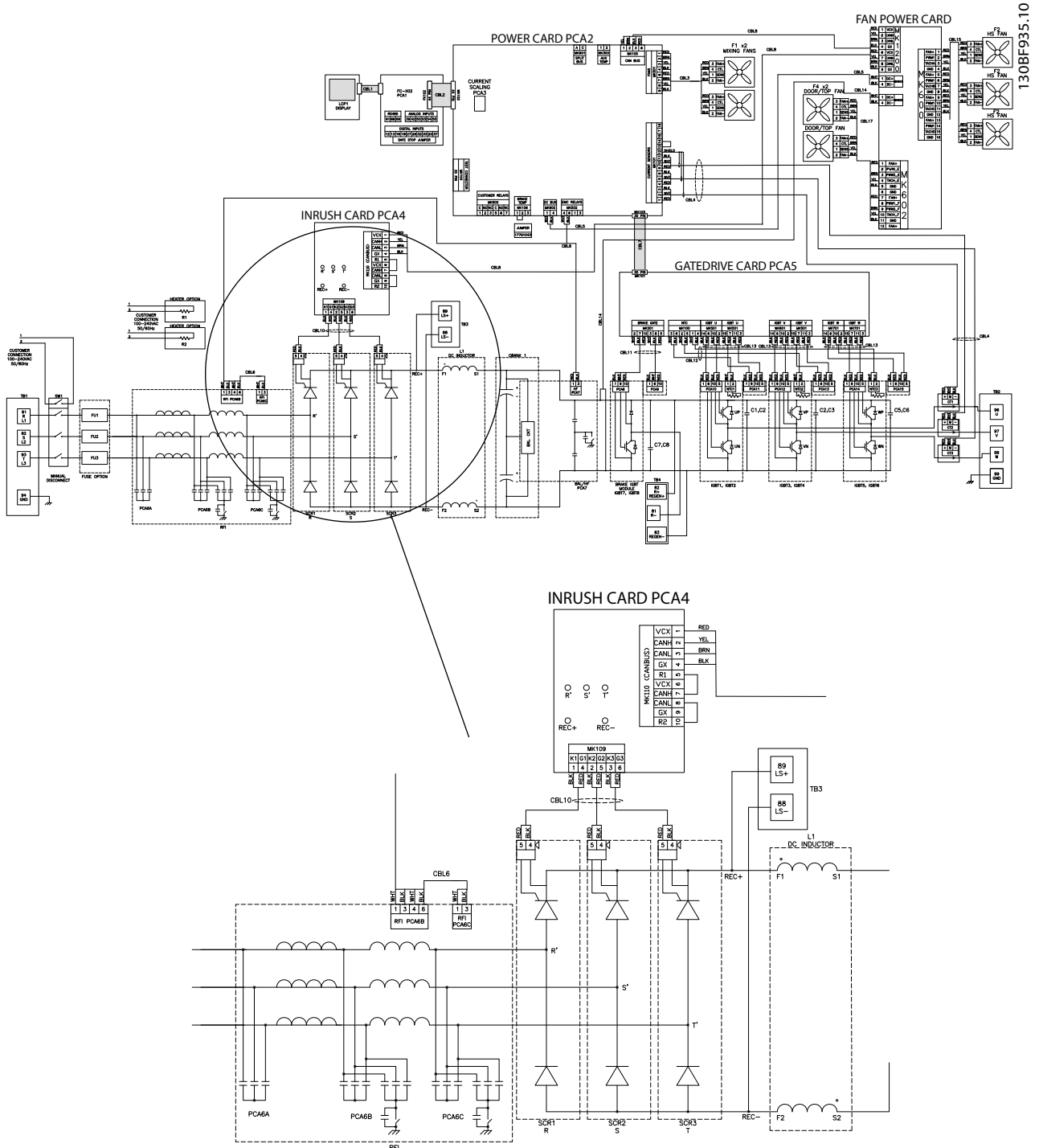

Illustration 5.6 Rectifier Circuit in E-sized Drives

5.3.2 Intermediate Section

Following the rectifier section, voltage passes to the intermediate section (see *Illustration 5.7* and *Illustration 5.8*). An LC filter circuit consisting of the DC bus inductor and the DC bus capacitor bank smooths the rectified voltage.

The DC bus inductor provides series impedance to changing current. It aids the filtering process while reducing harmonic distortion to the input AC current waveform normally present in rectifier circuits.

The DC capacitor bank assembly consists of up to 21 capacitors arranged in series/parallel configuration. The assembly also contains the bleeder/balance circuitry. This circuitry maintains equal voltage drops across each capacitor, and provides a current path for discharging the capacitors when the drive is powered down.

The intermediate section also includes the high frequency (HF) filter card. This card contains a high frequency filter circuit to reduce naturally occurring currents in the HF range to prevent interference with sensitive equipment nearby. The circuit, as with other RFI filter circuitry, can be sensitive to unbalanced phase-to-ground voltages in the 3-phase AC input line. This sensitivity occasionally results in nuisance overvoltage alarms. For this reason, the high frequency filter card contains a set of relay contacts in the ground connection of the filter capacitors. The relay is tied to the RFI/HF switch, which can be switched on or off in *parameter 14-50 RFI Filter*. This setting disconnects the ground references to all filters in case unbalanced phase-to-ground voltages create nuisance overvoltage conditions.

5

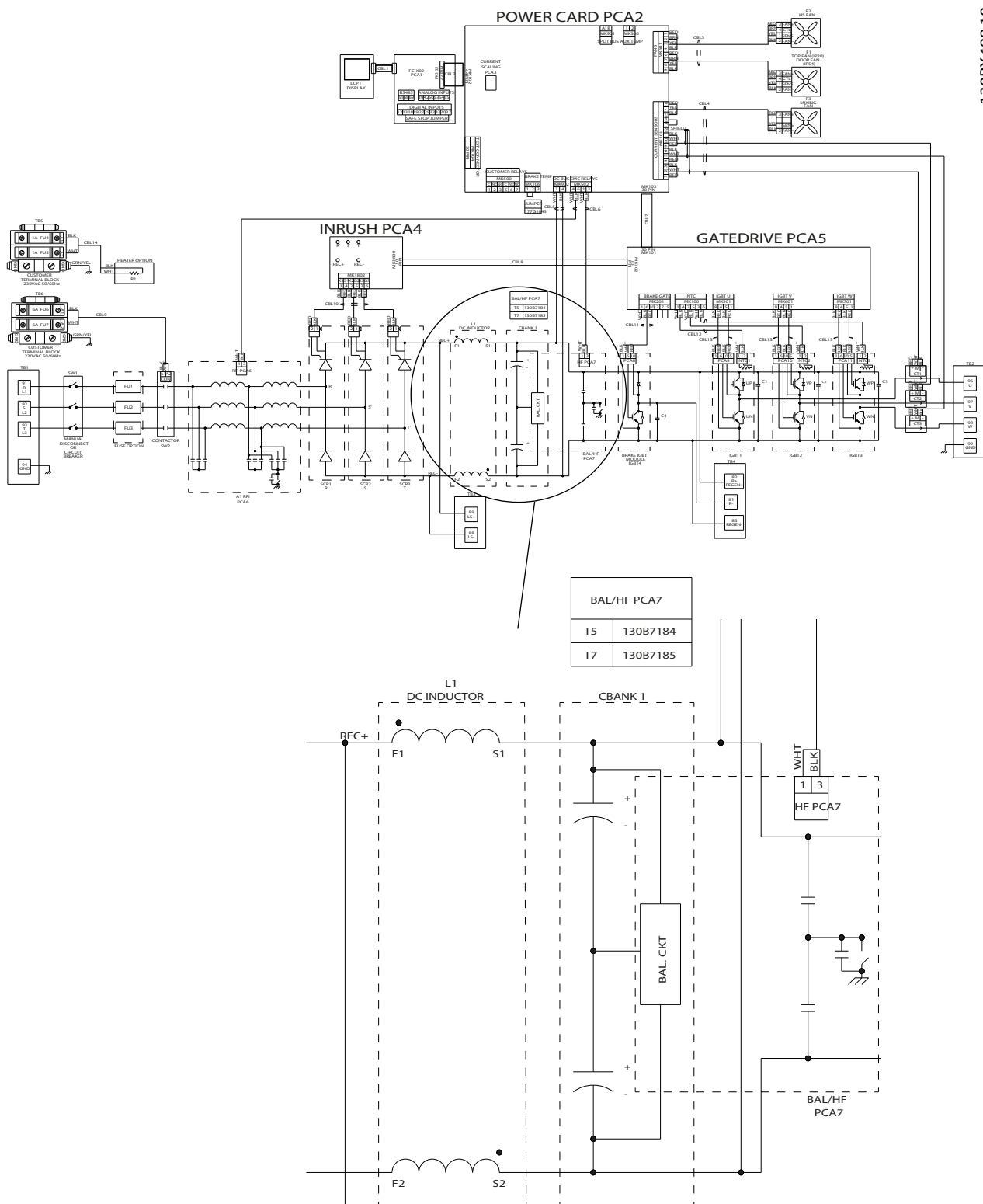

130BX498.10

Illustration 5.7 Intermediate Section in D-sized Drives

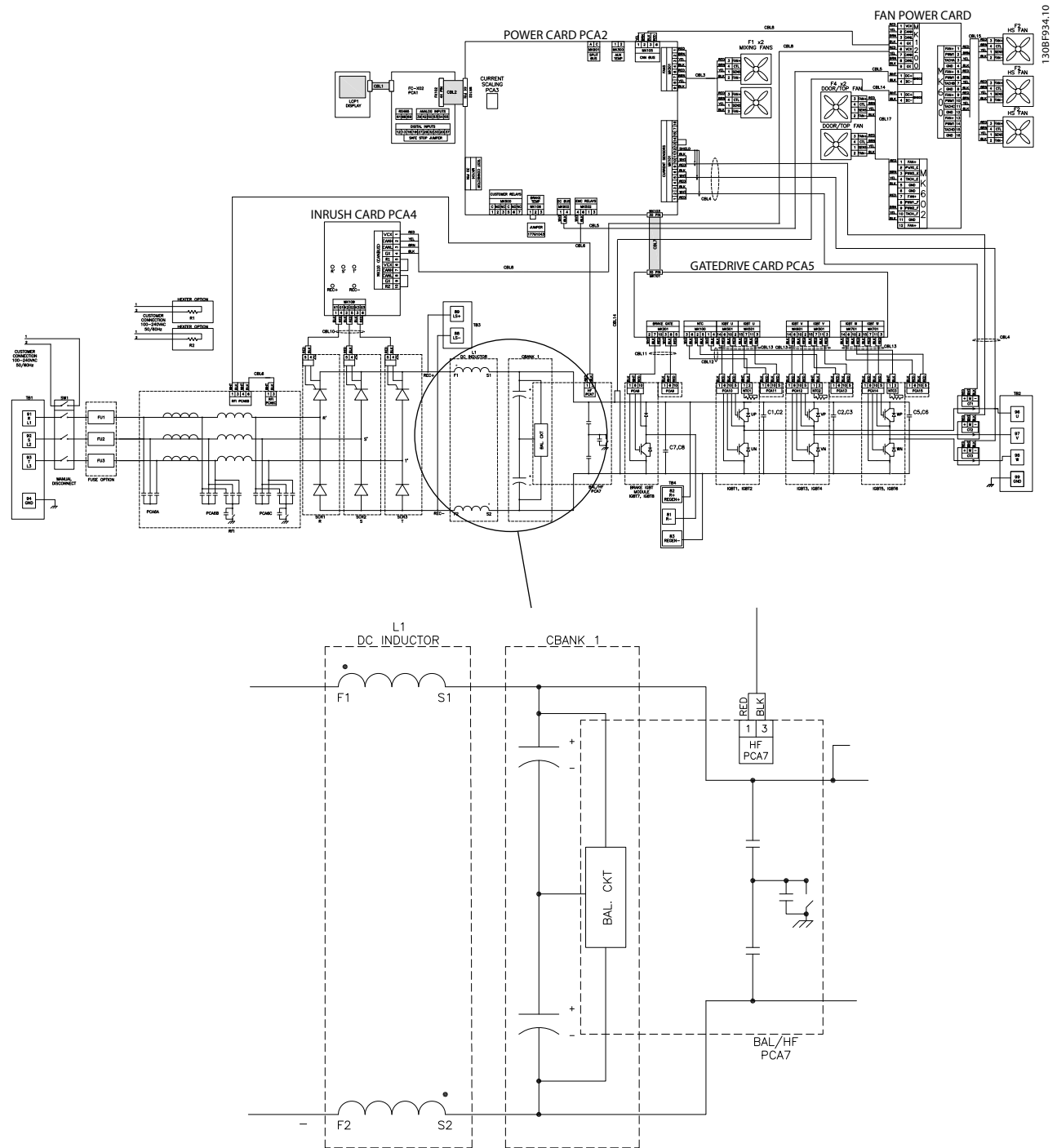

5

Illustration 5.8 Intermediate Section in E-sized Drives

5.3.3 Inverter Section

In the inverter section (see *Illustration 5.10* and *Illustration 5.11*), gate signals are delivered from the control card, through the power card and gate drive card to the gates of the IGBTs. In parallel drive systems, these signals from the individual modules are delivered to the multi-drive control interface card (MDCIC) on the control shelf. The series connection of each set of IGBTs is delivered to the output, first passing through the current sensors.

5

Once a run command and speed reference are present, the IGBTs begin switching to create the output waveform, as shown in *Illustration 5.9*. Looking at the phase-to-phase voltage waveform with an oscilloscope, the pulse width modulation (PWM) principal creates a series of pulses which vary in width.

Basically, the pulses narrow as they approach 0 crossing and grow wider when further away from 0 crossing. The pulse duration of applied DC voltage controls the width. Although the voltage waveform is a consistent amplitude, the inductance within the motor windings averages the voltage delivered. As the pulse width of the waveform varies, the average voltage that the motor detects also varies. The resulting current waveform takes on the sine-wave shape common to an AC system. The rate at which the pulses occur determines the frequency of the waveform. By employing a sophisticated control scheme, the drive delivers a current waveform that nearly replicates a true AC sine-wave.

Hall effect current sensors monitor the output current and deliver proportional signals to the power card where they are buffered and delivered to the control card. In parallel drive systems, these signals pass through the MDCIC on the control shelf. The control card logic uses these current signals to determine proper waveform compensations based on load conditions. They further serve to detect overcurrent conditions, including ground faults and phase-to-phase shorts on the output.

During normal use, the power card and control card are monitoring various functions within the drive. The current sensors provide current feedback information. The DC bus voltage is monitored along with the voltage delivered to the motor. A thermal sensor mounted inside each IGBT module provides heat sink temperature feedback.

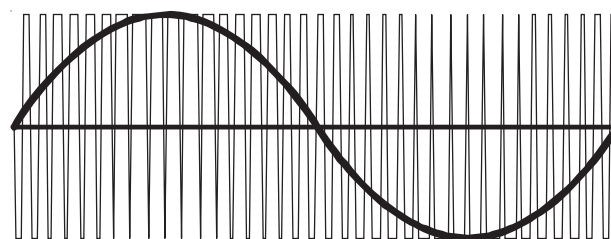

130BX136.10

Illustration 5.9 Output Voltage and Current Waveforms

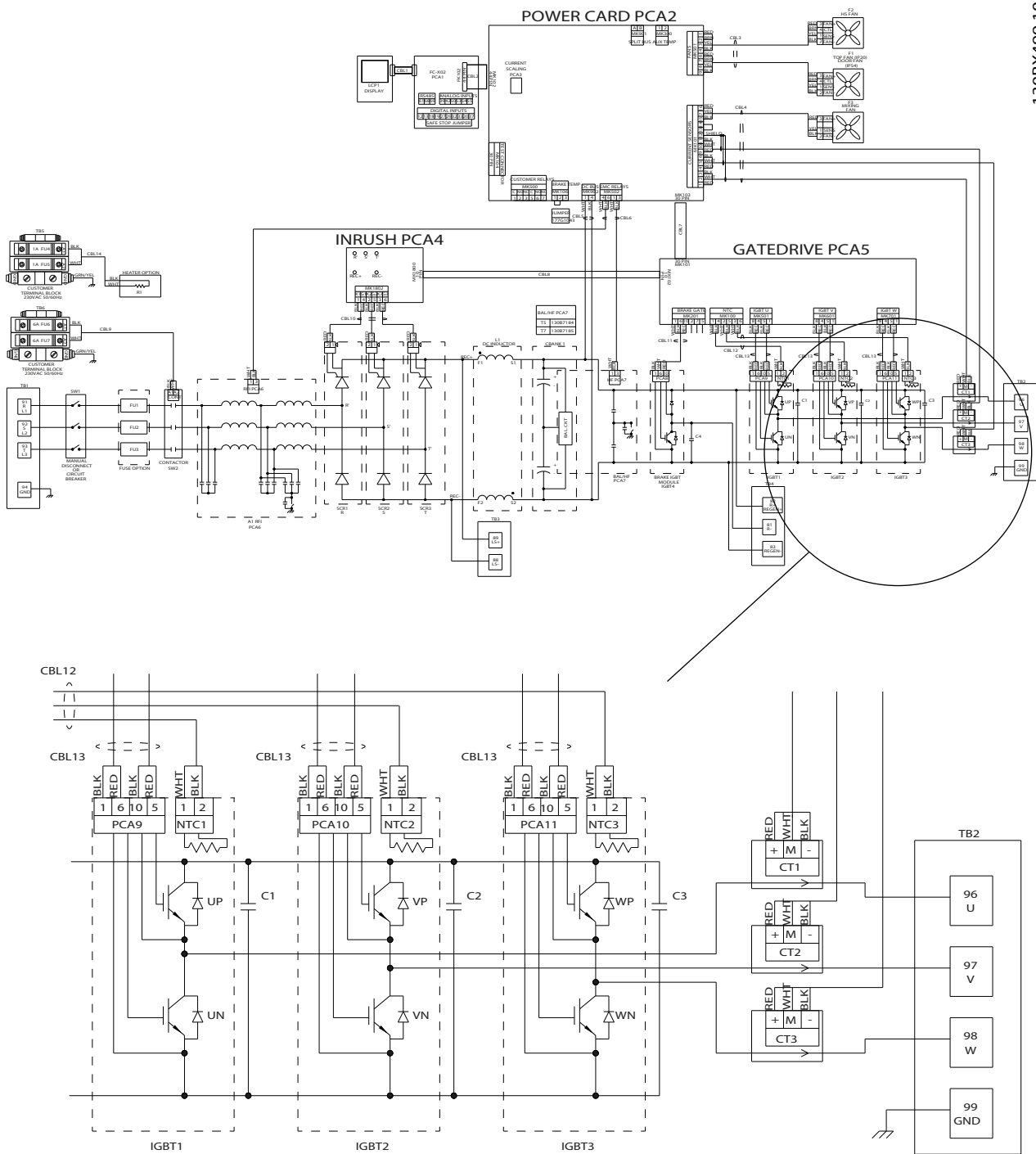

Illustration 5.10 Inverter Section in D-sized Drives

5

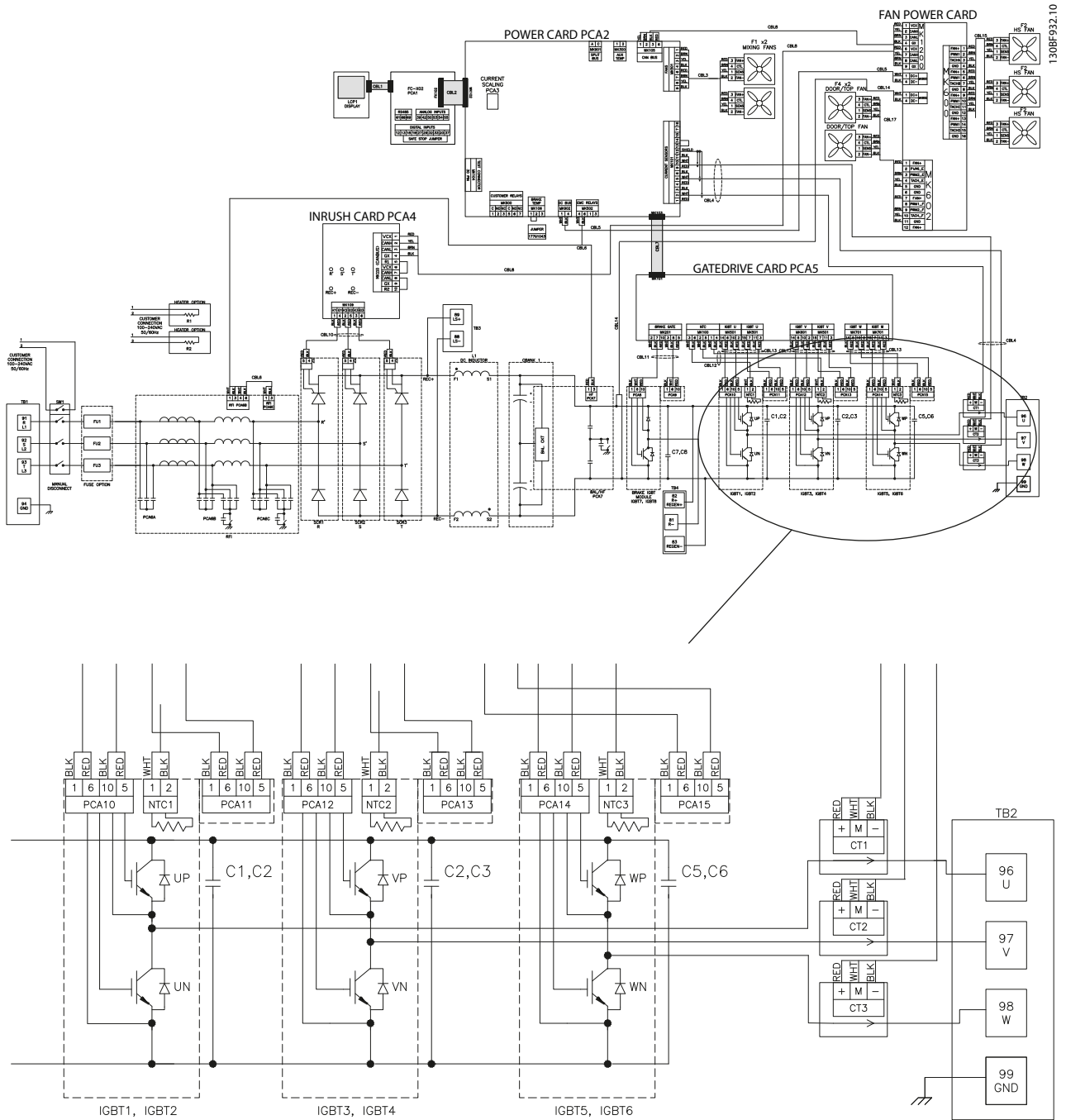

Illustration 5.11 Inverter Section in E-sized Drives

5.3.4 Brake Option

Drives equipped with the dynamic brake option can connect to an external brake resistor using the brake IGBT and terminals 81(R-) and 82(R+).

The function of the brake IGBT (see *Illustration 5.12*) is to limit the voltage in the DC link, whenever the maximum voltage limit is exceeded. To limit the voltage, it switches the externally mounted resistor across the DC bus to remove excess DC voltage from the bus capacitors. Typically, excess DC bus voltage is a result of an overhauling load causing regenerative energy to be returned to the DC bus. This excess occurs, for example, when the load drives the motor causing the voltage to return to the DC bus circuit.

External placement of the brake resistor offers multiple advantages:

- Selecting the resistor based on application need.
- Dissipating the energy outside of the control panel.
- Protecting the drive from overheating when the brake resistor is overloaded.

The brake IGBT gate signal originates on the control card and is delivered to the brake IGBT via the power card and gate drive card. The power and control cards also monitor the brake IGBT and brake resistor connection for short circuits and overloads.

In parallel drive systems, the brake IGBT gate signal originates on the control card. The signal passes through the MDCIC, which delivers it to the power card and gate drive card in each module. The power card and control card also monitor the brake IGBT and brake resistor connection for short circuits and overloads.

5

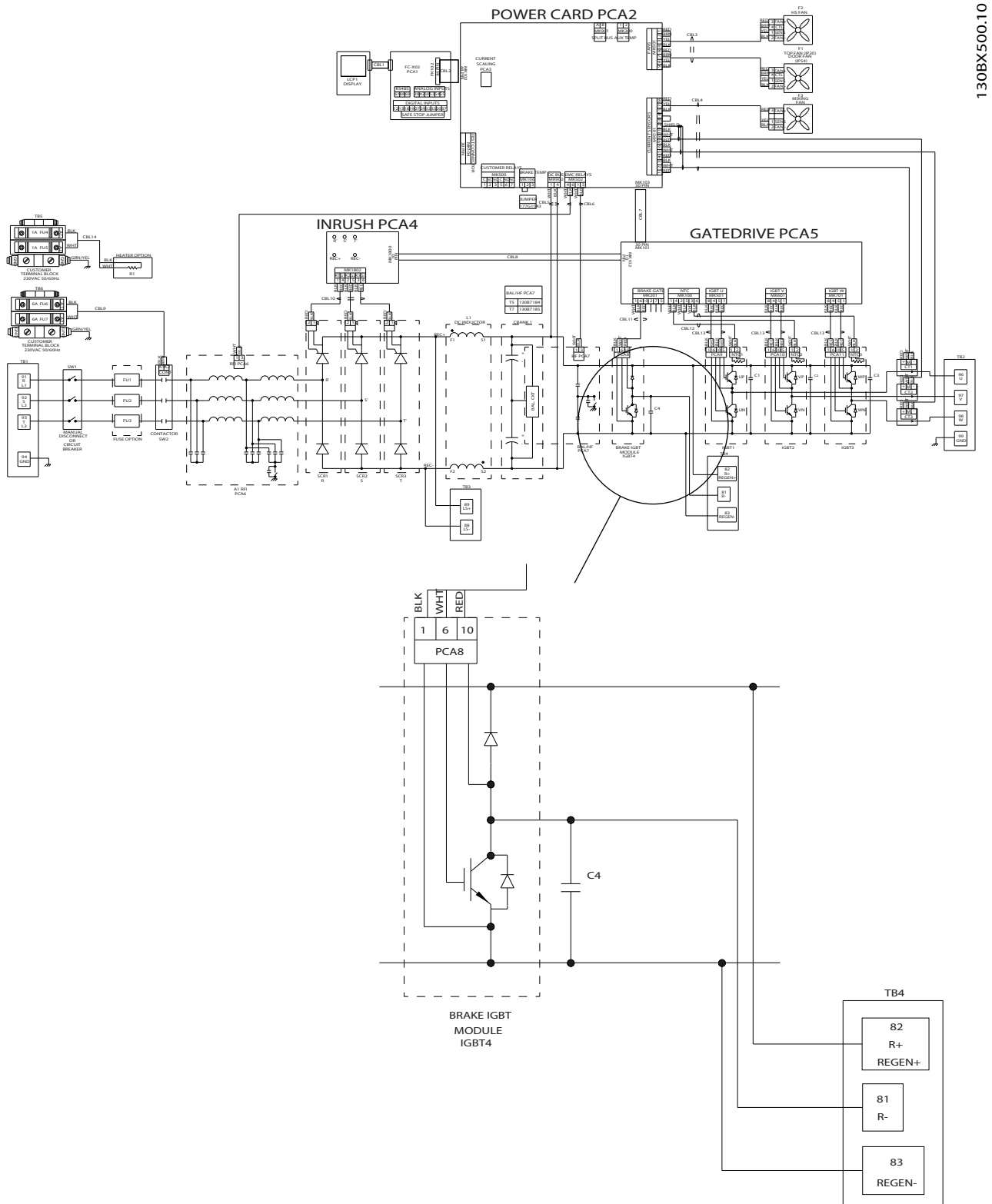

130BX500.10

Illustration 5.12 Brake Option

5.3.5 Cooling Fans

All drives in this size range are equipped with cooling fans to provide airflow for temperature regulation. Each fan has tachometer feedback to the control card to confirm that the fan is operating correctly. On/off and speed control of the fans is provided to reduce overall acoustic noise and extend the life of the fans.

Cooling fans in D-sized and E-sized drives include:

- Mixing fans.
- Heat sink fans.
- Door fans (IP21/IP54).
- Top fans (IP00/IP20).

Mixing fans

In D-sized units, the mixing fan operates any time the drive is powered on. The fan is powered by 24 V DC from the main switch mode power supply, and runs on DC voltage from the power card. The mixing fan is mounted under the input plate.

In E-sized units, the operation of the mixing fans is controlled and the fans run only when commanded. The fans are powered by 48 V DC supply on the power card. In E1h/E3h drives, the 2 mixing fans are mounted on the input plate. In E2h/E4h drives, 1 mixing fan is mounted on the input plate, and 1 fan is mounted below the power card near the IGBT modules.

Heat sink fans

D-sized drives have 1 heat sink fan in the back channel. The heat sink fan runs on DC voltage from the power card. It is powered by 48 V DC from a dedicated switch mode power supply on the power card.

E-sized drives include 3 heat sink fans in the back channel. The heat sink fans are powered from the fan power card.

Door fans

D-sized drives in IP21/IP54 enclosures have door fans. The fans are powered by 48 V DC from a dedicated switch mode power supply on the power card.

E-sized drives in IP21/IP54 enclosures have 2 fans in the door. These door fans are powered from the fan power card.

Top fans

D-sized units in IP00/IP20 enclosures have a fan mounted to the top of the unit for more cooling. The top fan is powered by 48 V DC from a dedicated switch mode power supply on the power card.

E-sized drives in IP00/IP20 enclosures include 2 fans mounted on the top of the drive. The top fans are powered from the fan power card.

Fan activation

The following conditions activate the fans:

- Output current greater than 40% of nominal.
- High IGBT temperature.
- Low IGBT temperature.
- High control card temperature.
- DC hold active.
- DC brake active.
- Dynamic brake circuit active.
- During pre-magnetization of the motor.
- AMA in progress.

In addition to these conditions, the fans are always started shortly after mains input power is applied to the drive. Once fans are started, they run briefly while the system verifies that they are functioning properly.

5.3.6 Fan Speed Control

The following conditions cause the fans to run at full speed:

- Low IGBT temperature.
- Active DC hold.
- Active DC brake.
- Active dynamic brake circuit.
- Pre-magnetization of the motor.
- AMA in progress.

Fan speeds

The fans in E-sized drives have the following maximum speeds.

- Mixing fans: 10000 rpm
- Heat sink fans: 7800 rpm
- Door fans: 6500 rpm
- Top fans: 6500 rpm

Mixing fan

In D-sized drives, the mixing fan runs at full speed whenever the drive has power. In E-sized drives, the fan is controlled and runs only when commanded.

Heat sink fan

The IGBT temperature and the output current determine the speed of the heat sink fan. The fan runs at the higher of the 2 settings.

In D-sized drives, if the output is greater than 84% of the nominal current, the fan runs at 100% speed. If the output current is less than 40% of the nominal current, the fan turns off. When the IGBT temperature reaches the fan turn-on temperature, the fan starts and runs at its minimum speed. As the IGBT temperature increases, the fan speed increases. When the IGBT temperature reaches the fan maximum speed temperature, the fan is running at 100% speed. As the IGBT temperature decreases, the fan speed

decreases. The fan stops running when the IGBT temperature drops below the fan turn-off temperature.

- Fan turn-on temperature = 70 °C (158 °F)
- Fan minimum speed temperature = 70 °C (158 °F)
- Fan maximum speed temperature = 85 °C (185 °F)
- Fan turn-off temperature = 70 °C (158 °F)

In parallel drive systems, the speed of the heat sink fans is based on the IGBT temperature of the warmest drive module.

In E-sized drives, the fan is not set to turn on/off at specific temperatures. Instead, the fan is set to maintain a target temperature, so the temperature at which the fan turns on/off is variable. The target temperature is determined by the setting in *parameter 30-50 Heat Sink Fan Mode*. The fan turns on at 40% load and increases in speed up to 84% load, where the fan is at 100% speed.

Door/top fan

The speed of the door/top fan is determined by:

- Control card temperature.
- IGBT temperature.
- Output current.

The fan runs at the highest of the 3 settings.

In D-sized drives, if the output is greater than 60% of the nominal current, the fan runs at 100% speed. If the output current is less than 60% of the nominal current, the fan turns off.

In E-sized drives, the fan is not set to turn on/off at specific temperatures. Instead, the fan is set to maintain a target temperature, so the temperature at which the fan turns on/off is variable. The target temperature is determined by the setting in *parameter 30-50 Heat Sink Fan Mode*. The fan turns on at 40% load and increases in speed up to 84% load, where the fan is at 100% speed.

When the IGBT temperature reaches the fan turn-on temperature, the fan starts and runs at its minimum speed. As the IGBT temperature increases, the fan speed increases. When the IGBT temperature reaches the fan maximum speed temperature, the fan is running at 100% speed. As the IGBT temperature decreases, the fan speed decreases. The fan stops running when the IGBT temperature drops below the fan turn-off temperature.

- Fan turn-on temperature = 70 °C (158 °F)
- Fan minimum speed temperature = 70 °C (158 °F)
- Fan maximum speed temperature = 85 °C (185 °F)

- Fan turn-off temperature = 70 °C (158 °F)

When the control card temperature reaches the fan turn-on temperature, the fan starts and runs at its minimum speed. As the control card temperature increases, the fan speed increases. When the control card temperature reaches the fan maximum speed temperature, the fan is running at 100% speed. As the control card temperature decreases, the fan speed decreases. The fan stops running when the control card temperature drops below the fan turn-off temperature.

In parallel drive systems, temperature readings are taken for each individual module. Activation and speed control of the module fans are synchronized through the MDCIC.

- Fan turn-on temperature = 40 °C (104 °F)
- Fan minimum speed temperature = 40 °C (104 °F)
- Fan maximum speed temperature = 70 °C (158 °F)
- Fan turn-off temperature = 35 °C (95 °F)

Parameter 14-52 Fan Control commands the fans to run at a fixed speed. If the fans are commanded to run at 100% speed, this setting overrides any other speed command.

In parallel drive systems, the function of the fans in the individual modules is controlled in parallel through the MDCIC. The fan speeds of the individual modules are maintained equally using the control.

5.3.7 Load Sharing and Regen

Units with the built-in load sharing option contain terminals 89 DC(+) and 88 DC(-). Within the drive, these terminals connect to the DC bus on the input side of the DC link reactor. The use of the load sharing terminals has 2 configurations.

In the 1st configuration, the terminals are used to tie the DC bus circuits of multiple drives together. This configuration allows a drive in a regenerative mode to share its excess bus voltage with another drive in motoring mode. This configuration reduces the need for external dynamic brake resistors while also saving energy. Any number of drives can be connected in this way, as long as they are of the same voltage rating. Also, it can be necessary to install DC reactors and DC fuses and mains AC reactors on the mains. Attempting such a configuration requires detailed considerations. Do not attempt without first consulting Danfoss Application Engineering.

In the 2nd configuration, the drive is powered exclusively from a DC source. An external DC source is required. Do not attempt without first consulting Danfoss Application Engineering.

Units with a built-in Regen option contain terminals 82 DC(+) and 83 DC(-). Within the drive, the Regen terminals connect to the DC bus on the output side of the DC-link reactor.

Use Regen terminals to connect a single drive to an external Regen module. Do not use the Regen terminals to connect together the DC bus circuits of multiple drives.

NOTICE

Regen is applicable to parallel drive systems; load sharing is not. Individual modules have Regen terminals, which are used to parallel the drives to achieve high power. To connect to an external Regen unit, use a DC fuse suited for Regen.

5

5.3.8 Specific Power Card Connections

Connector MK106 terminals 104, 105, and 106 on the power card allow for the connection of an external temperature switch. The input can be used to monitor the temperature of an external brake resistor. Two input configurations are possible: If the input state changes, the drive trips issuing *alarm 27, Brake Chopper Fault*. If no such input is used, or the normally open configuration is selected, a jumper must be installed between terminals 104 and 106.

- A normally closed switch connected between terminals 104 and 106.
- A normally open switch between terminals 104 and 105.

MK500 terminals 1, 2, and 3, and 4, 5, and 6, provide access to 2 auxiliary relays. These relays create a form C contact, meaning a normally open and a normally closed contact on a single throw. The contacts are rated for a maximum of 240 V AC, 2 A, and a minimum of 24 V DC, 10 mA, or 24 V AC, 100 mA. The relays can be programmed via *parameter 5-40 Function Relay* to indicate drive status.

NOTICE

In parallel drive systems, the MK500 connector is found on the control shelf. Terminals 104 and 106 are extended to the top of each module through a wiring harness. The terminals are on the top of each module near the DC fuse.

6 Troubleshooting

6

6.1 Troubleshooting Tips

- Some points in the drive are referenced to the negative DC bus. These points are at bus potential even though diagrams can show them as a neutral reference.
- If any of the DC bus fuses are blown, always ensure that no DC bus voltage is present on either side of the DC fuses. When any DC bus fuse is blown, capacitor banks in the other modules are no longer electrically connected. As a result, a module can have stored voltage even when the rest of the system has none.
- Do not assume that the drive contains no voltage when the LCP indicator lights are off.
- Never apply power to a unit that is suspected of being faulty. Many faulty components within the drive can damage other components when power is applied. Always complete the steps described in *chapter 8.6 After-repair Tests*.
- With an external supply and cable assembly, the logic section of the drive can be powered without applying power to the rest of the unit. This method of power isolation is recommended for troubleshooting logic problems.
- Never attempt to defeat any fault protection circuitry within the drive. Doing so results in unnecessary component damage and can cause personal injury.
- Always use factory approved replacement parts. The drive has been designed to operate within certain specifications. Incorrect parts can affect tolerances and damage the unit.
- Read the instruction and service guides. A thorough understanding of the unit is the best approach. If in doubt, consult the factory or authorized repair center for assistance.

6.2 Exterior Fault Troubleshooting

Servicing a drive that has been operational for an extended period is slightly different from a new installation. When using proper troubleshooting procedures on a long-term installation, do not assume that a motor is wired properly. Look for issues such as loose connections, improper programming, or added equipment. It is best to develop a detailed approach, beginning with a physical inspection of the system. Refer to *Table 6.1*.

6.3 Fault Symptom Troubleshooting

This troubleshooting section is organized based on the symptom being experienced. Refer to *chapter 6.5 Fault Symptoms*.

Typical symptoms include:

- Unrecognizable display on the LCP.
- Problems with motor operation.
- Warning or alarm shown by the drive.

The drive processor monitors inputs and outputs along with internal drive functions. Thus, an alarm or warning does not necessarily indicate a problem within the drive itself. For a list of warnings and alarms, refer to *Table 6.2*.

Chapter 6.7 Alarm and Warning Definitions describes how to troubleshoot that particular symptom. When necessary, detailed discussions of drives and system troubleshooting are provided in this chapter for the qualified repair technician to analyze the problem effectively.

Always perform a system test when the following conditions apply:

- Starting a drive for the first time.
- Approaching a drive that is suspected of being faulty.
- After a repair to the drive.

Refer to *chapter 8.6 After-repair Tests*.

6.4 Visual Inspection

Table 6.1 lists conditions that require visual inspection as part of any initial troubleshooting procedure.

Inspect for	Description
Auxiliary equipment	Check auxiliary equipment, switches, disconnects, or input fuses/circuit breakers on the input side of the drive or the output side to the motor. Check the function and installation of pressure sensors, encoders, or other devices that provide feedback to the drive.
Cable routing	Avoid routing the following in parallel: <ul style="list-style-type: none"> • Motor wiring • Mains wiring • Signal wiring If parallel routing is unavoidable, maintain a separation of 150–200 mm (6–8 in) between cables, or separate them with a grounded conductive partition. Avoid routing cables through free air.
Control wiring	Check for broken or damaged wires and connections. In parallel drive systems, check connections between the control shelf and the modules. Check the voltage source of the signals. Use of shielded cable or a twisted pair is recommended. Ensure that the shield is terminated correctly. See <i>chapter 4.9 Shielded Cable Grounding</i> .
Cooling	Check the operation of all cooling fans. Check the door filters on IP21 (UL type 1)/IP54 (UL type 12) units. Check for blocked air passages. Verify that the bottom gland plate is installed. Check the positive and negative interconnections between modules.
DC fuse microswitch	In parallel drive systems, check that microswitches have been snapped properly on to DC fuse fixtures.
DC fuse mounting	In parallel drive systems, check both ends of DC fuses for loose connections.
Display	Check the LCP display for warning/alarm messages, system status, and fault history.
Interior	Check that the drive interior is free of dirt, metal chips, moisture, and corrosion. Check for burnt or damaged power components, or carbon deposits resulting from component failure. Check for cracks in the housings of power semiconductors, or for pieces of broken component housings inside the unit.
EMC considerations	Check for proper installation regarding electromagnetic compatibility (EMC). Refer to the drive operating instructions and <i>chapter 7.3 Electromagnetic Compatibility</i> .
Environmental conditions	The drive can operate within a maximum ambient temperature of 50 °C (122 °F). Humidity levels must be less than 95% non-condensing. Check for harmful airborne contaminants such as sulphur-based compounds.
Grounding	The drive requires a dedicated ground wire from its enclosure to the building ground. Grounding the motor to the drive enclosure is recommended. The use of a conduit or mounting the drive onto a metal surface is not considered a suitable ground. Check that ground connections are tight and free of oxidation.
Input power wiring	Check for loose connections, proper fusing, and blown fuses. In parallel drive systems, check cable length and cross-section imbalance between the terminals of the modules.
Motor	Check the nameplate ratings of the motor. Ensure that the motor ratings correspond with the drive ratings. Check that the motor parameters (<i>parameter 1-20 Motor Power [kW]</i> to <i>parameter 1-25 Motor Nominal Speed</i>) are set according to the motor ratings.
Output to motor wiring	Check for loose connections. Check for switching components in the output circuit. Check for faulty contacts in the switchgear. In parallel drive systems, check for proper interconnections between the modules. Check cable length and cross-section imbalance between the terminals of the modules. One missing wire can cause an overcurrent trip.
Programming	Make sure that the drive parameter settings are correct according to motor, application, and I/O configuration.
Proper clearance	Drives require adequate top and bottom clearance to ensure proper airflow for cooling. Drives with exposed heat sinks (in the back) must be mounted on a flat solid surface.
Vibration	Look for unusual amounts of vibration around the drive. Mount the unit solidly or use shock mounts.

Table 6.1 Visual Inspection

6.5 Fault Symptoms

6.5.1 No Display

- Check that power is supplied.
- Cycle power to the unit.
- Reinitialize the drive (refer to *chapter 4.2.5 Restoring Factory Default Settings*).

6.5.2 Intermittent Display

Cutting out or flashing of the entire display and power LED indicates that the supply (SMPS) is shutting down due to an overload. Check for:

- Improper control wiring.
- Overload of the supply output (18 V, 24 V, 48 V).
- Fault within the drive.

Check for a problem in the control wiring by disconnecting all control wiring from the control terminal blocks on the installation card.

If the display stays lit, then the problem is in the control wiring (external to the drive). Check all control wiring for shorts or incorrect connections.

If the display continues to cut out, refer to *chapter 6.5.1 No Display*.

6.5.3 Motor Does Not Run

If this symptom is detected, first verify that the unit is properly powered up (display is lit) and that no warning or alarm messages are shown. The most common cause is either incorrect control logic or an incorrectly programmed drive. Such occurrences result in 1 or more of the following status messages being shown.

Cause: LCP Stop

Action: The [Off] key has been pressed.

Press the [Auto On] or [Hand On] key.

Cause: Standby

This condition indicates that there is no start signal at terminal 18.

Action: Ensure that a start command is present at terminal 18. Refer to *chapter 8.5.14 Input Terminal Signal Tests*.

Cause: Unit ready

Terminal 27 is low (no signal).

Action: Ensure that terminal 27 is logic 1. Refer to *chapter 8.5.14 Input Terminal Signal Tests*.

Run OK, 0 Hz

This message indicates that a run command has been given to the drive, but the reference (speed command) is 0 or missing.

To ensure that the proper reference signal is present at the drive input terminals, check the control wiring. Also check that the unit is programmed properly to accept the signal. Refer to *chapter 8.5.14 Input Terminal Signal Tests*.

Off 1 (2 or 3)

This message indicates that bit #1 (or #2, or #3) in the control word is logic 0. This situation only occurs when the drive is being controlled via the fieldbus.

A correct control word must be transmitted to the drive over the communication bus to correct this error.

STOP

One of the digital input terminals 18, 19, 27, 29, 32, or 33 (*parameter group 5-1* Digital Inputs*) is programmed for [6] *Stop Inverse*. The corresponding terminal is low (logic 0).

Ensure that the parameters are programmed correctly and that any digital input programmed for [6] *Stop Inverse* is high (logic 1).

DC undervolt

If the unit is equipped with an external 24 V DC option, check that mains power is supplied to the drive.

6.5.4 Incorrect Motor Operation

Occasionally, a fault occurs when the motor continues to run, but not in the correct manner. Possible causes are listed by symptom.

Wrong speed; unit does not respond to command

Cause: Possible incorrect reference (speed command).

Action: Check that the unit is programmed correctly for the relevant reference signal, and that all reference limits are set correctly. To check for faulty reference signals, see *chapter 8.5.14 Input Terminal Signal Tests*.

Motor speed unstable

Cause:

- Incorrect parameter settings.
- Faulty current feedback circuit.
- Loss of motor (output) phase.

Action: Check the settings of all motor parameters, including motor compensation settings such as slip compensation and load compensation. For closed-loop operation, check PID settings. To check for faulty reference signals, refer to *chapter 8.5.14 Input Terminal Signal Tests*. To check for loss of motor phase, refer to *chapter 8.5.9 Output Imbalance of Motor Voltage and Current*.

Motor runs rough

Cause:

- Possible overmagnetization.
- IGBT misfiring.
- Motor under heavy load.
- *Alarm 13, Overcurrent* tripping intermittently.

In parallel drive modules:

- Missing output connection in an individual drive module.
- Missing DC link connections.

Action: Check settings of all motor parameters. Refer to *chapter 8.5.9 Output Imbalance of Motor Voltage and Current*. If output voltage is unbalanced, perform the *chapter 8.5.11 IGBT Gate Drive Signals Test*. In parallel drive systems, check the modules for loose connections.

Motor draws high current, but cannot start

Cause: Possible open winding in motor or open phase in connection to motor.

Action: To check the motor for opening windings and unbalanced resistance, run an AMA. To ensure that the drive is providing correct output, refer to *chapter 8.5.9 Output Imbalance of Motor Voltage and Current*. If output voltage is unbalanced, perform the *chapter 8.5.11 IGBT Gate Drive Signals Test*. Inspect all motor wiring connections.

Motor does not brake

Cause: Possible fault in the brake circuit. Possible incorrect setting in the brake parameters. The ramp-down time is too short. The LCP shows an alarm or warning message.

Action: Check all brake parameters and ramp-down time (*parameter groups 2-0* DC-Brake and 3-4* Ramp 1*). Perform the procedures in *chapter 8.4.3 Brake IGBT Test*.

6.6 Alarms and Warnings**6.6.1 Overview of Alarms and Warnings**

The drive indicates a warning or an alarm by the relevant indicator light on the LCP and a code on the display.

A warning remains active until its cause is no longer present. Under certain circumstances, operation of the motor can be continued. Warning messages can be critical, but are not necessarily so.

An alarm indicates that the drive tripped. The alarm must be reset to restart operation once its problem is fixed.

Resetting can be done in any of 4 ways:

- By using the [Reset] control key on the LCP.
- Via a digital input with the reset function.
- Via serial communication/optional fieldbus.
- By resetting automatically using the [Auto Reset] function.

NOTICE**MANUAL RESET**

After a manual reset using the [RESET] key on the LCP, the [Auto On] key must be pressed to restart the motor.

If an alarm cannot be reset, it is possible that the problem is not fixed or that the alarm is a trip lock. Refer to *Table 6.2*.

Trip lock alarms offer extra protection, since the mains supply must be switched off before the alarm can be reset. After being switched back on, the drive is no longer blocked and can be reset once the problem is fixed.

Alarms that are not trip locks also can be reset using the automatic reset function in *parameter 14-20 Reset Mode*.

WARNING**AUTOMATIC RESET**

Automatic reset is not recommended in industrial applications where it can unexpectedly cause the drive and motor to restart. Failure to use manual reset in industrial applications can cause death or serious injury.

- Always use the manual restart setting in *parameter 14-20 Reset Mode*.

If both a warning and alarm are marked for a code in *Table 6.2*, it means that either:

- A warning occurs before an alarm.
- It can be specified whether a warning or an alarm is shown for a given fault.

This situation is possible, for instance, in *parameter 1-90 Motor Thermal Protection*.

After an alarm or trip, the motor coasts, and the alarm and warning flash on the drive. Once the problem has been fixed, only the alarm continues flashing.

6.6.2 Alarm/Warning Identification Tables

Number	Description	Warning	Alarm/trip	Alarm/trip lock
1	10 V low	X	–	–
2	Live zero error	(X)	(X)	–
3	No motor	(X)	–	–
4	Mains phase loss	(X)	(X)	(X)
5	DC-link voltage high	X	–	–
6	DC-link voltage low	X	–	–
7	DC overvoltage	X	X	–
8	DC undervoltage	X	X	–
9	Inverter overloaded	X	X	–
10	Motor overtemperature	(X)	(X)	–
11	Motor thermistor overtemperature	(X)	(X)	–
12	Torque limit	X	X	–
13	Overcurrent	X	X	X
14	Ground fault	X	X	X
15	Hardware mismatch	–	X	X
16	Short circuit	–	X	X
17	Control word timeout	(X)	(X)	–
18	Start failed	–	X	–
19	Discharge temperature high	X	X	–
20	Temperature input error	X	X	–
21	Parameter error	X	X	–
22	Hoist mechanical brake	(X)	(X)	–
23	Internal fan fault	X	–	–
24	External fan fault	X	–	–
25	Brake resistor short circuit	X	–	–
26	Brake resistor power limit	(X)	(X)	–
27	Brake chopper fault	X	X	–
28	Brake check failed	(X)	(X)	–
29	Heat sink temp	X	X	X
30	Motor phase U missing	(X)	(X)	(X)
31	Motor phase V missing	(X)	(X)	(X)
32	Motor phase W missing	(X)	(X)	(X)
33	Inrush fault	–	X	X
34	Fieldbus communication fault	X	X	–
35	Option fault	(X)	–	–
36	Mains failure	X	X	–
37	Phase imbalance	–	X	–
38	Internal fault	–	X	X
39	Heat sink sensor	–	X	X
40	Overload of digital output terminal 27	(X)	–	–
41	Overload of digital output terminal 29	(X)	–	–
42	Overload X30/6 or X30/7	(X)	–	–
43	External supply	–	X	–
45	Ground fault 2	X	X	X
46	Power card supply	–	X	X
47	24 V supply low	X	X	X
48	1.8 V supply low	–	X	X
49	Speed limit	X	–	–
50	AMA calibration failed	–	X	–
51	AMA check U_{nom} and I_{nom}	–	X	–

Number	Description	Warning	Alarm/trip	Alarm/trip lock
52	AMA low I_{nom}	-	X	-
53	AMA motor too large	-	X	-
54	AMA motor too small	-	X	-
55	AMA parameter out of range	-	X	-
56	AMA interrupted by user	-	X	-
57	AMA timeout	-	X	-
58	AMA internal fault	X	X	-
59	Current limit	X	-	-
60	External interlock	X	X	-
61	Feedback error	(X)	(X)	-
62	Output frequency at maximum limit	X	-	-
63	Mechanical brake low	-	(X)	-
64	Voltage limit	X	-	-
65	Control card overtemperature	X	X	X
66	Heat sink temperature low	X	-	-
67	Option configuration has changed	-	X	-
68	Safe stop activated	(X)	(X) ¹⁾	-
69	Power card temperature	-	X	X
70	Illegal FC configuration	-	-	X
71	PTC 1 safe stop	X	X	-
72	Dangerous failure	X	X	X
73	Safe stop auto restart	(X)	(X)	-
74	PTC thermistor	-	-	X
75	Illegal profile sel.	-	X	-
76	Power unit setup	X	-	-
77	Reduced power mode	X	-	-
78	Tracking error	(X)	(X)	-
79	Illegal power section configuration	-	X	-
80	Drive initialized to default value	-	X	-
81	CSIV corrupt	-	X	-
82	CSIV parameter error	-	X	-
83	Illegal option combination	-	-	X
84	No safety option	-	X	-
85	Dang fall PB	-	X	-
88	Option detection	-	-	X
89	Mechanical brake sliding	X	-	-
90	Feedback monitor	(X)	(X)	-
91	Analog input 54 wrong settings	-	-	X
92	No flow	(X)	(X)	-
93	Dry pump	(X)	(X)	-
94	End of curve	(X)	(X)	-
95	Broken belt	(X)	(X)	-
96	Start delayed	(X)	-	-
97	Stop delayed	(X)	-	-
98	Clock fault	X	-	-
99	Locked rotor	-	X	-
104	Mixing fan fault	(X)	(X)	-
122	Motor rotat. unexp.	X	X	-
144	Inrush supply	-	X	-
145	External SCR disable	-	X	-
146	Mains voltage	X	X	-
147	Mains frequency	X	X	-

Number	Description	Warning	Alarm/trip	Alarm/trip lock
148	System temp	X	X	–
163	ATEX ETR cur.lim.warning	X	–	–
164	ATEX ETR cur.lim.alarm	–	X	–
165	ATEX ETR freq.lim.warning	X	–	–
166	ATEX ETR freq.lim.alarm	–	X	–
200	Fire mode	(X)	–	–
201	Fire mode was active	(X)	–	–
202	Fire mode limits exceeded	(X)	–	–
203	Missing motor	(X)	–	–
204	Locked rotor	(X)	–	–
219	Compressor interlock	(X)	–	–
243	Brake IGBT	X	X	–
244	Heat sink temperature	X	X	X
245	Heat sink sensor	–	X	X
246	Power card supply	–	X	X
247	Power card temperature	–	X	X
248	Illegal power section configuration	–	X	X
250	New spare part	–	–	X
251	New type code	–	X	X
421	Temperature fault	–	X	–
422	FPC communication	–	X	X
423	FPC updating	–	X	–
424	FPC update successful	–	X	–
425	FPC update failure	–	X	–
426	FPC config	–	X	–
427	FPC supply	–	X	–

Table 6.2 Alarm/Warning Code List

(X) This variable is programmable. Warnings/alarms depend on parameter setting.

1) Cannot be auto reset via parameter selection.

LED indication	
Warning	Yellow
Alarm	Red (flashing)
Trip lock	Yellow and red

Table 6.3 Description of LED Indicator Lights

Alarm word and extended status word					
Bit	Hex	Dec	Alarm word	Warning word	Extended status word
0	00000001	1	Brake check	Brake check	Ramping
1	00000002	2	Pwr. card temp	Pwr. card temp	AMA running
2	00000004	4	Ground fault	Ground fault	Start CW/CCW
3	00000008	8	Ctrl. card temp	Ctrl. card temp	Slow down
4	00000010	16	Ctrl. word TO	Ctrl. word TO	Catch up
5	00000020	32	Overcurrent	Overcurrent	Feedback high
6	00000040	64	Torque limit	Torque limit	Feedback low
7	00000080	128	Motor Th over	Motor Th over	Output current high
8	00000100	256	Motor ETR over	Motor ETR over	Output current low
9	00000200	512	Inverter overl.	Inverter overl.	Output freq high
10	00000400	1024	DC under volt	DC under volt	Output freq low
11	00000800	2048	DC over volt	DC over volt	Brake check ok
12	00001000	4096	Short circuit	DC voltage low	Braking max
13	00002000	8192	Inrush fault	DC voltage high	Braking
14	00004000	16384	Mains ph. loss	Mains ph. loss	Out of speed range
15	00008000	32768	AMA not OK	No motor	OVC active
16	00010000	65536	Live zero error	Live zero error	-
17	00020000	131072	Internal fault	10 V low	-
18	00040000	262144	Brake overload	Brake overload	-
19	00080000	524288	U phase loss	Brake resistor	-
20	00100000	1048576	V phase loss	Brake IGBT	-
21	00200000	2097152	W phase loss	Speed limit	-
22	00400000	4194304	Fieldbus fault	Fieldbus fault	-
23	00800000	8388608	24 V supply low	24 V supply low	-
24	01000000	16777216	Mains failure	Mains failure	-
25	02000000	33554432	1.8 V Supply low	Current limit	-
26	04000000	67108864	Brake resistor	Low temp	-
27	08000000	134217728	Brake IGBT	Voltage limit	-
28	10000000	268435456	Option change	Unused	-
29	20000000	536870912	Drive initialized	Unused	-
30	40000000	1073741824	Safe Torque Off	Unused	-

Table 6.4 Description of Alarm Word, Warning Word, and Extended Status Word

The alarm words, warning words, and extended status words can be read via fieldbus or optional fieldbus for diagnosis. Also, refer to *parameter 16-90 Alarm Word*, *parameter 16-92 Warning Word*, and *parameter 16-94 Ext. Status Word*.

Bit	Hex	Dec	Alarm word 2	Warning word 2
0	00000001	1	-	Start Delayed
1	00000002	2	-	Stop Delayed
9	00000200	512	Discharge Temperature High	Discharge Temperature High
10	00000400	1024	Start Limit	-
11	00000800	2048	Speed Limit	-

Table 6.5 Description of Alarm Word 2 and Warning Word 2

6.7 Alarm and Warning Definitions

The following warning and alarm information defines each warning or alarm condition, provides the probable cause for the condition, and details a remedy or troubleshooting procedure.

WARNING 1, 10 Volts low

The control card voltage is less than 10 V from terminal 50. Remove some of the load from terminal 50, as the 10 V supply is overloaded. Maximum 15 mA or minimum 590 Ω.

A short circuit in a connected potentiometer or incorrect wiring of the potentiometer can cause this condition.

Troubleshooting

- Remove the wiring from terminal 50. If the warning clears, the problem is with the wiring. If the warning does not clear, replace the control card.

WARNING/ALARM 2, Live zero error

This warning or alarm only appears if programmed in *parameter 6-01 Live Zero Timeout Function*. The signal on 1 of the analog inputs is less than 50% of the minimum value programmed for that input. Broken wiring or a faulty device sending the signal can cause this condition.

Troubleshooting

- Check connections on all analog mains terminals.
 - Control card terminals 53 and 54 for signals, terminal 55 common.
 - VLT® General Purpose I/O MCB 101 terminals 11 and 12 for signals, terminal 10 common.
 - VLT® Analog I/O Option MCB 109 terminals 1, 3, and 5 for signals, terminals 2, 4, and 6 common.
- Check that the drive programming and switch settings match the analog signal type.
- Perform an input terminal signal test.

WARNING/ALARM 3, No motor

No motor has been connected to the output of the drive. This warning or alarm appears only if programmed in *parameter 1-80 Function at Stop*.

Troubleshooting

- Check the connection between the drive and the motor.

WARNING/ALARM 4, Mains phase loss

A phase is missing on the supply side, or the mains voltage imbalance is too high. This message also appears for a fault in the input rectifier. Options are programmed in *parameter 14-12 Function at Mains Imbalance*.

Troubleshooting

- Check the supply voltage and supply currents to the drive.

WARNING 5, DC link voltage high

The DC-link voltage (DC) is higher than the high-voltage warning limit. The limit depends on the drive voltage rating. The unit is still active.

WARNING 6, DC link voltage low

The DC-link voltage (DC) is lower than the low-voltage warning limit. The limit depends on the drive voltage rating. The unit is still active.

WARNING/ALARM 7, DC overvoltage

If the DC-link voltage exceeds the limit, the drive trips after a certain time.

Troubleshooting

- Connect a brake resistor.
- Extend the ramp time.
- Change the ramp type.
- Activate the functions in *parameter 2-10 Brake Function*.
- Increase *parameter 14-26 Trip Delay at Inverter Fault*.
- If the alarm/warning occurs during a power sag, use kinetic back-up (*parameter 14-10 Mains Failure*).

WARNING/ALARM 8, DC under voltage

If the DC-link voltage drops below the undervoltage limit, the drive checks for 24 V DC back-up supply. If no 24 V DC back-up supply is connected, the drive trips after a fixed time delay. The time delay varies with unit size.

Troubleshooting

- Check that the supply voltage matches the drive voltage.
- Perform an input voltage test.
- Perform a soft-charge circuit test.

WARNING/ALARM 9, Inverter overload

The drive has run with more than 100% overload for too long and is about to cut out. The counter for electronic thermal inverter protection issues a warning at 98% and trips at 100% with an alarm. The drive cannot be reset until the counter is below 90%.

Troubleshooting

- Compare the output current shown on the LCP with the drive rated current.
- Compare the output current shown on the LCP with the measured motor current.
- Show the thermal drive load on the LCP and monitor the value. When running above the drive continuous current rating, the counter increases. When running below the drive continuous current rating, the counter decreases.

WARNING/ALARM 10, Motor overload temperature

According to the electronic thermal protection (ETR), the motor is too hot.

Select 1 of these options:

- The drive issues a warning or an alarm when the counter is >90% if *parameter 1-90 Motor Thermal Protection* is set to warning options.
- The drive trips when the counter reaches 100% if *parameter 1-90 Motor Thermal Protection* is set to trip options.

The fault occurs when the motor runs with more than 100% overload for too long.

Troubleshooting

- Check for motor overheating.
- Check if the motor is mechanically overloaded.
- Check that the motor current set in *parameter 1-24 Motor Current* is correct.
- Ensure that the motor data in *parameters 1-20 to 1-25* is set correctly.
- If an external fan is in use, check that it is selected in *parameter 1-91 Motor External Fan*.
- Running AMA in *parameter 1-29 Automatic Motor Adaptation (AMA)* tunes the drive to the motor more accurately and reduces thermal loading.

WARNING/ALARM 11, Motor thermistor overtemp

Check whether the thermistor is disconnected. Select whether the drive issues a warning or an alarm in *parameter 1-90 Motor Thermal Protection*.

Troubleshooting

- Check for motor overheating.
- Check if the motor is mechanically overloaded.
- When using terminal 53 or 54, check that the thermistor is connected correctly between either terminal 53 or 54 (analog voltage input) and terminal 50 (+10 V supply). Also check that the terminal switch for 53 or 54 is set for voltage. Check that *parameter 1-93 Thermistor Source* selects terminal 53 or 54.
- When using terminal 18, 19, 31, 32, or 33 (digital inputs), check that the thermistor is connected correctly between the digital input terminal used (digital input PNP only) and terminal 50. Select the terminal to use in *parameter 1-93 Thermistor Source*.

WARNING/ALARM 12, Torque limit

The torque has exceeded the value in *parameter 4-16 Torque Limit Motor Mode* or the value in *parameter 4-17 Torque Limit Generator Mode*. *Parameter 14-25 Trip Delay at Torque Limit* can change this warning from a warning-only condition to a warning followed by an alarm.

Troubleshooting

- If the motor torque limit is exceeded during ramp-up, extend the ramp-up time.
- If the generator torque limit is exceeded during ramp-down, extend the ramp-down time.
- If torque limit occurs while running, increase the torque limit. Make sure that the system can operate safely at a higher torque.
- Check the application for excessive current draw on the motor.

WARNING/ALARM 13, Over current

The inverter peak current limit (approximately 200% of the rated current) is exceeded. The warning lasts approximately 1.5 s, then the drive trips and issues an alarm. Shock loading or quick acceleration with high-inertia loads can cause this fault. If the acceleration during ramp-up is quick, the fault can also appear after kinetic back-up. If extended mechanical brake control is selected, a trip can be reset externally.

Troubleshooting

- Remove power to the drive.
- Check that the motor shaft can be turned.
- Check that the motor size matches the drive.
- Check that the motor data is correct in *parameters 1-20 to 1-25*.
- For parallel drive systems, check for output cable imbalances in size and length between phases and between drive modules.

ALARM 14, Earth (ground) fault

There is current from the output phase to ground, either in the cable between the drive and the motor, or in the motor itself. The current transducers detect the ground fault by measuring current going out from the drive and current going into the drive from the motor. Ground fault is issued if the deviation of the 2 currents is too large. The current going out of the drive must be the same as the current going into the drive.

Troubleshooting

- Remove power to the drive and repair the ground fault.
- Check for ground faults in the motor by measuring the resistance to ground of the motor cables and the motor with a megohmmeter.
- Reset any potential individual offset in the 3 current transducers in the drive. Perform the manual initialization or perform a complete AMA. This method is most relevant after changing the power card.

ALARM 15, Hardware mismatch

A fitted option is not operational with the present control card hardware or software.

Record the value of the following parameters and contact Danfoss.

- *Parameter 15-40 FC Type.*
- *Parameter 15-41 Power Section.*
- *Parameter 15-42 Voltage.*
- *Parameter 15-43 Software Version.*
- *Parameter 15-45 Actual Typecode String.*
- *Parameter 15-49 SW ID Control Card.*
- *Parameter 15-50 SW ID Power Card.*
- *Parameter 15-60 Option Mounted.*
- *Parameter 15-61 Option SW Version (for each option slot).*

There is short-circuiting in the motor or motor wiring.

⚠ WARNING

HIGH VOLTAGE

Drives contain high voltage when connected to AC mains input, DC supply, or load sharing. Failure to perform installation, start-up, and maintenance by qualified personnel can result in death or serious injury.

ALARM 16, Short circuit

Troubleshooting

- Remove the power to the drive and repair the short circuit.
- Check that the drive contains the correct current scaling card and the correct number of current scaling cards for the system.

WARNING/ALARM 17, Control word timeout

There is no communication to the drive.

The warning is only active when *parameter 8-04 Control Timeout Function* is NOT set to [0] Off.

If *parameter 8-04 Control Timeout Function* is set to [5] Stop and trip, a warning appears, and the drive ramps down to a stop and shows an alarm.

Troubleshooting

- Check the connections on the serial communication cable.
- Increase *parameter 8-03 Control Timeout Time*.
- Check the operation of the communication equipment.
- Verify that proper EMC installation was performed.

ALARM 18, Start failed

The speed has not been able to exceed *parameter 1-77 Compressor Start Max Speed [RPM]* during start within the allowed time that was set in *parameter 1-79 Compressor Start Max Time to Trip*. A blocked motor can cause this alarm.

WARNING/ALARM 19, Discharge temperature high

The warning indicates that the discharge temperature exceeds the level programmed in *parameter 28-24 Warning Level*. If so programmed in *parameter 28-25 Warning Action*, the drive lowers the speed of the compressor in an attempt to lower the discharge temperature.

The alarm indicates that the discharge temperature exceeds the level programmed in *parameter 28-26 Emergency Level*.

WARNING/ALARM 20, Temp. input error

The temperature sensor is not connected.

WARNING/ALARM 21, Parameter error

The parameter is out of range. The parameter number is shown in the display.

Troubleshooting

- Set the affected parameter to a valid value.

WARNING 22, Hoist mechanical brake

0 = The torque reference was not reached before timeout.

1 = There was no brake feedback before the timeout.

WARNING 23, Internal fan fault

The fan warning function is a protective function that checks if the fan is running/mounted. The fan warning can be disabled in *parameter 14-53 Fan Monitor ([0] Disabled)*.

There is a feedback sensor mounted in the fan. If the fan is commanded to run and there is no feedback from the sensor, this alarm appears. This alarm also shows if there is a communication error between the fan power card and the control card.

Check the alarm log for the report value associated with this warning.

If the report value is 2, there is a hardware problem with 1 of the fans. If the report value is 12, there is a communication problem between the fan power card and the control card.

Fan troubleshooting

- Cycle power to the drive and check that the fan operates briefly at start-up.
- Check for proper fan operation. Use *parameter group 43-** Unit Readouts* to show the speed of each fan.

Fan power card troubleshooting

- Check the wiring between the fan power card and the control card.
- Fan power card may need to be replaced.
- Control card may need to be replaced.

WARNING 24, External fan fault

The fan warning function is a protective function that checks if the fan is running/mounted. The fan warning can be disabled in *parameter 14-53 Fan Monitor ([0] Disabled)*.

A feedback sensor is mounted in the fan. If the fan is commanded to run and there is no feedback from the sensor, this alarm appears. This alarm also shows if there is

a communication error between the power card and the control card.

Check the alarm log for the report value associated with this warning.

If the report value is 1, there is a hardware problem with 1 of the fans. If the report value is 11, there is a communication problem between the power card and the control card.

Fan troubleshooting

- Cycle power to the drive and check that the fan operates briefly at start-up.
- Check for proper fan operation. Use *parameter group 43-** Unit Readouts* to show the speed of each fan.

Power card troubleshooting

- Check the wiring between the power card and the control card.
- Power card may need to be replaced.
- Control card may need to be replaced.

WARNING 25, Brake resistor short circuit

The brake resistor is monitored during operation. If a short circuit occurs, the brake function is disabled and the warning appears. The drive is still operational, but without the brake function.

Troubleshooting

- Remove the power to the drive and replace the brake resistor (refer to *parameter 2-15 Brake Check*).
- In parallel drive systems, check the brake parallel connections.

WARNING/ALARM 26, Brake resistor power limit

The power transmitted to the brake resistor is calculated as a mean value over the last 120 s of run-time. The calculation is based on the DC-link voltage and the brake resistor value set in *parameter 2-16 AC brake Max. Current*. The warning is active when the dissipated braking power is higher than 90% of the brake resistor power. If option [2] *Trip* is selected in *parameter 2-13 Brake Power Monitoring*, the drive trips when the dissipated braking power reaches 100%.

WARNING/ALARM 27, Brake chopper fault

The brake transistor is monitored during operation and if a short circuit occurs, the brake function is disabled and a warning is issued. The drive is still operational but, since the brake transistor has short-circuited, substantial power is transmitted to the brake resistor even if it is inactive.

WARNING

OVERHEATING RISK

A surge in power can cause the brake resistor to overheat and possibly catch fire. Failure to remove power to the drive and remove the brake resistor can cause equipment damage.

Troubleshooting

- Remove power to the drive.
- Remove the brake resistor.
- Troubleshoot the short circuit.

WARNING/ALARM 28, Brake check failed

The brake resistor is not connected or not working.

Troubleshooting

- Check *parameter 2-15 Brake Check*.

ALARM 29, Heat sink temp

The maximum temperature of the heat sink has been exceeded. The temperature fault does not reset until the temperature drops below a defined heat sink temperature. The trip and reset points are different based on the drive power size.

Troubleshooting

Check for the following conditions:

- Ambient temperature too high.
- Motor cable too long.
- Incorrect airflow clearance above and below the drive.
- Blocked airflow around the drive.
- Damaged heat sink fan.
- Dirty heat sink.

For drives in enclosure sizes D and E, this alarm is based on the temperature measured by the heat sink sensor mounted inside the IGBT modules.

Troubleshooting

- Check fan resistance.
- Check soft charge fuses.
- Check IGBT thermal.

ALARM 30, Motor phase U missing

Motor phase U between the drive and the motor is missing.

⚠ WARNING**HIGH VOLTAGE**

Drives contain high voltage when connected to AC mains input, DC supply, or load sharing. Failure to perform installation, start-up, and maintenance by qualified personnel can result in death or serious injury.

- Only qualified personnel must perform installation, start-up, and maintenance.
- Before performing any service or repair work, use an appropriate voltage measuring device to make sure that there is no remaining voltage on the drive.

Troubleshooting

- Remove the power from the drive and check motor phase U.

ALARM 31, Motor phase V missing

Motor phase V between the drive and the motor is missing.

⚠ WARNING**HIGH VOLTAGE**

Drives contain high voltage when connected to AC mains input, DC supply, or load sharing. Failure to perform installation, start-up, and maintenance by qualified personnel can result in death or serious injury.

- Only qualified personnel must perform installation, start-up, and maintenance.
- Before performing any service or repair work, use an appropriate voltage measuring device to make sure that there is no remaining voltage on the drive.

Troubleshooting

- Remove the power from the drive and check motor phase V.

ALARM 32, Motor phase W missing

Motor phase W between the drive and the motor is missing.

⚠ WARNING**HIGH VOLTAGE**

Drives contain high voltage when connected to AC mains input, DC supply, or load sharing. Failure to perform installation, start-up, and maintenance by qualified personnel can result in death or serious injury.

- Only qualified personnel must perform installation, start-up, and maintenance.
- Before performing any service or repair work, use an appropriate voltage measuring device to make sure that there is no remaining voltage on the drive.

Troubleshooting

- Remove the power from the drive and check motor phase W.

ALARM 33, Inrush fault

Too many power-ups have occurred within a short time period.

Troubleshooting

- Let the unit cool to operating temperature.
- Check potential DC-link fault to ground.

WARNING/ALARM 34, Fieldbus communication fault

The fieldbus on the communication option card is not working.

WARNING/ALARM 35, Option fault

An option alarm is received. The alarm is option-specific. The most likely cause is a power-up or a communication fault.

WARNING/ALARM 36, Mains failure

This warning/alarm is only active if the supply voltage to the drive system is lost and *parameter 14-10 Mains Failure* is not set to option [0] *No Function*.

- Check the fuses to the drive system and the mains supply to the unit.
- Check that mains voltage conforms to product specifications.
- Check that the following conditions are not present:
Alarm 307, Excessive THD(V), alarm 321, Voltage imbalance, warning 417, Mains undervoltage, or warning 418, Mains overvoltage is reported if any of the listed conditions are true:
 - The 3-phase voltage magnitude drops below 25% of the nominal mains voltage.
 - Any single-phase voltage exceeds 10% of the nominal mains voltage.
 - Percent of phase or magnitude imbalance exceeds 8%.
 - Voltage THD exceeds 10%.

ALARM 37, Phase imbalance

There is a current imbalance between the power units.

ALARM 38, Internal fault

When an internal fault occurs, a code number defined in *Table 6.6* is shown.

Troubleshooting

- Cycle power.
- Check that the option is properly installed.
- Check for loose or missing wiring.

It may be necessary to contact the Danfoss supplier or service department. Note the code number for further troubleshooting directions.

Number	Text
0	The serial port cannot be initialized. Contact the Danfoss supplier or Danfoss Service Department.
256–259, 266, 268	The power EEPROM data is defective or too old. Replace the power card.
512–519	Internal fault. Contact the Danfoss supplier or Danfoss Service Department.
783	Parameter value outside of minimum/maximum limits.
1024–1284	Internal fault. Contact the Danfoss supplier or Danfoss Service Department.
1299	The option SW in slot A is too old.
1300	The option SW in slot B is too old.
1301	The option SW in slot C0 is too old.
1302	The option SW in slot C1 is too old.
1315	The option SW in slot A is not supported (not allowed).

Number	Text
1316	The option SW in slot B is not supported (not allowed).
1317	The option SW in slot C0 is not supported (not allowed).
1318	The option SW in slot C1 is not supported (not allowed).
1360–2819	Internal fault. Contact the Danfoss supplier or Danfoss Service Department.
2561	Replace control card.
2820	LCP stack overflow.
2821	Serial port overflow.
2822	USB port overflow.
3072–5122	Parameter value is outside its limits.
5123	Option in slot A: Hardware incompatible with control board hardware.
5124	Option in slot B: Hardware incompatible with control board hardware.
5125	Option in slot C0: Hardware incompatible with control board hardware.
5126	Option in slot C1: Hardware incompatible with control board hardware.
5127	Illegal option combination (2 options of the same kind mounted, or encoder in E0 and resolver in E1 or similar).
5168	Safe stop/safe torque off was detected on a control card that does not have safe stop/safe torque off.
5376–65535	Internal fault. Contact the Danfoss supplier or Danfoss Service Department.

Table 6.6 Internal Fault Codes

ALARM 39, Heat sink sensor

No feedback from the heat sink temperature sensor.

The signal from the IGBT thermal sensor is not available on the power card.

Troubleshooting

- Check the ribbon cable between the power card and gate drive card.
- Check for a defective power card.
- Check for a defective gate drive card.

WARNING 40, Overload of digital output terminal 27

Check the load connected to terminal 27 or remove the short-circuit connection. Check *parameter 5-00 Digital I/O Mode* and *parameter 5-01 Terminal 27 Mode*.

WARNING 41, Overload of digital output terminal 29

Check the load connected to terminal 29 or remove the short-circuit connection. Also check *parameter 5-00 Digital I/O Mode* and *parameter 5-02 Terminal 29 Mode*.

WARNING 42, Overload of digital output on X30/6 or overload of digital output on X30/7

For terminal X30/6, check the load connected to terminal X30/6 or remove the short-circuit connection. Also check *parameter 5-32 Term X30/6 Digi Out (MCB 101)* (VLT® General Purpose I/O MCB 101).

For terminal X30/7, check the load connected to terminal X30/7 or remove the short-circuit connection. Check *parameter 5-33 Term X30/7 Digi Out (MCB 101)* (VLT® General Purpose I/O MCB 101).

ALARM 43, Ext. supply

VLT® Extended Relay Option MCB 113 is mounted without external 24 V DC. Either connect a 24 V DC external supply or specify that no external supply is used via *parameter 14-80 Option Supplied by External 24VDC, [0] No.* A change in *parameter 14-80 Option Supplied by External 24VDC* requires a power cycle.

ALARM 45, Earth fault 2

Ground fault.

Troubleshooting

- Check for proper grounding and loose connections.
- Check for proper wire size.
- Check the motor cables for short circuits or leakage currents.

ALARM 46, Power card supply

The supply on the power card is out of range.

There are 4 supplies generated by the switch mode power supply on the power card:

- 48 V.
- 24 V.
- 5 V.
- ± 18 V.

When powered with VLT® 24 V DC Supply MCB 107, only the 24 V and 5 V supplies are monitored. When powered with 3-phase mains voltage, all 4 supplies are monitored.

Troubleshooting

- Check for a defective power card.
- Check for a defective control card.
- Check for a defective option card.
- If a 24 V DC supply is used, verify proper supply power.
- Check D-sized drives for a defective heat sink fan, top fan, or door fan.
- Check E-sized drives for a defective mixing fan.

WARNING 47, 24 V supply low

The supply on the power card is out of range.

There are 4 supplies generated by the switch mode supply (SMPS) on the power card:

- 48 V.
- 24 V.
- 5 V.
- ± 18 V.

Troubleshooting

- Check for a defective power card.

WARNING 48, 1.8 V supply low

The 1.8 V DC supply used on the control card is outside of the allowable limits. The supply is measured on the control card.

Troubleshooting

- Check for a defective control card.
- If an option card is present, check for overvoltage.

WARNING 49, Speed limit

The warning is shown when the speed is outside of the specified range in *parameter 4-11 Motor Speed Low Limit [RPM]* and *parameter 4-13 Motor Speed High Limit [RPM]*. When the speed is below the specified limit in *parameter 1-86 Trip Speed Low [RPM]* (except when starting or stopping), the drive trips.

ALARM 50, AMA calibration failed

Contact the Danfoss supplier or Danfoss service department.

ALARM 51, AMA check U_{nom} and I_{nom}

The settings for motor voltage, motor current, and motor power are wrong.

Troubleshooting

- Check the settings in *parameters 1-20 to 1-25*.

ALARM 52, AMA low I_{nom}

The motor current is too low.

Troubleshooting

- Check the settings in *parameter 1-24 Motor Current*.

ALARM 53, AMA motor too big

The motor is too large for the AMA to operate.

ALARM 54, AMA motor too small

The motor is too small for the AMA to operate.

ALARM 55, AMA parameter out of range

The AMA cannot run because the parameter values of the motor are outside of the acceptable range.

ALARM 56, AMA interrupted by user

The AMA is manually interrupted.

ALARM 57, AMA internal fault

Try to restart the AMA. Repeated restarts can overheat the motor.

ALARM 58, AMA Internal fault

Contact the Danfoss supplier.

WARNING 59, Current limit

The current is higher than the value in *parameter 4-18 Current Limit*. Ensure that the motor data in *parameters 1-20 to 1-25* is set correctly. Increase the current limit if necessary. Ensure that the system can operate safely at a higher limit.

WARNING 60, External interlock

A digital input signal indicates a fault condition external to the drive. An external interlock has commanded the drive to trip. Clear the external fault condition. To resume normal operation, apply 24 V DC to the terminal programmed for external interlock, and reset the drive.

WARNING/ALARM 61, Feedback error

An error is detected between calculated speed and speed measurement from feedback device.

Troubleshooting

- Check the settings for warning/alarm/disabling in *parameter 4-30 Motor Feedback Loss Function*.
- Set the tolerable error in *parameter 4-31 Motor Feedback Speed Error*.
- Set the tolerable feedback loss time in *parameter 4-32 Motor Feedback Loss Timeout*.

WARNING 62, Output frequency at maximum limit

If the output frequency reaches the value set in *parameter 4-19 Max Output Frequency*, the drive issues a warning. The warning ceases when the output drops below the maximum limit. If the drive is unable to limit the frequency, it trips and issues an alarm. The latter may happen in the flux mode if the drive loses control of the motor.

Troubleshooting

- Check the application for possible causes.
- Increase the output frequency limit. Ensure that the system can operate safely at a higher output frequency.

ALARM 63, Mechanical brake low

The actual motor current has not exceeded the release brake current within the start delay time window.

WARNING 64, Voltage limit

The combination of load and speed requires a motor voltage higher than the actual DC-link voltage.

WARNING/ALARM 65, Control card over temperature

The cutout temperature of the control card is 85 °C (185 °F).

Troubleshooting

- Check that the ambient operating temperature is within the limits.
- Check for clogged filters.
- Check the fan operation.
- Check the control card.

WARNING 66, Heat sink temperature low

The drive is too cold to operate. This warning is based on the temperature sensor in the IGBT module. Increase the ambient temperature of the unit. Also, a trickle amount of current can be supplied to the drive whenever the motor is stopped by setting *parameter 2-00 DC Hold/Preheat Current* to 5% and *parameter 1-80 Function at Stop*.

ALARM 67, Option module configuration has changed

One or more options have either been added or removed since the last power-down. Check that the configuration change is intentional and reset the unit.

ALARM 68, Safe Stop activated

Safe Torque Off (STO) has been activated. To resume normal operation, apply 24 V DC to terminal 37, then send a reset signal (via bus, digital I/O, or by pressing [Reset]).

ALARM 69, Power card temperature

The temperature sensor on the power card is either too hot or too cold.

Troubleshooting

- Check that the ambient operating temperature is within limits.
- Check for clogged filters.
- Check fan operation.
- Check the power card.

ALARM 70, Illegal FC configuration

The control card and power card are incompatible. To check compatibility, contact the Danfoss supplier with the type code from the unit nameplate and the part numbers of the cards.

WARNING/ALARM 71, PTC 1 Safe Stop

Safe Torque Off (STO) has been activated from the VLT® PTC Thermistor Card MCB 112 because the motor is too warm. Once the motor cools and the digital input from the MCB 112 is deactivated, normal operation can resume when the MCB 112 applies 24 V DC to terminal 37 again. When the motor is ready for normal operation, a reset signal is sent (via serial communication, digital I/O, or by pressing [Reset] on the LCP). If automatic restart is enabled, the motor can start when the fault is cleared.

ALARM 72, Dangerous failure

Safe Torque Off (STO) with trip lock. Unexpected signal levels on safe torque off and digital input from the VLT® PTC Thermistor Card MCB 112.

WARNING 73, Safe Stop auto restart

Safe Torque Off (STO) activated. With automatic restart enabled, the motor can start when the fault is cleared.

ALARM 74, PTC Thermistor

Alarm related to VLT® PTC Thermistor Card MCB 112. The PTC is not working.

ALARM 75, Illegal profile sel.

Do not write the parameter value while the motor is running. Stop the motor before writing the MCO profile to *parameter 8-10 Control Profile*.

WARNING 76, Power unit setup

The required number of power units does not match the detected number of active power units. If the power card connection is lost, the unit also triggers this warning.

Troubleshooting

- Confirm that the spare part and its power card are the correct part number.
- Ensure that the 44-pin cables between the MDCIC and power cards are mounted properly.

WARNING 77, Reduced power mode

This alarm applies to only multi-drive systems. The system is operating in reduced power mode (fewer than the allowed number of drive modules). This warning is generated on power cycle when the system is set to run with fewer drive modules and remains on.

ALARM 78, Tracking error

The difference between setpoint value and actual value exceeds the value in *parameter 4-35 Tracking Error*.

Troubleshooting

- Disable the function or select an alarm/warning in *parameter 4-34 Tracking Error Function*.
- Investigate the mechanics around the load and motor. Check feedback connections from motor encoder to drive.
- Select motor feedback function in *parameter 4-30 Motor Feedback Loss Function*.
- Adjust the tracking error band in *parameter 4-35 Tracking Error* and *parameter 4-37 Tracking Error Ramping*.

ALARM 79, Illegal power section configuration

The scaling card has an incorrect part number or is not installed. Also, the MK101 connector on the power card could not be installed.

ALARM 80, Drive initialised to default value

Parameter settings are initialized to default settings after a manual reset. To clear the alarm, reset the unit.

ALARM 81, CSIV corrupt

CSIV file has syntax errors.

ALARM 82, CSIV parameter error

CSIV failed to initialize a parameter.

ALARM 83, Illegal option combination

The mounted options are incompatible.

ALARM 84, No safety option

The safety option was removed without applying a general reset. Reconnect the safety option.

ALARM 85, Dang fail PB

PROFIBUS/PROFIsafe error.

ALARM 88, Option detection

A change in the option layout is detected. *Parameter 14-89 Option Detection* is set to [0] *Frozen configuration* and the option layout has been changed.

- To apply the change, enable option layout changes in *parameter 14-89 Option Detection*.
- Alternatively, restore the correct option configuration.

WARNING 89, Mechanical brake sliding

The hoist brake monitor detects a motor speed exceeding 10 RPM.

ALARM 90, Feedback monitor

Check the connection to encoder/resolver option and, if necessary, replace VLT® Encoder Input MCB 102 or VLT® Resolver Input MCB 103.

ALARM 91, Analog input 54 wrong settings

Set switch S202 in position OFF (voltage input) when a KTY sensor is connected to analog input terminal 54.

ALARM 92, No flow

A no-flow condition is detected in the system. *Parameter 22-23 No-Flow Function* is set for alarm.

Troubleshooting

- Troubleshoot the system and reset the drive after clearing the fault.

ALARM 93, Dry pump

A no-flow condition in the system with the drive operating at high speed can indicate a dry pump. *Parameter 22-26 Dry Pump Function* is set for alarm.

Troubleshooting

- Troubleshoot the system and reset the drive after clearing the fault.

ALARM 94, End of curve

The feedback is lower than the setpoint. This condition can indicate leakage in the system. *Parameter 22-50 End of Curve Function* is set for alarm.

Troubleshooting

- Troubleshoot the system and reset the drive after clearing the fault.

ALARM 95, Broken belt

Torque is below the torque level set for no load, indicating a broken belt. *Parameter 22-60 Broken Belt Function* is set for alarm.

Troubleshooting

- Troubleshoot the system and reset the drive after clearing the fault.

ALARM 96, Start delayed

The motor start has been delayed due to short-cycle protection. *Parameter 22-76 Interval between Starts* is enabled.

Troubleshooting

- Troubleshoot the system and reset the drive after clearing the fault.

WARNING 97, Stop delayed

Stopping the motor has been delayed because the motor has been running for less than the minimum time specified in *parameter 22-77 Minimum Run Time*.

WARNING 98, Clock fault

Time is not set, or the RTC clock has failed. Reset the clock in *parameter 0-70 Date and Time*.

ALARM 99, Locked rotor

The rotor is blocked.

WARNING/ALARM 104, Mixing fan fault

The fan is not operating. The fan monitor checks that the fan is spinning at power-up or whenever the mixing fan is turned on. The mixing-fan fault can be configured as a warning or an alarm trip in *parameter 14-53 Fan Monitor*.

Troubleshooting

- Cycle power to the drive to determine if the warning/alarm returns.

WARNING/ALARM 122, Mot. rotat. unexp.

The drive performs a function that requires the motor to be at standstill, for example DC hold for PM motors.

ALARM 144, Inrush Supply

A supply voltage on the inrush card is out of range. See the bit field result report value for more details.

- Bit 2: Vcc high.
- Bit 3: Vcc low.
- Bit 4: Vdd high.
- Bit 5: Vdd low.

ALARM 145, External SCR disable

The alarm indicates a series DC-link capacitor voltage imbalance.

WARNING/ALARM 146, Mains voltage

Mains voltage is outside valid operating range. The following report values provide more details.

- Voltage too low: 0=R-S, 1=S-T, 2=T-R
- Voltage too high: 3=R-S, 4=S-T, 5=T-R

WARNING/ALARM 147, Mains frequency

Mains frequency is outside valid operating range. Report value provides more details.

- 0: frequency too low.
- 1: frequency too high.

WARNING/ALARM 148, System temp

One or more of the system temperature measurements is too high.

WARNING 163, ATEX ETR cur.lim.warning

The drive has run above the characteristic curve for more than 50 s. The warning is activated at 83% and deactivated at 65% of the allowed thermal overload.

ALARM 164, ATEX ETR cur.lim.alarm

Operating above the characteristic curve for more than 60 s within a period of 600 s activates the alarm, and the drive trips.

WARNING 165, ATEX ETR freq.lim.warning

The drive is running for more than 50 s below the allowed minimum frequency (*parameter 1-98 ATEX ETR interpol. points freq.*).

ALARM 166, ATEX ETR freq.lim.alarm

The drive has operated for more than 60 s (in a period of 600 s) below the allowed minimum frequency (*parameter 1-98 ATEX ETR interpol. points freq.*).

WARNING 200, Fire mode

The drive is operating in fire mode. The warning clears when fire mode is removed. Refer to the fire mode data in the alarm log.

WARNING 201, Fire mode was active

The drive has entered fire mode. Cycle power to the unit to remove the warning. Refer to the fire mode data in the alarm log.

WARNING 202, Fire mode limits exceeded

While operating in fire mode, 1 or more alarm conditions that would normally trip the unit have been ignored. Operating in this condition voids unit warranty. Cycle power to the unit to remove the warning. Refer to the fire mode data in the alarm log.

WARNING 203, Missing motor

With a drive operating multi-motors, an underload condition was detected. This condition can indicate a missing motor. Inspect the system for proper operation.

WARNING 204, Locked rotor

With a drive operating multi-motors, an overload condition was detected. This condition can indicate a locked rotor. Inspect the motor for proper operation.

WARNING 219, Compressor interlock

At least 1 compressor is inversely interlocked via a digital input. The interlocked compressors can be viewed in *parameter 25-87 Inverse Interlock*.

ALARM 243, Brake IGBT

This alarm is only for multi-drive systems. It is equivalent to *alarm 27, Brake chopper fault*. The report value in the alarm log indicates which drive module generated the alarm. This IGBT fault can be caused by any of the following:

- The DC fuse is blown.
- The brake jumper is not in position.
- The Klixon switch opened due to an overtemperature condition in the brake resistor.

The report value in the alarm log indicates which drive module generated the alarm:

- 1 = Left drive module.
- 2 = Second drive module from left.
- 3 = Third drive module from left (in 4-module module systems).
- 4 = Fourth drive module from left (in 4-module module systems).

ALARM 244, Heat sink temperature

The maximum temperature of the heat sink has been exceeded. The temperature fault cannot reset until the temperature drops below a defined heat sink temperature. The trip and reset points are different based on the power size. This alarm is equivalent to *alarm 29, Heat Sink Temp.*

Troubleshooting

Check for the following conditions:

- Ambient temperature too high.
- Motor cables too long.
- Incorrect airflow clearance above or below the AC drive.
- Blocked airflow around the unit.
- Damaged heat sink fan.
- Dirty heat sink.

ALARM 245, Heat sink sensor

No feedback from the heat sink temperature sensor. The signal from the IGBT thermal sensor is not available on the power card. This alarm is equivalent to *alarm 39, Heat sink sensor*. The report value in the alarm log indicates which drive module generated the alarm:

- 1 = Left drive module.
- 2 = Second drive module from left.
- 3 = Third drive module from left (in 4-module module systems).
- 4 = Fourth drive module from left (in 4-module module systems).

Troubleshooting

Check the following:

- Power card.
- Gate drive card.
- Ribbon cable between the power card and the gate drive card.

ALARM 246, Power card supply

This alarm is only for multi-drive systems. It is equivalent to *alarm 46, Power card supply*. The report value in the alarm log indicates which drive module generated the alarm:

- 1 = Left drive module.
- 2 = Second drive module from left.
- 3 = Third drive module from left (in 4-module module systems).
- 4 = Fourth drive module from left (in 4-module module systems).

ALARM 247, Power card temperature

This alarm is only for multi-drive systems. It is equivalent to *alarm 69, Power card temperature*. The report value in the alarm log indicates which drive module generated the alarm:

- 1 = Left drive module.
- 2 = Second drive module from left.
- 3 = Third drive module from left (in 4-module module systems).
- 4 = Fourth drive module from left (in 4-module module systems).

ALARM 248, Illegal power section configuration

This alarm is only for multi-drive systems. It is equivalent to *alarm 79, Illegal power section configuration*. The report value in the alarm log indicates which drive module generated the alarm:

- 1 = Left drive module.
- 2 = Second drive module from left.
- 3 = Third drive module from left (in 4-module module systems).
- 4 = Fourth drive module from left (in 4-module module systems).

Troubleshooting

Check the following:

- The current scaling cards on the MDCIC.

WARNING 250, New spare part

The power or switch mode supply has been exchanged. Restore the drive type code in the EEPROM. Select the correct type code in *parameter 14-23 Typecode Setting* according to the label on the drive. Remember to select Save to EEPROM at the end.

WARNING 251, New type code

The power card or other components have been replaced and the type code has been changed.

Troubleshooting

- Reset to remove the warning and to resume normal operation.

ALARM 421, Temperature fault

A fault caused by the on-board temperature sensor is detected on the fan power card.

Troubleshooting

- Check wiring.
- Check sensor.
- Replace fan power card.

ALARM 422, Communication fault

A fan power card (FPC) communication failure is detected. The alarm report value indicates which card generated the fault, and whether the fault is upstream or downstream. A value <100 indicates upstream card communication failure. A value >100 indicates a downstream card communication failure. A report value of 255 indicates that the control card generated the fault.

Troubleshooting:

- Check the wiring between the cards that generated the fault. It could be either 2 FPCs or the control card and the first FPC.
- Replace the faulty FPC.
- Replace the faulty control card.

ALARM 423, FPC updating

The alarm is generated when the fan power card reports it has an invalid PUD. The control card attempts to update the PUD. A subsequent alarm can result depending on the update. See A424 and A425.

ALARM 424, FPC update successful

This alarm is generated when the control card has successfully updated the fan power card PUD. The drive must be reset to stop the alarm.

ALARM 425, FPC update failure

This alarm is generated after the control card failed to update the fan power card PUD.

Troubleshooting

- Check the fan power card wiring.
- Replace fan power card.
- Contact supplier.

ALARM 426, FPC config

The number of found fan power cards does not match the number of configured fan power cards. See *parameter group 15-6* Option Ident* for the number of configured fan power cards.

Troubleshooting

- Check fan power card wiring.
- Replace fan power card.

ALARM 427, FPC supply

Supply voltage fault (5 V, 24 V, or 48 V) on fan power card is detected.

Troubleshooting

- Check fan power card wiring.
- Replace fan power card.

7 Drive and Motor Applications

7.1 Torque Limit, Current Limit, and Unstable Motor Operation

Excessive loading of the drive can result in warning or tripping on torque limit, overcurrent, or inverter time. This situation is not a concern if the drive is properly sized for the application and intermittent load conditions cause an occasional trip. However, nuisance or unexplained occurrences can be the result of improperly set parameters. The following parameters are important in matching the drive to the motor for optimum operation.

- *Parameter 1-00 Configuration Mode* sets the drive for open or closed-loop operation, or torque mode operation.
- *Parameter 1-03 Torque Characteristics* sets the mode in which the drive operates.
- *Parameters 1-20 to 1-29* match the drive to the motor and adapt to the motor characteristics.
- *Parameter 4-16 Torque Limit Motor Mode*, *parameter 4-17 Torque Limit Generator Mode*, and *parameter 14-25 Trip Delay at Torque Limit* set the torque control features of the drive for the application.

Parameter 1-00 Configuration Mode

This parameter sets the drive for open loop, closed loop, or torque mode operation. In a closed-loop configuration, a feedback signal controls the drive speed. The settings for the PID controller play a key role for stable operation in closed loop, as described in the operating instructions. In open loop, the drive calculates the torque requirement based on current measurements of the motor.

Parameter 1-03 Torque Characteristics

This parameter sets the drive for constant or variable torque operation. It is imperative that the correct torque characteristic is selected. For example, if the load type is constant torque, such as a conveyor, and [1] *Variable torque* is selected, the drive can have difficulty starting the load. Consult Danfoss if uncertain about the torque characteristics of an application.

Parameter 1-20 Motor Power [kW] and parameter 1-25 Motor Nominal Speed

These parameters configure the drive for the connected motor. These parameters are motor power, voltage, frequency, current, and nominal motor speed. Accurate setting of these parameters is important. Enter the required motor data as listed on the motor nameplate. For proper load control, the drive relies on this information for calculating the output waveform in response to the application demands.

Parameter 1-29 Automatic Motor Adaptation (AMA)

This parameter activates the automatic motor adaptation (AMA) function. When AMA is performed, the drive measures the electrical resistance of the motor stator windings (R1). *Parameter 1-31 Rotor Resistance (Rr)* – *parameter 1-35 Main Reactance (Xh)* must be requested from the motor manufacturer the optimal performance of the drive data. To set *parameter 1-31 Rotor Resistance (Rr)* – *parameter 1-35 Main Reactance (Xh)*, use the values supplied by the motor manufacturer or leave at the factory default values.

Never adjust these parameters to random values even though it seems to improve operation. Such adjustments can result in unpredictable operation under changing conditions.

Parameter 4-17 Torque Limit Generator Mode and parameter 4-16 Torque Limit Motor Mode

These parameters set the limit for the drive torque. The factory setting is 160% for VLT® AutomationDrive FC 302 and 110% for VLT® HVAC Drive FC 102/VLT® AQUA Drive FC 202 and varies with motor power setting. For example, a drive programmed to operate a smaller motor yields a higher torque limit value than when programmed for a larger motor. It is important that this value is not set too low for the requirements of the application. Sometimes, it can be desirable to have a torque limit set at a lower value. This offers protection for the application as the drive limits the torque. It can, however, require higher torque at initial start-up, which can cause nuisance tripping.

Parameter 14-25 Trip Delay at Torque Limit

This parameter works with torque limit. This parameter selects the period in which the drive operates in torque limit before a trip. The factory default value is Off. This setting means that the drive does not trip on torque limit, although the unit can still trip from an overload condition. Built into the drive is an internal inverter thermal protection circuit. This circuit monitors the output load on the inverter. If the load exceeds 100% of the continuous rating of the drive, a timer is activated. If the load remains excessive long enough, the drive trips on inverter time. Adjustments cannot be made to alter this circuit. Improper parameter settings effecting load current can result in premature trips of this type. The timer can be shown on the LCP.

7.1.1 Overvoltage Trips

This trip occurs when the DC bus voltage reaches its DC bus alarm voltage high. Before tripping, the drive shows a high-voltage warning. Usually, the cause of an overvoltage condition is fast deceleration ramps relative to the inertia of the load. During deceleration of the load, inertia of the system acts to sustain the running speed. Once the motor frequency drops below the running speed, the load begins overtaking the motor. The motor becomes a generator and starts returning energy to the drive. This process is called regenerative energy. Regen occurs when the speed of the load is greater than the commanded speed. The diodes in the IGBT modules rectify this return voltage, which raises the DC bus. If the amount of returned voltage is too high, the drive trips.

Ways to avoid overvoltage trips

- Reduce the deceleration rate. The drive can only decelerate the load slightly faster than it would take for the load to naturally coast to a stop.
- Allow the overvoltage control circuit to take care of the deceleration ramp. When enabled, the overvoltage control circuit regulates deceleration at a rate that maintains the DC bus voltage at a level that keeps the unit from tripping. Overvoltage control corrects minor, but not major discrepancies between ramp rates. For example, if a deceleration ramp of 100 s is required, and the ramp rate is set at 70 s, the overvoltage control corrects it. However, with the same inertia, if the ramp is set at a larger difference, such as 3 s, overvoltage control engages initially, and then disengages, allowing the drive to trip. This trip is done deliberately to avoid confusion about the operation of the drive.
- Control regenerated energy with a dynamic brake. If the DC bus level becomes too high, the drive switches the resistor across the DC bus. The unwanted energy is dissipated into the external resistor bank mounted outside of the drive. This process increases deceleration rate.

Less often, the load causes an overvoltage condition while running at speed. When this condition occurs, the dynamic brake option or the overvoltage control circuit can be used. For example, if the speed of the load is greater than the commanded speed, the overvoltage circuit increases the frequency to match. The same restriction on the amount of influence applies.

The drive adds about 10% to the base speed before a trip occurs. Otherwise, the speed could continue to rise to potentially unsafe levels.

7.1.2 Mains Phase Loss Trips

Mains phase loss trips in D-sized drives

D-sized drives monitor phase loss by monitoring the amount of ripple voltage on the DC bus. Ripple voltage on the DC bus is a product of a phase loss, and can cause overheating in the DC bus capacitors and DC coil. If the ripple voltage on the DC bus is unchecked, the lifetime of the capacitors is reduced significantly.

When the input voltage becomes unbalanced or a phase disappears completely, the ripple voltage increases. This increase causes the drive to trip and issue *alarm 4, Mains Phase Loss*. In addition to missing phase voltage, a line disturbance or imbalance can increase bus ripple.

Mains phase loss trips in E-sized drives

In E-sized drives, mains imbalance is directly measured by the inrush card. If the voltage imbalance is greater than 10%, then the drive is considered to be in single-phase mode. Once a predetermined motor power is exceeded, the drive trips. If communication with the inrush card is lost, the drive reverts to the phase loss monitoring of the D-sized drive.

The following parameters show the input voltage:

- *Parameter 18-70 Mains Voltage [0]* shows the average of the 3 input phases.
- *Parameter 18-70 Mains Voltage [1]* shows the voltage between R and S phases.
- *Parameter 18-70 Mains Voltage [2]* shows the voltage between S and T phases.
- *Parameter 18-70 Mains Voltage [3]* shows the voltage between T and U phases.
- *Parameter 18-72 Mains Imbalance* measurement of the mains imbalance.

Possible sources of disturbance

Loads affecting the form factor of the AC waveform cause line disturbances. For example, notching or defective transformers can cause disturbances.

Mains imbalances that exceed 3% cause sufficient DC bus ripple to initiate a trip. In 12-pulse systems, the allowed DC ripple is smaller than the ripple allowed in 6-pulse systems.

Other causes of increased ripple voltage on the DC bus include:

- Output disturbance.
- Missing or lower than normal output voltage on 1 phase.

Checks

When a mains imbalance trip occurs, check both the input and output voltage of the drive. Significant imbalance of supply voltage or phase loss is detectable with a voltmeter. View line disturbances through an oscilloscope.

Conduct tests for:

- Input imbalance of supply voltage
- Input waveform
- Output imbalance of supply voltage

Refer to *chapter 8.5.2 Input Voltage Test*, *chapter 8.5.6 Input Imbalance of Supply Voltage Test*, and *chapter 8.5.9 Output Imbalance of Motor Voltage and Current*.

In 12-pulse systems, check the input imbalance between the 2 secondary winding voltages.

7.1.3 Control Logic Problems

Problems with control logic can often be difficult to diagnose since there is usually no associated fault indication. Typically, the drive does not respond to a given command.

To obtain an output, provide these basic commands to the drive:

- Start command: To execute.
- Reference or speed command: To identify the speed of execution.

The drives are designed to accept various signals. First determine which of these signals the drive is receiving:

- Digital inputs (18, 19, 27, 29, 32, 33)
- Analog outputs (42)
- 10 V output
- Analog inputs (53, 54)
- Serial communication bus (68, 69)

The presence of a correct reading indicates that the microprocessor of the drive has detected the signal. Refer to *chapter 4.9 Shielded Cable Grounding* and *chapter 8.5.14 Input Terminal Signal Tests*.

This data can also be read in *parameter group 16-6* Inputs & Outputs*.

If there is no correct indication, check that the signal is present at the input terminals of the drive. Refer to *chapter 8.5.14 Input Terminal Signal Tests*.

If the signal is present at the terminal, the control card is defective and must be replaced. If the signal is not present, the problem is external to the drive. Check the circuitry providing the signal along with its associated wiring.

7.1.4 Programming Problems

Difficulty with operation of the drive can be a result of improper programming of the drive parameters.

The 3 areas where programming errors can affect drive and motor operation are:

- Motor settings.
- References and limits.
- I/O configuration.

Refer to *chapter 4.6 Drive Inputs and Outputs*.

Set up the drive correctly for the motor or motors connected to it. *Parameter 1-20 Motor Power [kW]* – *parameter 1-25 Motor Nominal Speed* must have data from the motor nameplate entered into the drive. This data enables the drive processor to match the drive to the power characteristics of the motor. The most common result of inaccurate motor data is that the motor draws higher than normal amounts of current to perform the task. In such cases, setting the correct values to these parameters and performing the AMA function usually solves the problem.

Any references or limits set incorrectly result in poor drive performance. For instance, if maximum reference is set too low, the motor is unable to reach full speed. Set these parameters according to the requirements of the particular installation. References are set in *parameter group 3-0* Reference/Ramps*.

Incorrectly set I/O configuration usually results in the drive not responding to the function as commanded. Remember that for every control terminal input or output, there are corresponding parameter settings. These settings determine how the drive responds to an input signal or the type of signal present at that output. Utilizing an I/O function involves a 2-step process. First, wire the I/O terminal properly, and then set the corresponding parameter. Control terminals are programmed in *parameter groups 5-0* Digital I/O Mode* and *6-0* Analog I/O Mode*.

7.1.5 Motor Load Problems

The motor or motor wiring can develop a phase-to-phase or phase-to-ground short circuit resulting in an alarm indication. Check whether the problem is in the motor wiring or the motor itself.

A motor with unbalanced or asymmetrical impedances on all 3 phases can result in rough operation or unbalanced output currents. For measurements, use a clamp-on style ammeter to determine whether the current is balanced on

the 3 output phases. Refer to *chapter 4.6 Drive Inputs and Outputs*.

Usually, a current limit warning indicates an incorrect mechanical load. If possible, disconnect the motor from the load to determine if the load is incorrect.

Often, the indications of motor problems are similar to the problems of a defective drive. To determine whether the problem is with the drive, disconnect the motor from the motor terminals. Perform the test in *chapter 8.5.9 Output Imbalance of Motor Voltage and Current*. If the 3 voltage measurements are balanced, the drive functions correctly.

If the voltage measurements are not balanced, the drive malfunctions. Typically, 1 or more output IGBTs do not function correctly. This problem can be a result of a defective IGBT or gate signal.

7.2 Internal Drive Problems

To identify most problems related to failed power components, perform a visual inspection and the static tests as described in *chapter 8.4 Static Test Procedures*. However, the following problems must be diagnosed in a different manner.

7.2.1 Overtemperature Faults

When an overtemperature indication occurs, determine whether this condition exists within the drive or whether the thermal sensor is defective. If an overtemperature condition is present in the drive, the outside of the unit is warm. If the exterior is not warm, check the temperature sensor with an ohmmeter.

7.2.2 Current Sensor Faults

An overcurrent alarm that cannot be reset, even with the motor cables disconnected, sometimes indicates current sensor failure. The drive experiences frequent false ground fault trips due to the DC offset failure mode of the sensors.

An explanation of the internal composition of a Hall-effect type current sensor helps to explain these faults. Included inside the device is an op-amp to amplify the signal to usable levels in the receiving circuitry. The output at 0 input level (0 A flow being measured) is 0 V, exactly halfway between the plus and minus supply voltages. A tolerance of ± 15 mV is acceptable. In a 3-phase system that operates correctly, the sum of the 3 output currents is always 0.

When the sensor becomes defective, the output voltage level varies by more than the 15 mV. The defective current sensor in that phase indicates current flow when there is

none. This condition results in the sum of the 3 output currents being a value other than 0. If the deviation from 0 (current amplitude) approaches a specific level, the drive assumes a ground fault and issues an alarm.

To determine whether a current sensor is defective, disconnect the motor from the drive and observe the current in the drive display. With the motor disconnected, the current must be 0. A drive with a defective current sensor indicates some current flow. Because the current sensors for the drives with higher power ratings have less resolution, an indication of a fraction of 1 A is tolerable. However, that value must be considerably lower than 1 A. If the display shows more than 1 A of current, the current sensor is defective.

To determine which current sensor is defective, measure the voltage offset at zero current for each current sensor. Refer to *chapter 8.5.12 Current Sensors Test*.

7.3 Electromagnetic Compatibility

The following is an overview of general signal and power wiring considerations when addressing the electromagnetic compatibility (EMC) concerns for typical commercial and industrial equipment. High-frequency RF emissions and immunity are discussed. Compliance to national and European CE EMC directives are required.

7.3.1 Effects of EMI

While electromagnetic interference (EMI) disturbances to the operation of the unit are uncommon, the following detrimental EMI effects can be seen:

- Motor speed fluctuations
- Serial communication transmission errors
- Drive CPU exception faults
- Unexplained drive trips

A disturbance resulting from other nearby equipment is more common. Generally, other industrial control equipment has a high level of EMI immunity. However, non-industrial, commercial, and consumer equipment is often susceptible to lower levels of EMI.

Detrimental effects to these systems can include the following:

- Pressure/flow/temperature signal transmitter signal distortion or aberrant behavior
- Radio and TV interference
- Telephone interference
- Computer network data loss
- Digital control system faults

7.3.2 EMI Signal and Power Wiring

The following is an overview of general signal and power wiring considerations related to electromagnetic compatibility (EMC) for typical commercial and industrial equipment. Only certain high frequency phenomena (such as RF emissions, RF immunity) are discussed. Low-frequency phenomena (such as harmonics, mains voltage imbalance, notching) are not covered. Special installations or compliance to the European CE EMC directives requires strict adherence to relevant standards and are not discussed here.

Power wiring considerations for optional busbar kits used in parallel drive systems are not discussed here. See the *Busbar Kit Instructions* for more information about power wiring.

7

7.3.3 Sources of EMI

D-sized and E-sized drives (*Illustration 7.1*) use IGBTs to create the pulse-width modulated (PWM) output waveform necessary for accurate motor control. These IGBTs rapidly switch the fixed DC bus voltage creating a variable frequency and a variable voltage PWM waveform. This high rate of voltage change [dU/dt] is the primary source of generated EMI of the drives.

The high rate of voltage change caused by the IGBT switching creates high-frequency EMI.

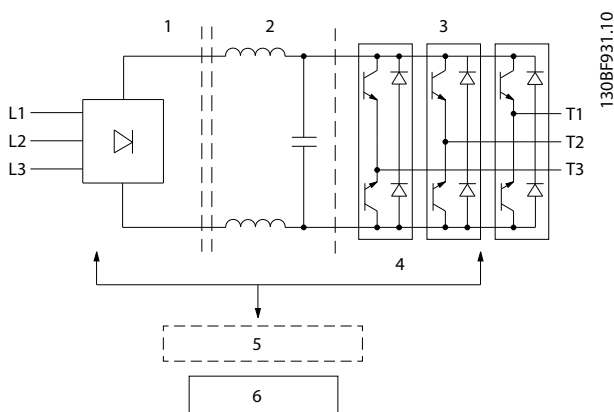

1	Rectifier (SCR/diodes)
2	DC link (DC bus)
3	Inverter (IGBTs)
4	Power section
5	Logic-to-power interface
6	Control logic

Illustration 7.1 6-pulse Functionality Diagram

7.3.4 EMI Propagation

Drive-generated EMI is both conducted to the mains and radiated to nearby conductors. Refer to *Illustration 7.2*. Stray capacitance between the motor conductors, equipment ground, and other nearby conductors results in induced high-frequency currents.

High ground circuit impedance at high frequencies results in an instant voltage at points reputed to be at ground potential. This voltage appears throughout a system as a common mode signal that interferes with control signals. Theoretically, these currents return to the DC bus via the ground circuit and a high-frequency (HF) bypass network within the drive itself. However, imperfections in the drive grounding or the equipment ground system can cause some of the currents to travel out to the power network.

Unprotected or poorly routed signal conductors located close to or in parallel to motor and mains conductors are susceptible to EMI. Signal conductors are especially vulnerable when they are run parallel to the power conductors for any distance. EMI coupled into these conductors can affect either the drive or the interconnected control device. Refer to *Illustration 7.4*.

These currents tend to travel back to the drive. However, imperfections in the system cause some current to flow in undesirable paths and expose other locations to EMI. When the mains conductors are close to the motor cables, high-frequency currents can be coupled into the mains supply.

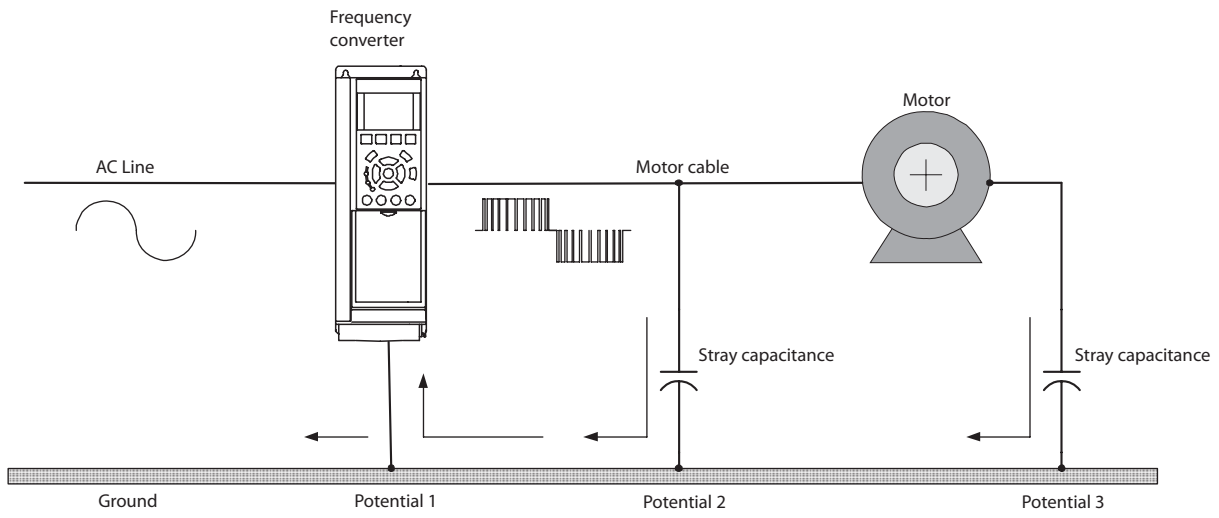

130BX138.11

Illustration 7.2 Ground Currents

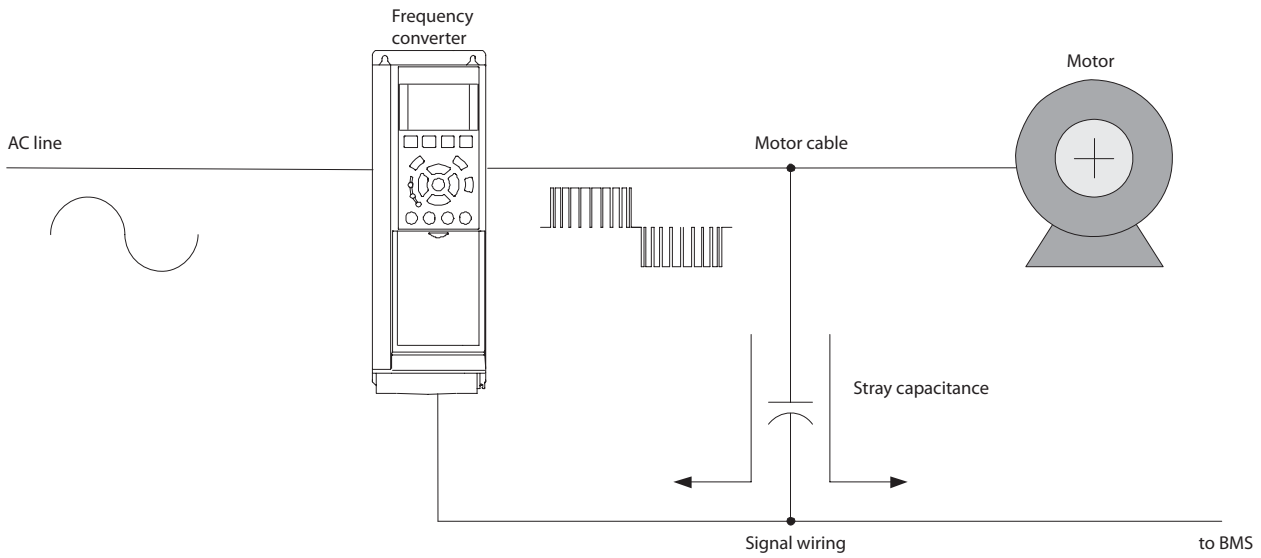

130BX139.12

Illustration 7.3 Signal Conductor Currents

7

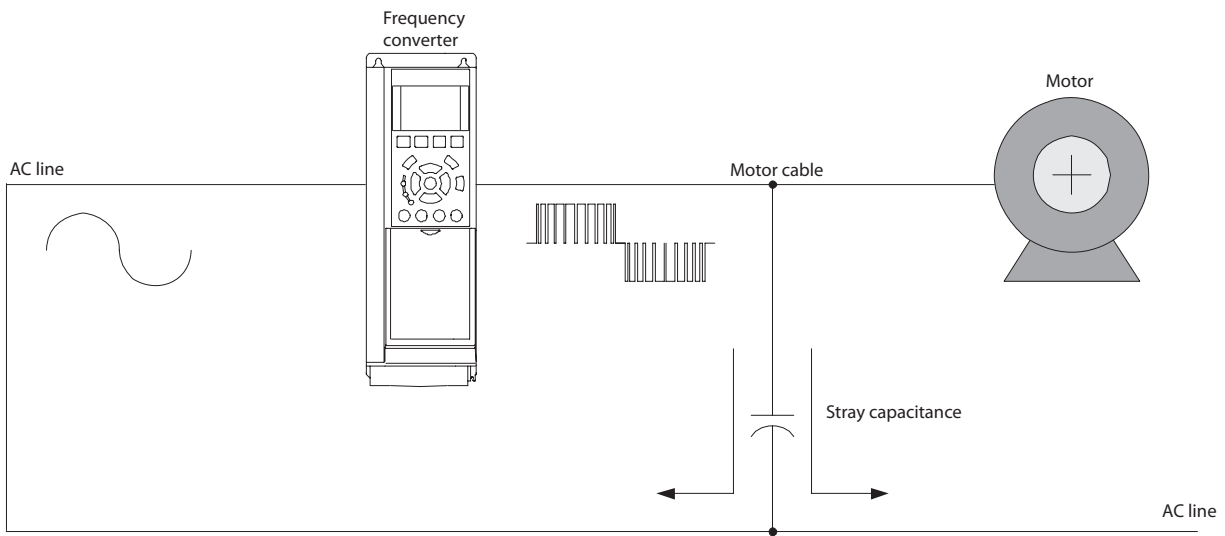

130BX140.12

Illustration 7.4 Alternate Signal Conductor Currents

7

7.3.5 Preventive Measures

EMI-related problems are more effectively alleviated during the design and installation phases rather than during service.

Grounding

The drive and motor must be solidly grounded to the equipment enclosure. A good high-frequency connection is necessary to allow the high-frequency currents to return back to the drive rather than to travel through the power network. The ground connection is ineffective if it has high impedance to high-frequency currents. Therefore it must be as short and direct as practical. Flat-braided cable has lower high-frequency impedance than round cable. Simply mounting the drive or motor onto a painted surface does not create an effective ground connection. In addition, running a separate ground conductor directly between the drive and the running motor is recommended.

Cable routing

Avoid routing the following in parallel:

- Motor wiring
- Mains wiring
- Signal wiring

If parallel routing is unavoidable, try to maintain a separation of 200 mm (6–8 in) between the cables, or separate them with a grounded conductive partition. Avoid routing cables through free air.

Signal cable selection

Single conductor 600 V rated wires provide the least protection from EMI. Twisted-pair cables and shielded twisted-pair cables are available that are designed to minimize the effects of EMI. While unshielded twisted-pair cables are often adequate, shielded twisted-pair cables provide another degree of protection. Terminate the signal cable shield in a manner that is appropriate for the connected equipment. Avoid terminating the shield through a pigtail connection as this method increases the high-frequency impedance and reduces the effectiveness of the shield. Refer to *chapter 4.9 Shielded Cable Grounding*.

A simple alternative is to twist the existing single conductors to provide a balanced capacitive and inductive coupling. This method cancels differential mode interference. While not as effective as true twisted-pair cable, it can be implemented in the field using the available materials.

Motor cable selection

The management of the motor conductors has the greatest influence on the EMI characteristics of the system. These conductors must receive the highest attention whenever EMI is a problem. Single conductor wires provide the least protection from EMI emissions. Often, if these conductors are routed separately from the signal and mains wiring, then no further consideration is needed. If the conductors are routed close to other susceptible conductors, or if the system is suspected to cause EMI problems, consider alternate motor wiring methods.

Installing shielded power cable is the most effective methods to alleviate EMI problems. The shield forces the noise current to flow directly back to the drive. This prevents it from flowing back into the power network or other undesirable high-frequency paths. Unlike most signal wiring, the shielding on the motor cable must be terminated at both ends.

If a shielded motor cable is not available, then 3-phase conductors plus ground in a conduit provides some protection. This technique is not as effective as shielded cable due to the unavoidable contact of the conduit with various points within the equipment.

Serial communications cable selection

There are various serial communication interfaces and protocols in the market. Each interface/protocol recommends 1 or more specific types of cables. Refer to the manufacturer documentation when selecting these cables. Similar recommendations apply to serial communication cables as to other signal cables. Using twisted-pair cables and routing them away from power conductors is encouraged. While shielded cable provides extra EMI protection, the shield capacitance can reduce the maximum allowable cable length at high data rates.

7

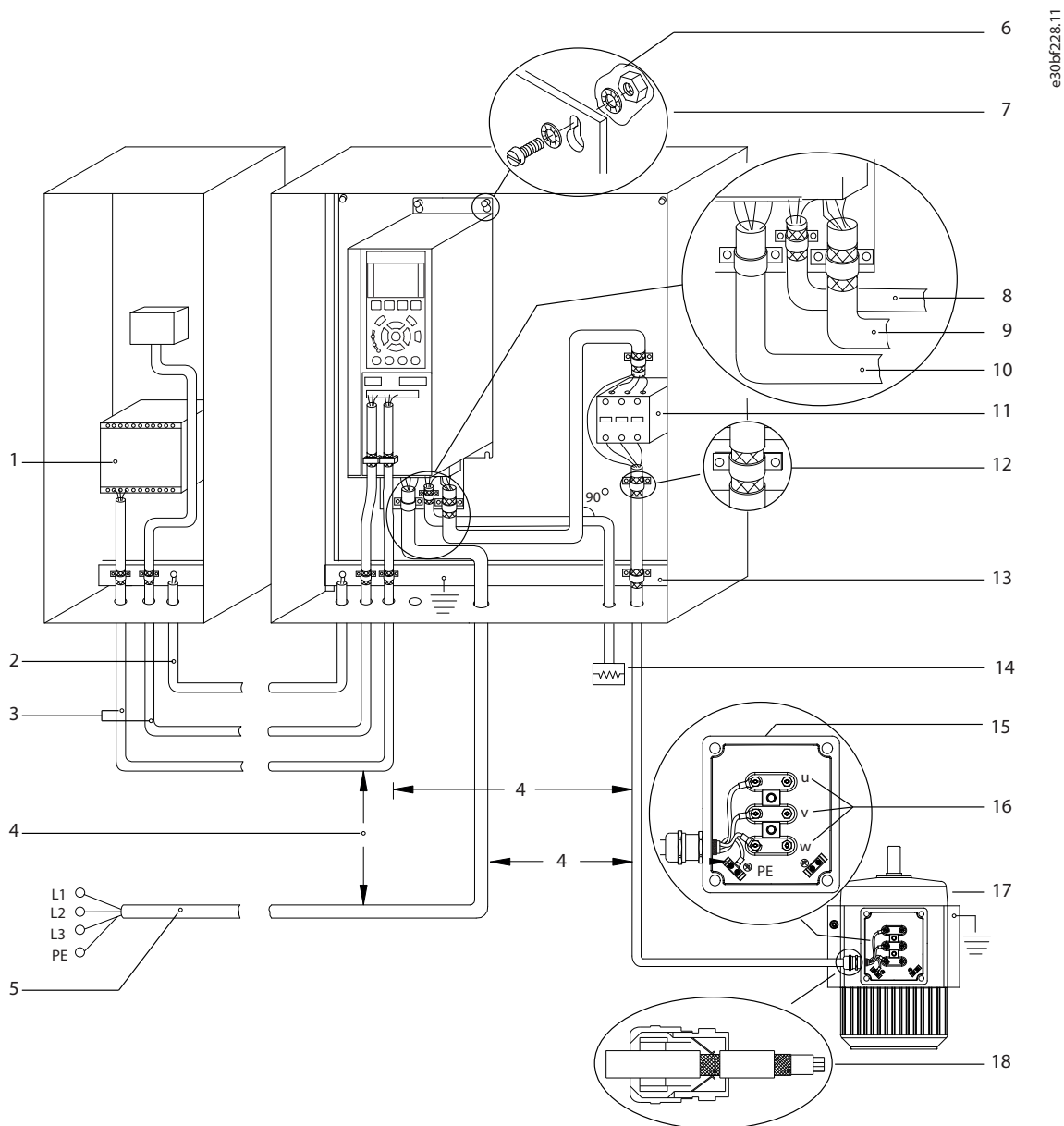

e30bf228.11

1	PLC	10	Mains cable (unshielded)
2	Minimum 16 mm ² (6 AWG) equalizing cable	11	Output contactor
3	Control cables	12	Cable insulation stripped
4	Minimum 200 mm (7.9 in) between control cables, motor cables, and mains cables.	13	Common ground busbar. Follow local and national requirements for cabinet grounding.
5	Mains supply	14	Brake resistor
6	Bare (unpainted) surface	15	Metal box
7	Star washers	16	Connection to motor
8	Brake cable (shielded)	17	Motor
9	Motor cable (shielded)	18	EMC cable gland

Illustration 7.5 Example of Proper EMC Installation

8 Test Procedures

8.1 Introduction

⚠ WARNING

DISCHARGE TIME

The drive contains DC-link capacitors, which can remain charged even when the drive is not powered. High voltage can be present even when the warning LED indicator lights are off. Failure to wait the specified time after power has been removed before performing service or repair work can result in death or serious injury.

- Stop the motor.
- Disconnect AC mains and remote DC-link power supplies, including battery back-ups, UPS, and DC-link connections to other drives.
- Disconnect or lock the motor.
- Disconnect any brake option.
- Disconnect any regen/load share option.
- Wait for the capacitors to discharge fully. The minimum waiting time is specified in the following discharge time table and is also visible on the drive label.
- Before performing any service or repair work, use an appropriate voltage measuring device to make sure that the capacitors are fully discharged. For parallel drive modules, measure DC-bus capacitor voltages before and after the individual DC fuses.

Enclosure Size	Minimum waiting time
D1h–D8h drives	20 minutes
J8–J9 drives	20 minutes
D9h–D10h enclosed drive systems	20 minutes
Da2/Da4/Db2/Db4 parallel drive systems	20 minutes
E1h–E4h drives	40 minutes
E5h–E6h enclosed drive systems	40 minutes

Table 8.1 Discharge Time

This section contains detailed procedures for testing drives. The results of these tests indicate the appropriate repair actions. The source of fault conditions is not always internal to the drive. For example, the drive monitors:

- I/O signals.
- Motor conditions.
- AC and DC power.
- Other functions.

Testing described in this chapter isolates many of these conditions.

Drive testing is divided into 3 types:

- Static tests.
- Dynamic tests.
- After-repair tests.

Static tests

Static tests are conducted without power applied to the drive. Most drive problems can be diagnosed with these tests. Static tests are performed with little or no disassembly. The purpose of static testing is to check for shorted power components. Perform these tests on any unit suspected of containing faulty power components before applying power.

Dynamic tests

Dynamic tests are performed with power applied to the drive. Dynamic testing traces signal circuitry to isolate faulty components.

After-repair tests

After-repair tests are performed following service work or parts replacement. These procedures retest the drive with the new component before power is applied.

8.2 Tools Required

Item	Description
ESD protection kit	Wrist strap and mat
Metric socket set	7–19 mm
Socket extensions	100–150 mm (4 in and 6 in)
Magnetic sockets	–
Ratchet wrench	–
Torque wrench	Torque range 0.5–19 Nm (6–170 in-lb)
Torx driver set	T10–T50
Needle nose pliers	–
Screwdrivers	Standard and Phillips

Table 8.2 Tools Required to Service Drives

Item	Description
Digital Volt-Ohm Meter (PWM-compatible)	<ul style="list-style-type: none"> Rated for true RMS. Rated for the mains AC voltage and DC-link voltage of the drive. (DC-link voltage = 1.414 x mains voltage). Supports the diode mode.
Analog voltmeter (with safety probe tip extenders)	–
Oscilloscope	–
Clamp-on ammeter	Rated for true RMS
Split bus power supply	p/n 130B3146
Signal test board	p/n 176F8437
Parallel drive module service kit ¹⁾	p/n 176F3745

Table 8.3 Instruments Recommended to Test Drives

1) Used for testing only VLT® Parallel Drive Modules.

8.2.1 Special Test Equipment

Special test tools have been developed to aid in testing VLT® FC Series drives. The tools are required to perform some of the procedures outlined in this chapter. See *chapter 9 Special Test Equipment* for more information.

- Split bus power supply (p/n 130B3146)
- Parallel drive module service kit (p/n 176F3745)
- Signal test board (p/n 176F8437)

8.2.2 Signal Test Board

The signal test board is used to test circuitry within the drive and provides easy access to test points. Its use is described in the procedures where called out. See *Table 9.2*, for detailed pin descriptions.

The connector for the signal test board is on the power card. To access the power card, remove the control card mounting plate from the drive. Refer to *chapter 10.2.2 Control Card and Control Card Mounting Plate* or *chapter 13.2.2 Control Card and Control Card Mounting Plate*. Then, plug the signal test board into power card connector MK104.

8.2.3 Metering Tools

For best troubleshooting results, perform the static test procedures described in this section in the order presented.

Perform all tests with a meter capable of testing diodes. Use a digital Volt-Ohm Meter (VOM) set on the diode scale or an analog ohmmeter set on Rx100 scale. Before making any checks, disconnect all input, motor, and brake resistor connections.

Diode drop

A diode drop reading varies depending on the model of ohmmeter. Whatever the ohmmeter shows as a typical forward bias diode is defined as a diode drop in these procedures. With a typical DVM, the voltage drop across most components is around 0.300 to 0.500. The opposite reading is referred to as infinity, and most show the value OL for overload.

8.3 Test Preparations

NOTICE

TEST ORDER

For best results, perform the static test procedures in this section in the order they appear.

Observe the following safety precautions before performing the static tests:

- Prepare the work area according to the ESD regulations.
- Ground the ESD mat and wrist strap.
- Ensure that the ground connection between body, the ESD mat, and the drive is always present while performing service.
- Handle disassembled electronic parts with care.
- Perform the static tests before powering up the faulty unit.
- Perform the static tests after completing the repair and assembly of the drive.
- Connect the drive to the mains only after completion of static tests.
- Complete all necessary precautions for system start-up, before applying power to the drive.

WARNING

DISCHARGE TIME

The drive contains DC-link capacitors, which can remain charged even when the drive is not powered. High voltage can be present even when the warning LED indicator lights are off. Failure to wait the specified time after power has been removed before performing service or repair work can result in death or serious injury.

- Stop the motor.
- Disconnect AC mains and remote DC-link power supplies, including battery back-ups, UPS, and DC-link connections to other drives.
- Disconnect or lock the motor.
- Disconnect any brake option.
- Disconnect any regen/load share option.
- Wait for the capacitors to discharge fully. The minimum waiting time is specified in the following discharge time table and is also visible on the drive label.
- Before performing any service or repair work, use an appropriate voltage measuring device to make sure that the capacitors are fully discharged. For parallel drive modules, measure DC-bus capacitor voltages before and after the individual DC fuses.

Enclosure Size	Minimum waiting time
D1h–D8h drives	20 minutes
J8–J9 drives	20 minutes
D9h–D10h enclosed drive systems	20 minutes
Da2/Da4/Db2/Db4 parallel drive systems	20 minutes
E1h–E4h drives	40 minutes
E5h–E6h enclosed drive systems	40 minutes

Table 8.4 Discharge Time

8.3.1 Preparations for Parallel Drive Systems

When testing parallel drive systems, observe the following practices.

- To access the DC link, use the regen terminals at the top of the module. All parallel drive modules have regen terminals. See *Illustration 8.2*.
- When testing the entire system, it is not necessary to remove the interlink connections between the DC links, input terminals, and output terminals.
- When testing an individual module within a parallel system, isolate the module by removing the interlink connections and the control cable connections of the module.
- For information on testing an individual module after repair, and before placing it back into the parallel system, refer to *chapter 8.6.2 After-repair Tests for Parallel Drive Systems*.

8.3.2 Access to Testing Connection Points

Many of the following test procedures require access to the DC bus. For the DC bus location in D1h–D8h units, see *Illustration 8.1*. For parallel drive systems, see *Illustration 8.2*. For E1h–E4h drives, see *Illustration 8.3*.

NOTICE

DC BUS LOCATION

To reach the DC bus location in D1h–D8h units, use a voltmeter with safety probe tip extenders.

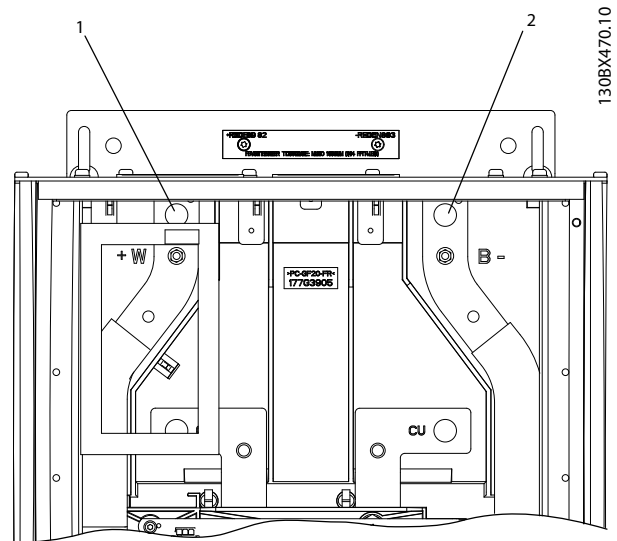

1	DC(+) bus
2	DC(-) bus
Fasteners are M5 studs.	

Illustration 8.1 DC Bus Location in D1h–D8h Drives

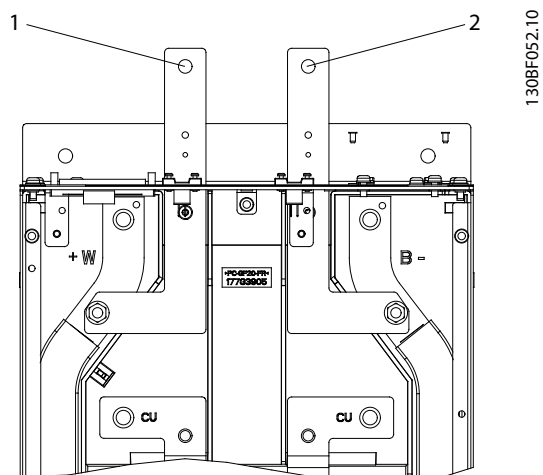

1	DC(+) bus
2	DC(-) bus
Fasteners are M5 studs.	

Illustration 8.2 DC Bus Location in Parallel Drive Systems

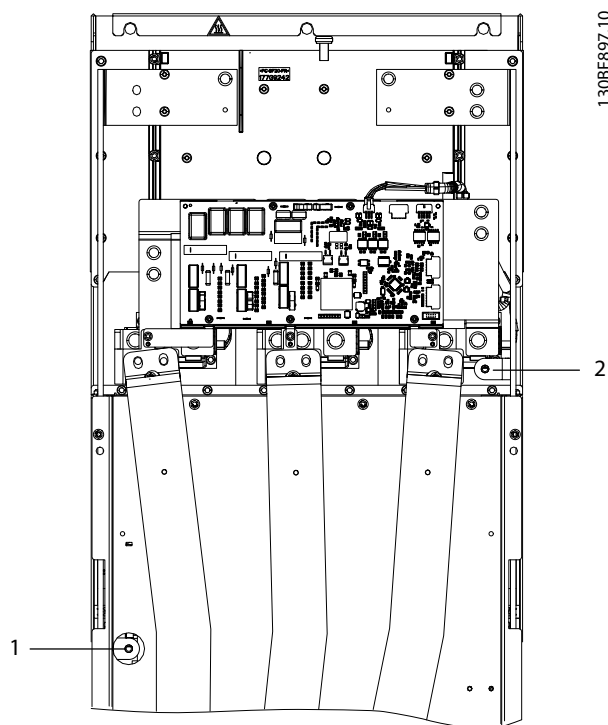

1	DC(+) bus
2	DC(-) bus

Illustration 8.3 DC Bus Location in E1h-E4h Drives

8.3.3 Card Connectors

This section includes illustrations of printed circuit cards and descriptions of their connectors used during testing and servicing. Some connectors are optional and not found on all configurations. The printed circuit cards shown include:

- Power card
- Fan power card
- Multi-drive control interface card (MDCIC)
- Gate drive card

Power cards and MDCIC

In D1h-D8h and E1h-E4h drives, the current scaling card is mounted on the power card. In parallel drive systems, all current scaling cards are connected to the multi-drive control interface card (MDCIC) on the control shelf.

8.3.4 Power Card in D-sized Drives

8

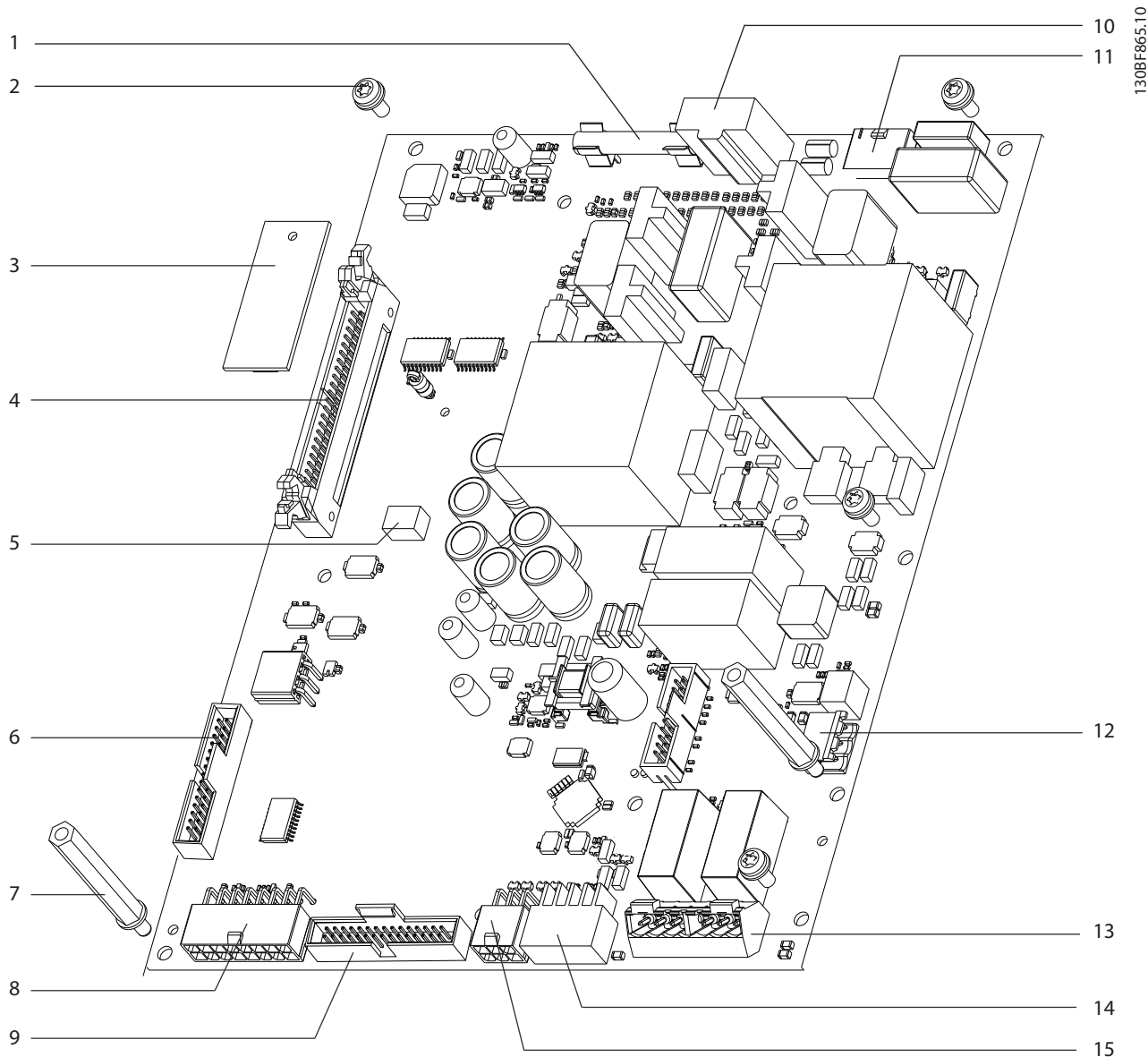

130BF865.10

1	FK901: SMPS fuse	9	MK103: Connector to gate drive card
2	Screw (T20)	10	MK901: DC input terminals (used with split bus power supply)
3	Current scaling card (not in parallel drive modules)	11	MK902: DC voltage from DC bus to power card SMPS
4	MK102: Control card to power card connection	12	MK106: Brake temperature switch input
5	MK100: Scaling card connector (not in parallel drive modules)	13	MK500: Customer terminals for relays 1 and 2
6	MK104: Signal test board connector	14	MK501: Heat sink and door/top fan control
7	Standoff (8 mm)	15	MK502: EMC relay control
8	MK101: Current sensor feedback	–	–

Illustration 8.4 Power Card in D-sized Drives

8.3.5 Power Card in E-sized Drives

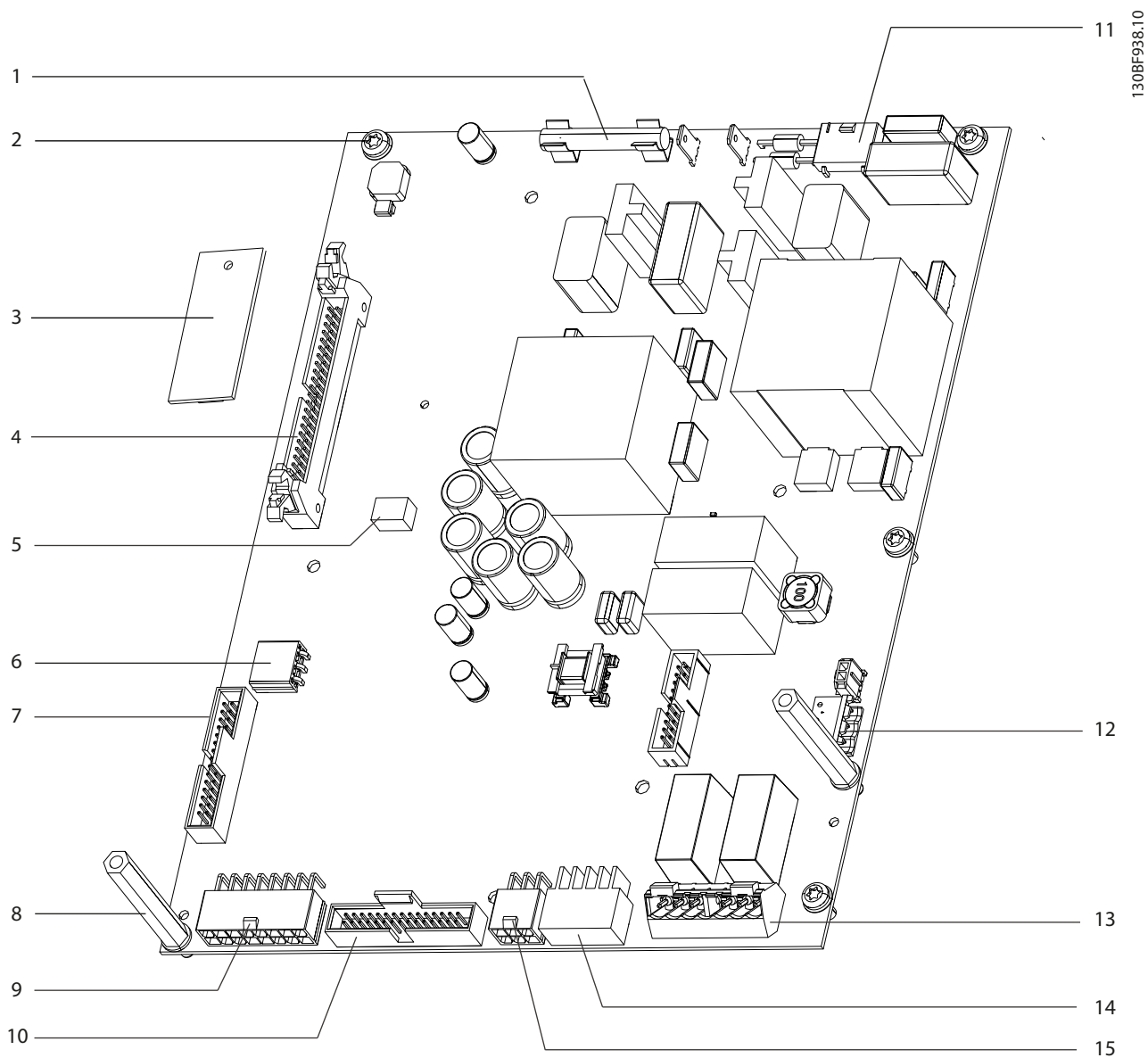

1	FK901: SMPS fuse	9	MK101: Current sensor feedback
2	Screw (T20)	10	MK103: Connector to gate drive card
3	Current scaling card	11	MK902: Fan power card signals (MK803)
4	MK102: Ribbon cable to control card	12	MK106: Brake temperature switch input
5	MK100: Current scaling card connector	13	MK500: Customer terminals for relays 1 and 2
6	MK105: CANBUS connection to fan power card	14	MK501: Mixing fan control
7	MK104: Signal test board connector	15	MK502: EMC relay control
8	Standoff (8 mm)	-	-

Illustration 8.5 Power Card in E-sized Drives

8.3.6 MDCIC in Parallel Drive Systems

130BF05.1.10

8

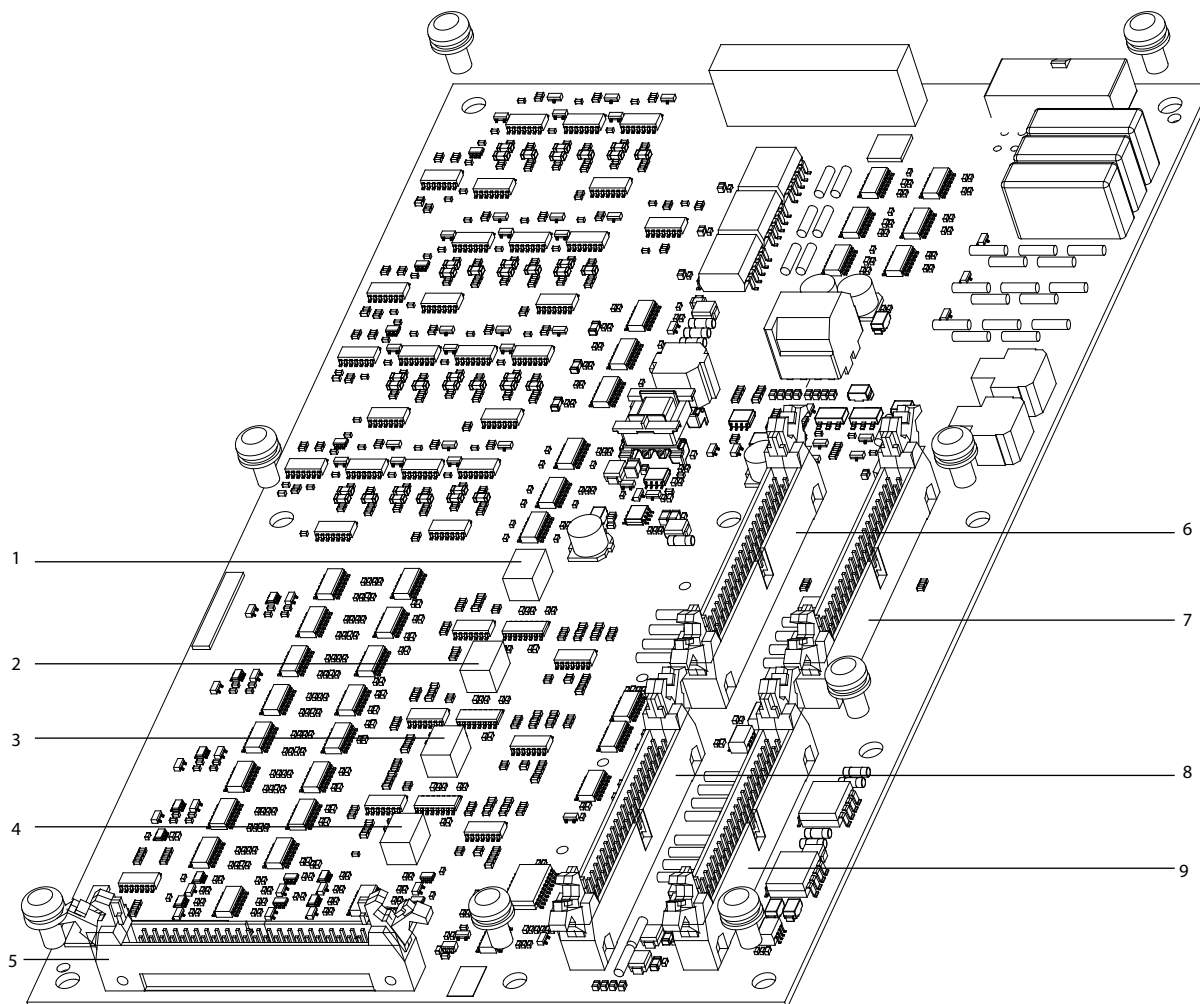

1	MK110: Connector for current scaling card for module 4	6	MK113: Connector to module 3
2	MK109: Connector for current scaling card for module 3	7	MK114: Connector to module 4
3	MK108: Connector for current scaling card for module 2	8	MK111: Connector to module 1
4	MK107: Connector for current scaling card for module 1	9	MK112: Connector to module 2
5	MK100: MDCIC-to-control card connection	-	-

Illustration 8.6 MDCIC in Parallel Drive Systems

8.3.7 Fan Power Card in E-sized Drives

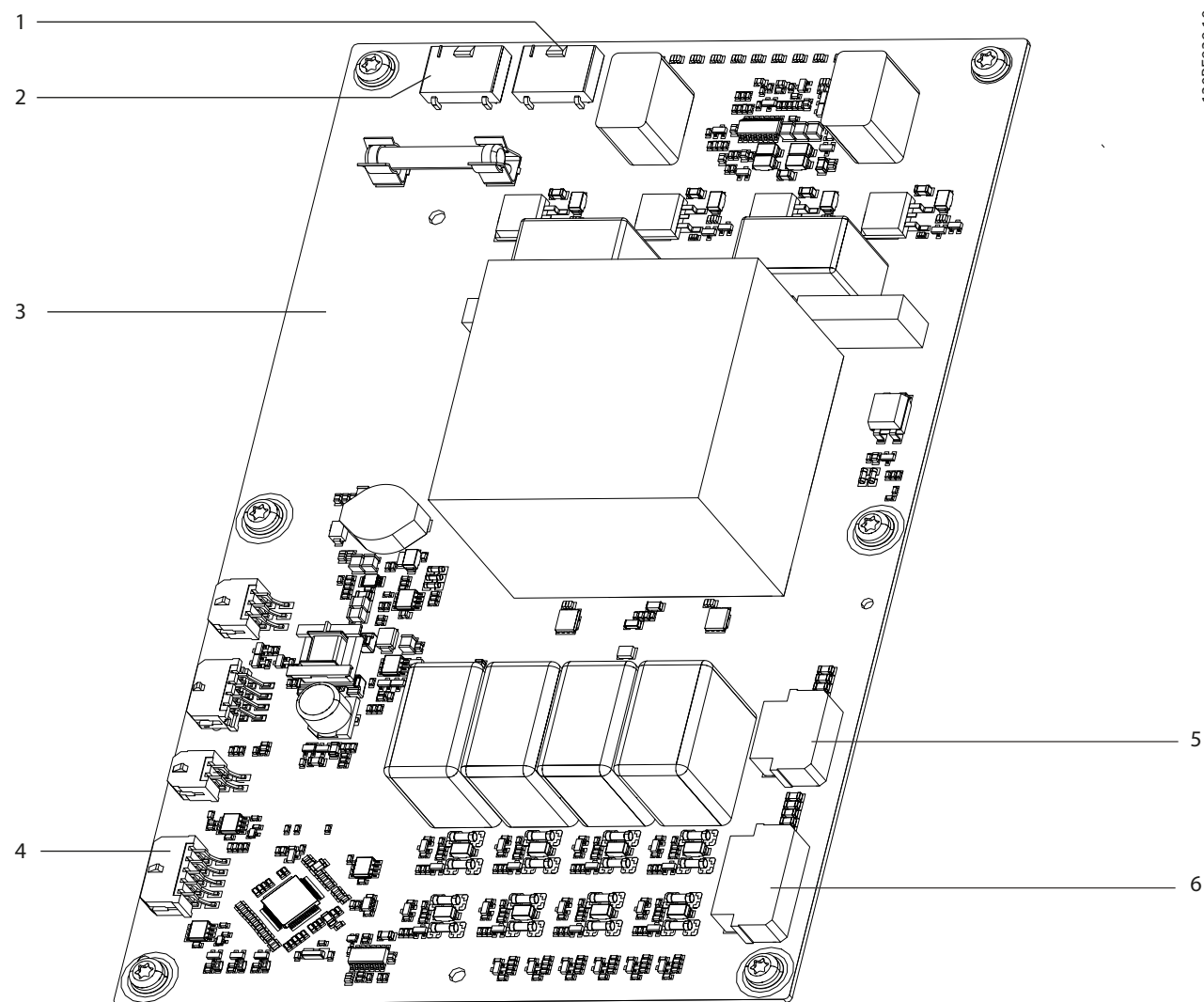

130BF939.10

1	MK802: DC power	4	MK1200: Inrush card (MK110) and power card (MK105)
2	MK803: Power card signals (MK902)	5	MK602: Door/top fan control
3	Fan power card (PCA16)	6	MK600: Heat sink fan control

Illustration 8.7 Fan Power Card in E-sized Drives

8.3.8 Gate Drive Card in D-sized Drives

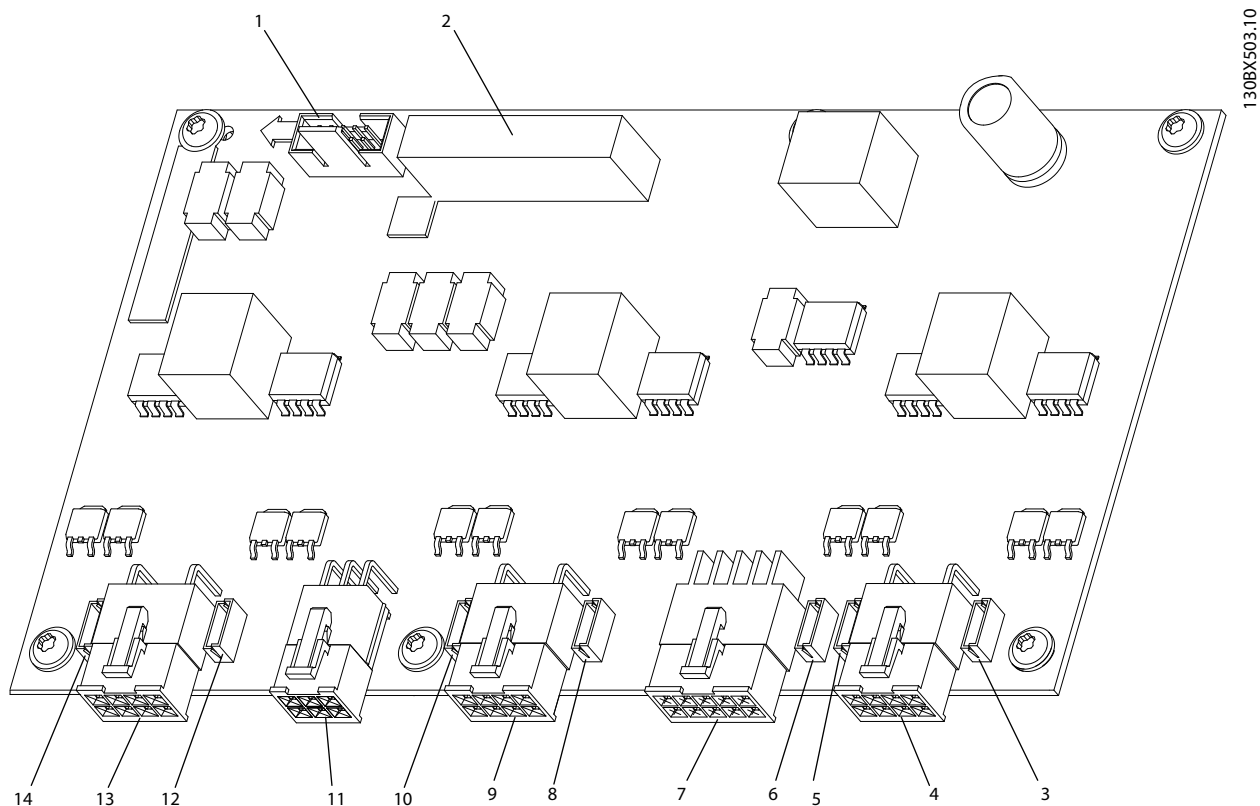

1	MK102: Connection to inrush board	8	MK600: V phase upper IGBT test point
2	MK101: Gate drive/inrush signals to power card	9	MK601: V phase IGBT gate signal
3	MK700: W phase upper IGBT test point	10	MIK602: V phase lower IGBT test point
4	MK701: W phase IGBT signal	11	MK100: IGBT temperature feedback
5	MK702: W phase lower IGBT test point	12	MK500: U phase upper IGBT test point
6	MK200: Brake IGBT test point (optional)	13	MK501: U phase IGBT gate signal
7	MK201: Brake IGBT gate signal (optional)	14	MK502: U phase lower IGBT test point

Illustration 8.8 Gate Drive Card in D-sized Drives

8.3.9 Gate Drive Card in E-sized Drives

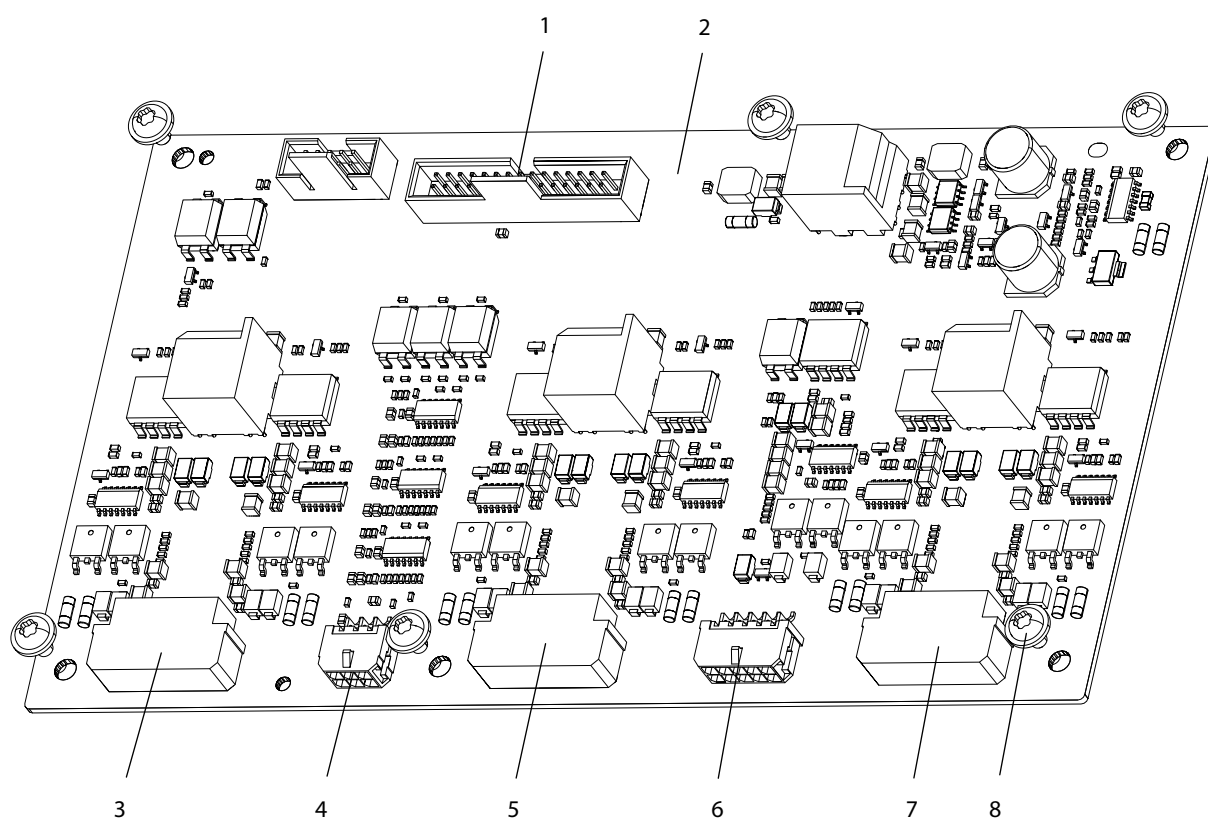

130BF936.10

1	MK101: Gate drive signals to power card	5	MK601: V phase IGBT gate signal
2	Gate drive card	6	MK201: Brake IGBT gate signal (optional)
3	MK501: U phase IGBT gate signal	7	MK701: W phase IGBT signal
4	MK100: IGBT temperature feedback	8	Screw (T20)

Illustration 8.9 Gate Drive Card in E-sized Drives

8.4 Static Test Procedures

NOTICE

TEST ORDER

For best troubleshooting results, perform the static test procedures described in this section in the order presented.

To find the appropriate card connectors for performing the tests in this section, see *chapter 8.3.3 Card Connectors*. Some connectors are optional and not found on all configurations.

8.4.1 Rectifier Circuits Test

Pay close attention to the polarity of the meter leads to identify a faulty component if an incorrect reading appears.

NOTICE

OPTIONAL EQUIPMENT TESTS

For units with a circuit breaker, contactor, disconnect, or mains fuse option, make test connections L1 (R), L2 (S), and L3 (T) to the output side of the devices.

NOTICE

PARALLEL SYSTEM TESTS

Before performing these tests in a parallel drive system, isolate the individual module to be tested. To isolate the module, remove the:

- DC link connection
- Motor busbar/cable links
- Input busbar/cable links

Main rectifier circuit test part I

1. Connect the positive (+) meter lead to the positive DC(+) bus.
2. Connect the negative (-) meter lead to terminals L1, L2, and L3 in sequence.

If the unit is a parallel drive module, make test connections between the DC bus and the module input.

The correct reading is infinity. The meter starts at a low value and slowly climbs toward infinity due to the meter charging capacitance within the drive.

Incorrect reading

With this test connection, the SCRs in the SCR/diode modules are reverse biased so they are blocking current flow. If a short circuit exists, it indicates that the SCRs are shorted. Replace the shorted SCR/diode module.

Main rectifier circuit test part II

1. Reverse meter leads by connecting the negative (-) meter lead to the positive DC(+) bus.
2. Connect the positive (+) meter lead to L1, L2, and L3 in sequence.

The correct reading is infinity.

Incorrect reading

With this test connection, the SCRs in the SCR/diode modules are forward biased by the meter. However, current does not flow through the SCRs without providing a signal to the gates.

A short circuit reading indicates that 1 or more of the SCRs are shorted in the SCR/diode module. Replace the shorted SCR/diode module.

Main rectifier circuit test part III

1. Connect the positive (+) meter lead to the negative DC(-) bus.
2. Connect the negative (-) meter lead to terminals L1, L2, and L3 in sequence.

A diode drop indicates a correct reading.

Incorrect reading

With this test connection, the diodes in the SCR/diode modules are forward biased. The meter reads the diode drops. If a short circuit exists, it is possible that the SCR/diode modules are shorted. Replace the shorted SCR/diode module.

If an open reading occurs, replace the open SCR/diode module.

Main rectifier circuit test part IV

1. Reverse meter leads by connecting the negative (-) meter lead to the negative DC(-) bus.
2. Connect the positive (+) meter lead to L1, L2, and L3 in sequence.

Infinity is the correct reading. The meter starts at a low value and slowly climbs toward infinity due to the meter charging capacitance within the drive.

Incorrect reading

With this test connection, the diodes in the SCR/diode modules are reverse biased. If a short circuit exists, the diodes in the SCR/diode modules are shorted. Replace the shorted SCR/diode module.

8.4.2 Inverter Section Tests

NOTICE

PARALLEL MODULE ISOLATION

Before performing these tests in a parallel drive system, isolate the individual module to be tested. To isolate the module, remove the:

- DC link connection.
- Motor busbar/cable links.
- Input busbar/cable links.

NOTICE

MOTOR CABLE REMOVAL

Disconnect motor cables when testing the inverter section. When leads are connected, a short circuit in a single phase reads in all phases, making isolation difficult.

The inverter section consists primarily of the IGBTs used for switching the DC bus voltage to create the output to the motor. The IGBTs are grouped into modules. D-sized drives use 1 module per phase. E-sized drives use 2 modules per phase.

Inverter test part I

1. Set the meter to diode scale.
2. Connect the positive (+) meter lead to the (+) positive DC bus.
3. Connect the negative (-) meter lead to terminals U, V, and W in sequence.

Infinity is the correct reading. The meter starts at a low value and slowly moves toward infinity due to the meter charging capacitance within the drive.

Inverter test part II

1. Reverse the meter leads by connecting the negative (-) meter lead to the positive DC(+) bus.
2. Connect the positive (+) meter lead to U, V, and W in sequence.

A diode drop indicates a correct reading.

Inverter test part III

1. Connect the positive (+) meter lead to the negative DC(-) bus.
2. Connect the negative (-) meter lead to terminals U, V, and W in sequence.

A diode drop indicates a correct reading.

Inverter test part IV

1. Reverse the meter leads by connecting the negative (-) meter lead to the negative DC(-) bus.
2. Connect the positive (+) meter lead to U, V, and W in sequence.

Infinity is the correct reading. The meter starts at a low value and slowly moves toward infinity due to the meter charging capacitance within the drive.

Incorrect reading

An incorrect reading in any inverter test indicates a failed IGBT module. Replace all the IGBT modules. Following an IGBT failure, verify that the gate drive signals are present and the wave form is correct. See *chapter 8.5.11 IGBT Gate Drive Signals Test*.

8.4.3 Brake IGBT Test

This test can only be carried out on units equipped with a dynamic brake option. If a brake resistor is connected to terminals R-(81) and R+(82), disconnect it before proceeding. Use an ohmmeter set on diode check or Rx100 scale.

Brake IGBT test part I

1. Connect the positive (+) meter lead to the brake resistor terminal 82 (R+).
2. Connect the negative (-) meter lead to the brake resistor terminal 81 (R-).

Infinity is a correct reading. The meter starts at a value and climbs toward infinity as capacitance is charged within the drive.

Brake IGBT test part II

1. Connect the positive (+) meter lead to the brake resistor terminal 81 (R-).
2. Connect the negative (-) meter lead to the brake resistor terminal 82 (R+).

A diode drop indicates a correct reading.

Brake IGBT test part III

1. Connect the positive (+) meter lead to the brake resistor terminal 81 (R-).
2. Connect the negative (-) meter lead to the negative DC(-) bus.

Infinity is a correct reading. The meter starts at a value and climbs toward infinity as capacitance is charged within the drive.

Brake IGBT test part IV

1. Connect the negative (-) meter lead to the brake resistor 81 (R-).
2. Connect the positive (+) meter lead to the negative DC(-) bus.

A diode drop indicates a correct reading.

Incorrect reading

An incorrect reading on any of these tests indicates that the brake IGBT is defective. Replace the brake IGBT module.

8.4.4 Intermediate Section Tests**NOTICE****PARALLEL MODULE ISOLATION**

Before performing these tests in a parallel drive system, isolate the individual module to be tested. To isolate the module, remove the:

- DC link connection.
- Motor busbar/cable links.
- Input busbar/cable links.

The intermediate section of the drive is composed of the:

- DC bus capacitors.
- DC coils.
- Balance circuit for the capacitors.

Intermediate section test

1. Test for short circuits with the ohmmeter set to Rx100 scale. If using a digital meter, select diode.
2. Connect the positive (+) meter lead to the DC(+) and the negative (-) meter lead to the negative DC(-).
3. The meter starts with low ohms and then moves toward infinity as the meter charges the capacitors.
4. Reverse the meter leads so that the (-) meter lead is connected to the positive DC(+) and the positive (+) meter lead is connected to the negative DC(-).
5. The meter pegs at 0 while the meter discharges the capacitors. The meter then begins moving slowly toward 2 diode drops as the meter charges the capacitors in the reverse direction. Although the test does not ensure that the capacitors are fully functional, it ensures that no short circuits exist in the DC link.

Incorrect reading

A short in the rectifier or inverter section could cause a short circuit reading. Ensure that the tests for these circuits have already been performed successfully. A failure in 1 of these sections could be read in the intermediate section since they are all routed via the DC bus.

If a short circuit is present, and the unit is equipped with a brake, perform the brake IGBT test next.

The only other likely cause for failure would be a defective capacitor.

There is not an effective test of the capacitor bank when it is fully assembled. It is unlikely that a physically damaged capacitor would indicate a failure within the capacitor bank. If a failure is suspected, all the capacitors must be replaced. Replace the capacitors in accordance with *chapter 10.2.20 Standard DC Capacitors*, *chapter 11.2.20 Standard DC Capacitors*, or *chapter 13.2.20 Twistlock DC Capacitors*.

Further static tests could require some disassembly. See *chapter 10 D1h/D3h/D5h/D6h/J8 Drive Disassembly and Assembly* to *chapter 13 E1h–E4h Drive Disassembly and Assembly*.

8.4.5 IGBT Temperature Sensor Test

The temperature sensor is an NTC (negative temperature coefficient) device. As a result, high resistance means low temperature. As the temperature increases, resistance decreases. Each IGBT module has a temperature sensor mounted internally. The sensor is wired from each IGBT module to the gate drive card connector MK100.

On the gate drive card, the resistance signal is converted to a frequency signal. The frequency signal is sent to the power card for processing. The temperature data is used to regulate fan speed and to monitor for over and under temperature conditions. In D-sized drives, there are 3 sensors, 1 in each IGBT module. In E-sized drives, there are 6 IGBT modules; the left IGBT of each phase is monitored.

In E-sized drives, individual IGBT module temperatures can be viewed in *parameter 43-00 Component Temp*:

- *Parameter 43-10 Heat Sink Phase U Temp ID* shows U-phase temperature.
- *Parameter 43-11 Heat Sink Phase V Temp ID* shows V-phase temperature.
- *Parameter 43-12 Heat Sink Phase W Temp ID* shows W-phase temperature.

IGBT section test

1. Use ohmmeter set to read ohms.
2. Unplug connector MK100 on the gate drive card (see *Illustration 8.8*) and measure the resistance across each black and white pair.

The relationship between temperature and resistance is nonlinear. At 25 °C (77 °F), the resistance is approximately 5k Ω . At 0 °C (32 °F), the resistance is approximately 13.7 k Ω . At 60 °C (140 °F), the resistance is approximately 1.5 k Ω . The higher the temperature, the lower the resistance.

8.4.6 Gate Resistor Test

Mounted to each IGBT module is an IGBT gate resistor card containing gate resistors for the IGBT transistors. Occasionally, a defective IGBT can produce correct readings in the previous tests. Typically, an IGBT failure results in the failure of the gate resistors, so the gate resistor test can identify an IGBT failure.

NOTICE

DRIVE TYPE

This test is applicable to only D-sized drives. E1h–E4h drives do not have test connectors on the gate drive card.

To access the gate drive card, see *chapter 10.2.17 Gate Drive Card*, *chapter 11.2.14 Gate Drive Card*, or *chapter 13.2.14 Gate Drive Card*.

In D-sized drives, a 3-pin test connector is found on the gate drive card near each gate signal lead. These leads are labeled:

- MK500
- MK502
- MK600
- MK602
- MK700
- MK702
- MK200 (if brake option is present).

See *Illustration 8.8*.

For clarification, refer to the 3 pins as 1, 2, and 3, reading bottom to top. Pins 1 and 2 of each connector are in parallel with the gate drive signal sent to the IGBTs. Pin 1 is the signal and pin 2 is common.

Gate resistor test

1. With an ohmmeter, measure pins 1 and 2 of each test connector.
2. Confirm that the reading is the same for each test connector.

Incorrect reading

An incorrect reading can indicate that:

- The gate signal wires are not connected from the gate drive card to the gate resistor board.
- The gate resistors are defective.

Connect the gate signal wires if necessary. If any of the resistors are defective, replace the entire IGBT module assembly. See *chapter 10.2.19 IGBTs*, *chapter 11.2.19 IGBTs*, or *chapter 13.2.22 IGBTs*.

8.4.7 Mains Fuse/DC Fuse Test

In D1h–D8h units, optional mains fuses are located in either of 2 places. Usually, they are found in the main enclosure. When an optional contactor and disconnect are both present, the mains fuses are located in the extended options cabinet between these 2 components. In E1h–E4h units, the optional AC fuses are located in the main enclosure mounted in front of the input plate.

In parallel drive modules, the mains fuses are located in the main module enclosure. In parallel drive systems, the DC fuses are found at the top of each module.

Mains fuse/DC fuse test

Perform the following fuse test. If the unit is a parallel drive module, perform the test on the DC fuse.

1. Use an ohmmeter set to measure the ohms.
2. Measure the resistance across each fuse.

A short circuit indicates good continuity.

Incorrect reading

An open circuit means that the fuse requires replacement. Perform the additional static checks before replacing the fuse.

8.4.8 Disconnect Test

The mains disconnect switch is optional. In D-sized drives, the disconnect is located in the extended options cabinet. In E-sized drives, the disconnect option is integrated into the drive enclosure.

For the mains disconnect test:

1. Use an ohmmeter set to read ohms.
2. Open the disconnect switch.
3. Measure the resistance across each of the 3 phases.

An open circuit (infinite resistance) is a correct reading. A short circuit (0 Ω) indicates a problem with the switch.

1. Close the disconnect switch.
2. Measure the resistance across each of the 3 phases.

A short circuit (0 Ω) is a correct reading. An open circuit (infinite resistance) or high-resistance reading indicates a problem with the switch. Replace the disconnect switch.

8.4.9 Circuit Breaker Test

NOTICE

DRIVE TYPE

This test is applicable to only D1h–D8h drives.

The circuit breaker is optional. If present in a D-sized unit, the circuit breaker is located in the option cabinet.

1. Use an ohmmeter set to read ohms.
2. Open the circuit breaker.
3. Measure the resistance across each of the 3 phases.

An open circuit (infinite resistance) is a correct reading. A short circuit (0 Ω) indicates a problem with the circuit breaker.

1. Close the circuit breaker.
2. Measure the resistance across each of the 3 phases.

A short circuit (0 Ω) is a correct reading. An open circuit (infinite resistance), or high-resistance reading indicates a problem with the circuit breaker.

If there is a problem with any of the phases, replace the circuit breaker.

8.4.10 Contactor Test

NOTICE

OPTION AVAILABILITY

The contactor option is available only in D-sized drives.

The contactor is optional. If present, it is located in the option cabinet. The contactor uses a customer-supplied 230 V AC control signal wired to the contactor coil. When power is applied to the contactor coil, the contactor is closed. When there is no power, the contact is open.

NOTICE

POWER REQUIREMENTS

Complete testing of the contactor requires an external 230 V AC supply.

Contactor test part I

1. Remove power to the contactor coil.
2. To measure across each of the 3 phases, use an ohmmeter.

An open circuit (infinite resistance) is a correct reading. A short circuit (0 Ω) indicates a problem with the contactor.

Contactor test part II

1. Manually engage the contactor.
2. With the contactor engaged, measure the resistance across each of the 3 phases.

A short circuit (0 Ω) is the proper reading. An open circuit (infinite resistance) or high-resistance reading indicates a problem with the contactor.

Contactor coil test

NOTICE

POWER REQUIREMENTS

Testing of the contactor coil requires 230 V AC power.

1. Apply power to the coil, energizing the contactor.
2. Use a voltmeter set to measure AC voltage between A1 and A2 on TB6.
3. Measure the resistance across each of the 3 phases.

When power is applied, the contactor energizes and is engaged. A short circuit (0 Ω) is a correct reading. An open circuit (infinite resistance) or high-resistance reading indicates a problem with the contactor.

If there is a problem with any of the phases, replace the contactor.

8.5 Dynamic Test Procedures

WARNING

RISK OF INJURY/SHOCK HAZARD

Contact with powered components can result in death or serious injury. Before starting the drive or performing any dynamic test procedures, take all the necessary safety precautions for system start-up. Refer to *chapter 2 Safety*.

- Do not disconnect the input cabling while power is applied to the drive.
- Do not touch energized parts of the drive when connected to mains.

NOTICE

TEST ORDER

Test procedures in this section are numbered for reference only. Perform dynamic tests in any order and only as necessary. Always perform static tests (*chapter 8.4 Static Test Procedures*) before applying power to the unit.

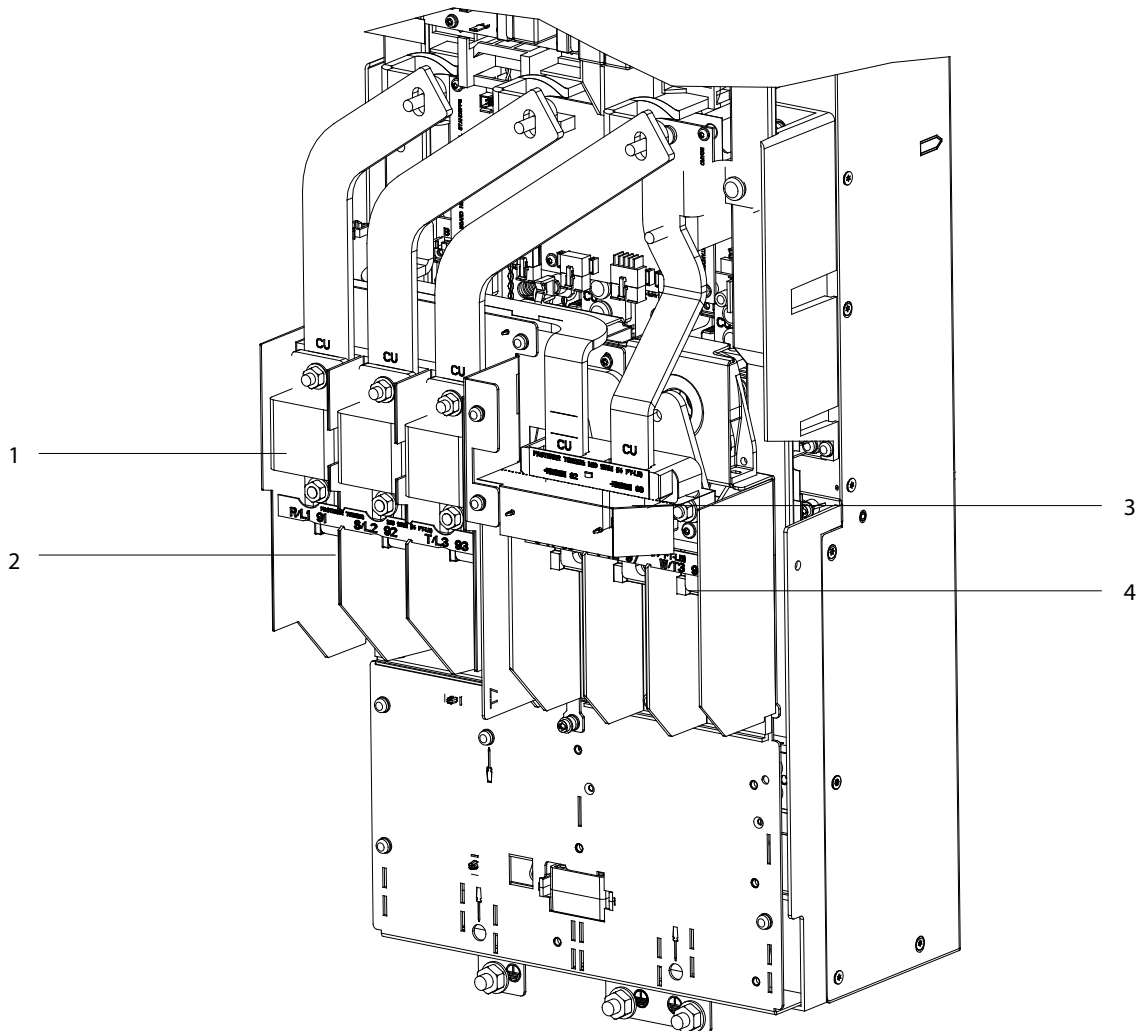

130BF089.10

1	AC fuse	3	Brake terminals (optional)
2	Input terminals	4	Output terminals

Illustration 8.10 Power Terminals in D-sized Drive

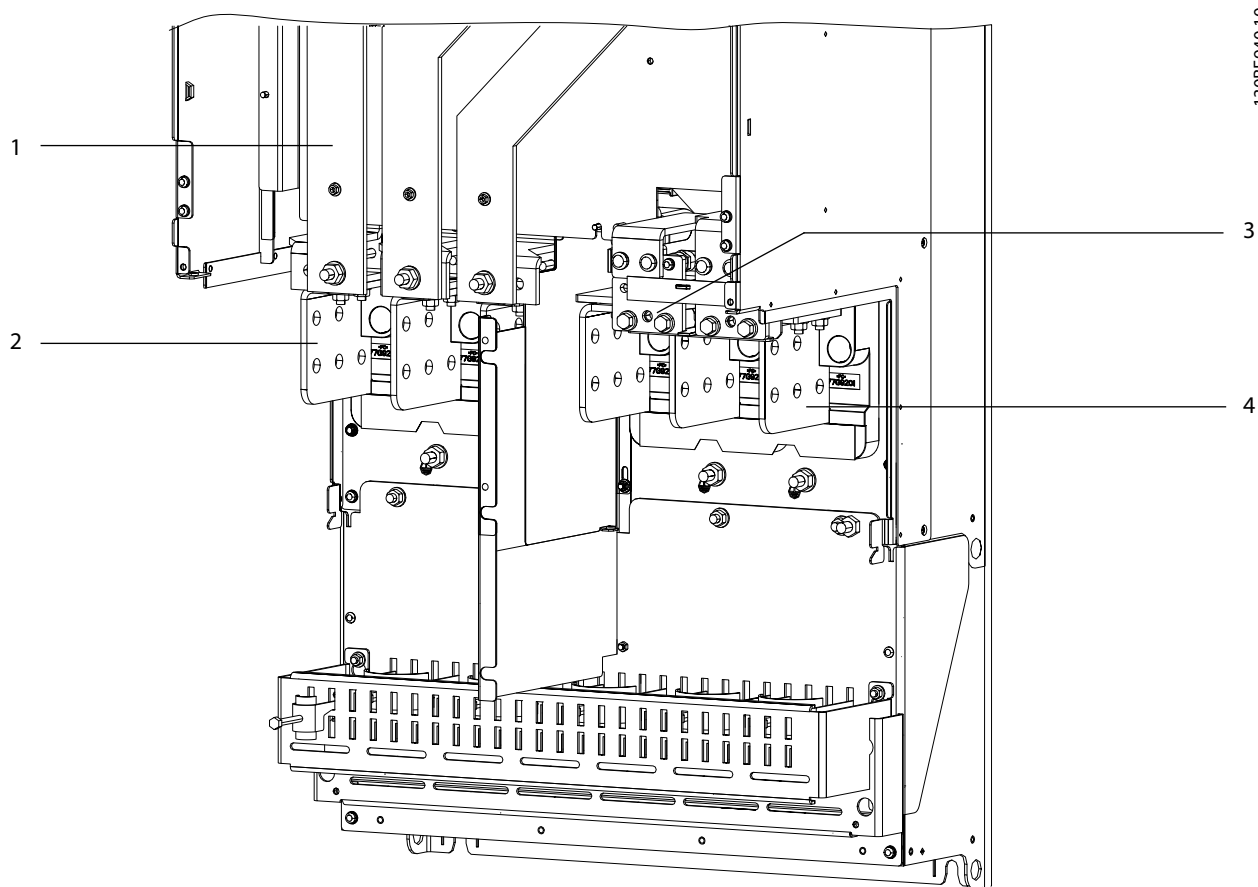

8

1	AC input busbar	3	Brake/regen terminals (optional)
2	Input terminals	4	Output terminals

Illustration 8.11 Power Terminals in E-sized Drives

Whenever possible, perform these procedures with a split bus power supply. For more information, see *chapter 9.1.1 Overview*.

8.5.1 No Display Test

A drive with no display can be the result of several causes. Verify first that there is no display.

If the display is dark and the green power LED is not lit, proceed with the following tests.

8.5.2 Input Voltage Test

If the drive is equipped with optional equipment, ensure that it is functioning properly. See *chapter 8.4.7 Mains Fuse/DC Fuse Test*, *chapter 8.4.8 Disconnect Test*, *chapter 8.4.9 Circuit Breaker Test*, and *chapter 8.4.10 Contactor Test*.

Input voltage test

1. Apply power to the drive.
2. Use the voltmeter to measure the input mains voltage between the drive input terminals in sequence:
 - L1 to L2
 - L1 to L3
 - L2 to L3

For 380–480 V/380–500 V drives, all measurements must be within the range of 342–550 V AC. Readings of less than 342 V AC indicate problems with the input mains voltage. For 525–690 V drives, all measurements must be within the range of 446–759 V AC. Readings of less than 446 V AC indicate problems with the input mains voltage.

In addition to the actual voltage reading, the balance of the voltage between the phases is also important. The drive can operate within specifications as long as the imbalance of supply voltage is not more than 3%.

Danfoss calculates mains imbalance per an IEC specification.

- $\text{Imbalance} = 0.67 \times (V_{\max} - V_{\min})/V_{\text{avg}}$

For example, if 3-phase readings are taken and the results are 500 V AC, 478.5 V AC, and 478.5 V AC; then 500 V AC is V_{\max} , 478.5 V AC is V_{\min} , and 485.7 V AC is V_{avg} , resulting in an imbalance of 3%.

Although the drive can operate at higher mains imbalances, this condition can shorten the lifetime of some components, such as DC bus capacitors.

Incorrect reading

An incorrect reading here requires further investigation of the main supply. Typical items to check would be:

- Open (blown) input fuses or tripped circuit breakers.
- Open disconnects or line side contactors.
- Problems with the power distribution system.

CAUTION

TEST ORDER

Open (blown) input fuses or tripped circuit breakers usually indicate a more serious problem. Before replacing fuses or resetting breakers, perform static tests described in *chapter 8.4 Static Test Procedures*.

If the input voltage test was successful, check for voltage to the control card.

8.5.3 Basic Control Card Voltage Test

1. Measure the control voltage at terminal 12 in relation to terminal 20. A correct reading is 24 V DC (21–27 V DC).

An incorrect reading can indicate that a fault in the customer connections is loading down the supply. Check the customer connections. Unplug the terminal strip and repeat the test.

2. Measure the 10 V DC control voltage at terminal 50 in relation to terminal 55. A correct reading is 10 V DC (9.2–11.2 V DC).

An incorrect reading can indicate that a fault in the customer connections is loading down the supply. Check the customer connections. Unplug the terminal strip and repeat the test. A correct reading of both control card voltages indicates that the LCP or the control card is defective. Replace the LCP. If the problem persists, replace the control card.

8.5.4 DC Bus Voltage Test

DC bus voltage test part I

1. Using a voltmeter, read the DC bus voltage.
2. In VLT® Parallel Drive Modules, check the voltage at the DC fuse terminals. See *chapter 8.4.7 Mains Fuse/DC Fuse Test* for DC bus location.

Check that the measured voltage is at least 1.35 x the AC input voltage.

Incorrect reading

An incorrect reading can indicate a problem in the inrush circuit, or with the rectifier. See *chapter 8.5.8 Input SCR Test*.

DC bus voltage test part II

1. Power down the drive.
2. Wait for the DC bus to discharge. See the label on the drive or control shelf for discharge times.
3. Remove the control card mounting plate. See *chapter 10.2.2 Control Card and Control Card Mounting Plate*, *chapter 12.3.2 Blank Mounting Plate*, or *chapter 13.2.2 Control Card and Control Card Mounting Plate*.
4. Use an ohmmeter set to measure ohms.
5. Measure between MK902 pin 1 to DC(+).
6. Measure between MK902 pin 2 to DC(-).

A short circuit (0 Ω) is the correct reading for both measurements.

Incorrect reading

An incorrect reading indicates that the wire harness is defective. Replace the wire harness.

DC bus voltage test part III

- In parallel drive systems, remove the common connecting DC terminal to test individual modules (by removing the connecting busbars or DC fuses).
- Measure across fuse F901 on the top of the power card.

An open fuse indicates a failure of a supply on the power card. Replace the power card.

8.5.5 Switch Mode Power Supply Test

The switch mode power supply (SMPS) derives its power from the DC bus. The first indication that the DC bus is charged is the DC bus charge indicator light on the power card being lit. This LED, however, can be lit at a voltage still too low to enable the power supplies.

First test for the presence of the DC bus.

1. Install the signal test board.
2. Install the split bus power supply. Power the power card using split bus mode. See *chapter 9.1.1 Overview*.
3. Connect the negative (-) meter lead to terminal 4 (common) of the signal board. With a positive (+) meter lead, check the following terminals on the signal board.

Terminal	Supply	Voltage range
11	(+)18 V	16.5–19.5 V DC
12	(-)18 V	(-)16.5–19.5 V DC
23	(+) 24 V	23–25 V DC
24	(+) 5 V	4.75–5.25 V DC

Table 8.5 Measured Voltages at Select Terminals

In addition, the signal test board contains 3 LED indicators that show the presence of voltage as follows:

- Red LED (±) 18 V DC supplies present
- Yellow LED (+) 24 V DC supply present
- Green LED (+) 5 V DC supply present

The lack of any of these power supplies indicates that the low voltage supplies on the power card are defective. Replace the power card as described in *chapter 10.2.4 Power Card*, *chapter 11.2.4 Power Card*, or *chapter 13.2.4 Power Card*.

8.5.6 Input Imbalance of Supply Voltage Test

Ideally, all 3 phases have an equal current draw. Some imbalance is possible, however, due to variations in the phase-to-phase input voltage.

A current measurement of each phase reveals the balanced condition of the line. To obtain an accurate reading, it is necessary for the drive to run at more than 40% of its rated load.

1. Perform the input voltage test before checking the current as described in *chapter 8.5.2 Input Voltage Test*. Voltage imbalances automatically result in a corresponding current imbalance.
2. Apply power to the drive and place it in run mode.
3. Using a clamp-on amp meter (analog preferred), read the current on each of 3 input lines at L1(R), L2(S), and L3(T). Typically, the current does not vary from phase to phase by more than 5%. If a greater current variation exists, it indicates a possible problem with the mains supply, or a problem within the drive itself. One way to determine if the mains supply is at fault is to swap 2 of the incoming phases. If all 3 phases are different, swap the phase with the highest current with the phase with the lowest current.
4. Remove power to drive.
5. Swap the phase.
6. Reapply power to the drive and place it in run.
7. Repeat the current measurements.

If the imbalance of supply current moves when swapping the leads, then the mains supply is suspect. Otherwise, there could be a problem with the gating of the SCR, possibly due to a defective SCR/diode module. This result can also indicate a problem in the gate signals from the inrush card to the module. Check the wire harness from the inrush card to the SCR gates. Proceed to testing the input waveform and input SCR in accordance with *chapter 8.5.7 Input Waveform Test* and *chapter 8.5.8 Input SCR Test*.

8.5.7 Input Waveform Test

Testing the current waveform on the input of the drive helps in troubleshooting mains phase loss conditions or suspected problems with the SCR/diode modules. This test easily detects phase loss caused by the mains supply.

The SCR/diode modules control the rectifier section. If an SCR/diode module is defective or the gate signal to the SCR is lost, the drive responds as if losing a phase.

The following measurements require an oscilloscope with voltage and current probes.

Under normal operating conditions, the waveform of a phase of input AC voltage to the drive appears as in *Illustration 8.12*.

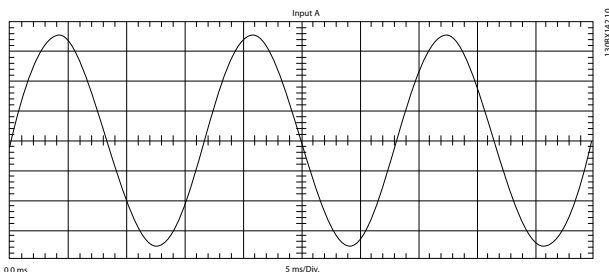

Illustration 8.12 Normal AC Input Voltage Waveform

The waveform shown in *Illustration 8.13* shows the input current waveform for the same phase as in *Illustration 8.12* while the drive is running at 40% load. The 2 positive and 2 negative humps are typical of any 6 diode bridge. It is the same for drives with SCR/diode modules.

The same waveform is seen when measuring a 12-pulse drive between the rectifier and the transformer.

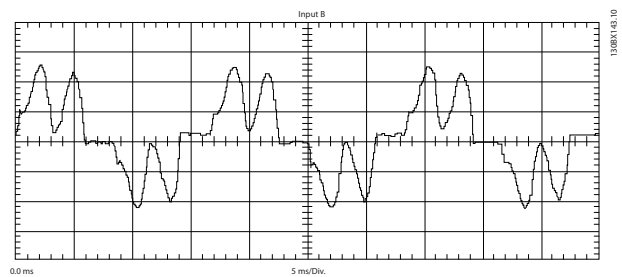

Illustration 8.13 AC Input Current Waveform with Diode Bridge

With a phase loss, the current waveform of the remaining phases resembles *Illustration 8.14*.

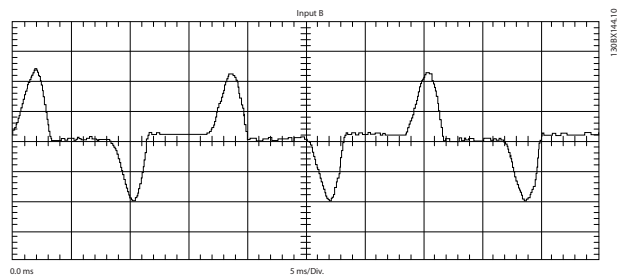

Illustration 8.14 Input Current Waveform with Phase Loss

Always verify the condition of the input voltage waveform before forming a conclusion. The current waveform follows the voltage waveform. If the voltage waveform is incorrect, investigate the reason for the AC supply problem. If the voltage waveform on all 3 phases is correct, but the current waveform is not, then check the input rectifier circuit. Perform the rectifier tests. Refer to *chapter 8.4.1 Rectifier Circuits Test*.

8.5.8 Input SCR Test

The SCRs can be disabled as a result of an input, or lack of input, at power card connector MK106, the external brake temperature switch. Unless used as an input, a jumper must be placed between terminals 104 and 106 of MK106. The following test is to measure the SCR gate resistance.

SCR test part I

1. Remove the power card mounting plate.
2. In D-sized units, unplug inrush board connector MK1802. In E-sized units, unplug inrush board connector MK109.
3. The plug has 3 pairs of wires, 1 for each SCR module. Measure the resistance of each pair. Red is the SCR gate and black is the SCR cathode.

A proper reading is between 5–50 Ω.

A higher reading or an open circuit indicates a failed SCR or a faulty connection.

SCR test part II

1. Check the connections of the gate cables to the SCR/diode modules.
2. If the connections are good, replace the failed SCR/diode module.

If the SCR checks are successful and there is still no DC bus voltage, replace the inrush board.

8.5.9 Output Imbalance of Motor Voltage and Current

Checking the balance of the drive output voltage and current is a way to measure the electrical functioning between the drive and the motor. In testing the phase-to-phase output, both voltage and current are monitored. Conduct static tests on the inverter section of the drive before performing this procedure.

If the voltage is balanced but the current is not, the motor can draw an uneven load. This condition can be the result of:

- A defective motor.
- A poor connection in the wiring between the drive and the motor.
- A defective motor overload, if applicable.

If the output current and the voltage are unbalanced, the drive is not gating the output properly. This condition can be the result of:

- A defective control card.
- A defective power card.
- A defective gate drive card.
- Improper connections between the gate drive card and IGBTs.
- Improper connections in the output circuitry of the drive.

NOTICE

COMPATIBLE VOLTMETERS

Use a PWM-compatible digital or analog voltmeter for monitoring output voltage. Digital voltmeters are sensitive to waveform and switching frequencies and commonly return erroneous readings.

The initial test can be made with the motor connected and running its load. If suspect readings are recorded, disconnect the motor cables to isolate the problem further.

1. Monitor 3 output phases at motor terminals 96 (U), 97 (V), and 98 (W) with the clamp on the ammeter. An analog device is preferred. To achieve an accurate reading, run the drive above 40 Hz, which is normally the frequency limitation of such meters.

A balanced output current from phase to phase is correct. A variation of more than 2–3% is not correct. If the test is successful, the drive is operating normally.

2. Using a voltmeter, measure AC output voltage at motor terminals 96 (U), 97 (V), and 98 (W). Measure phase to phase checking U to V, then U to W, and then V to W.

A variation of more than 8 V AC among the 3 readings is not correct. The actual value of the voltage depends on the speed at which the drive is running. The volts/hertz ratio is relatively linear (except in VT mode) so at 50 Hz/60 Hz the voltage is approximately equal to the mains voltage applied. At 25 Hz/30 Hz, it is about half of that voltage. The exact voltage reading is less important than balance between phases.

If a greater imbalance exists, disconnect the motor cables and repeat the voltage balance test.

Since the current follows the voltage, it is necessary to differentiate between a load problem and a drive problem. If a voltage imbalance in the output occurs with the motor disconnected, test the gate drive circuit for proper firing. Proceed to *chapter 8.5.10 IGBT Switching Test*.

If the voltage was balanced but the current imbalanced when the motor was connected, then the load is suspect. There could be a faulty connection between the drive and motor or a defect in the motor itself. Look for bad connections at any junctions of the output wires including connections made to contactors and overloads. Also, check for burned or open contacts in such devices.

8.5.10 IGBT Switching Test

⚠WARNING

DISCHARGE TIME

The drive contains DC-link capacitors, which can remain charged even when the drive is not powered. High voltage can be present even when the warning LED indicator lights are off. Failure to wait the specified time after power has been removed before performing service or repair work can result in death or serious injury.

- Stop the motor.
- Disconnect AC mains and remote DC-link power supplies, including battery back-ups, UPS, and DC-link connections to other drives.
- Disconnect or lock the motor.
- Disconnect any brake option.
- Disconnect any regen/load share option.
- Wait for the capacitors to discharge fully. The minimum waiting time is specified in the following discharge time table and is also visible on the drive label.
- Before performing any service or repair work, use an appropriate voltage measuring device to make sure that the capacitors are fully discharged. For parallel drive modules, measure DC-bus capacitor voltages before and after the individual DC fuses.

Enclosure Size	Minimum waiting time
D1h–D8h drives	20 minutes
J8–J9 drives	20 minutes
D9h–D10h enclosed drive systems	20 minutes
Da2/Da4/Db2/Db4 parallel drive systems	20 minutes
E1h–E4h drives	40 minutes
E5h–E6h enclosed drive systems	40 minutes

Table 8.6 Discharge Time

To determine whether the IGBTs are switching correctly, use the following procedure.

1. Connect the split bus power supply. See *chapter 9.1.1 Overview*.
2. Switch on the 650 V DC supply and 24 V DC supply.
3. Apply a run command and speed command of approximately 40 Hz.
4. Measure the phase-to-phase output waveform on all 3 output phases of the drive using an oscilloscope (preferred) or a voltmeter.
 - 4a When measuring with an oscilloscope, the waveform appears the same as in normal operation, except that the amplitude is 24 V peak. See *Illustration 8.15*
 - 4b When measuring with a voltmeter set to read AC voltage, the meter reads approximately 17 V AC on all 3 phases. Differences in drive settings can cause a slight variation in this reading, but it is important that the readings are equal on all 3 phases.

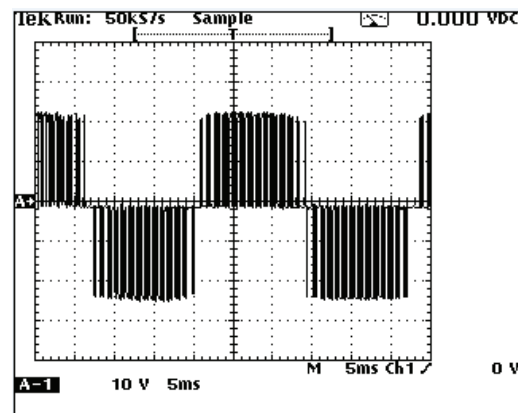

Illustration 8.15 Output Wave Form

An incorrect reading indicates either a defective IGBT or gate drive signal. To determine if the gate drive signal is correct, perform the gate drive signal test. See *chapter 8.5.11 IGBT Gate Drive Signals Test*.

8.5.11 IGBT Gate Drive Signals Test

NOTICE

DRIVE TYPE

This test is applicable to only D-sized drives. E1h–E4h drives do not have test connectors on the gate drive card.

This procedure tests the gate drive signals at the output of the gate drive card just before they are delivered to the IGBTs. A simple test to check for the presence of the gate signals can be performed with a voltmeter. To check the waveforms more precisely, however, an oscilloscope is required.

NOTICE

POTENTIAL PIN DAMAGE

Disable the DC bus when performing this test with split bus power supply. Failure to do so can result in damage to the drive if the probe is inadvertently connected to the wrong pins.

Before beginning the tests, ensure that power is removed from the unit and that the DC bus capacitors have fully discharged.

Install the split bus power supply.

1. Remove the AC busbars or RFI filter (option).
2. Connect the split bus power supply. Refer to *chapter 9.1.1 Overview*.

In D-sized drives, there is a 3-pin test connector on the gate drive card near each gate signal lead. Refer to *Illustration 8.8*. These leads are labeled:

- MK500
- MK502
- MK600
- MK602
- MK700
- MK702
- MK200 (if equipped with a brake option)

See *Illustration 8.8*.

Refer to the 3 pins as 1, 2, and 3, reading bottom to top. Pins 1 and 2 of each connector are in parallel with the gate drive signal sent to the IGBTs. Pin 1 is the signal and pin 2 is common.

1. Turn on the split bus power supply (only 650 V).
2. In stop mode, measure pins 1 and 2 of each test connector. A correct reading is approximately -9 V DC, which indicates that all IGBTs have been turned off.
3. Apply the run command to the drive and 30 Hz reference.
4. If using a voltmeter, measure pins 1 and 2 of each connector. Waveform to IGBTs is a square wave that goes positive to 14 V DC and negative to -9 V DC. Average voltage read by the voltmeter is 2.2–2.5 V DC.

When using an oscilloscope, the readings in *Illustration 8.16* are correct.

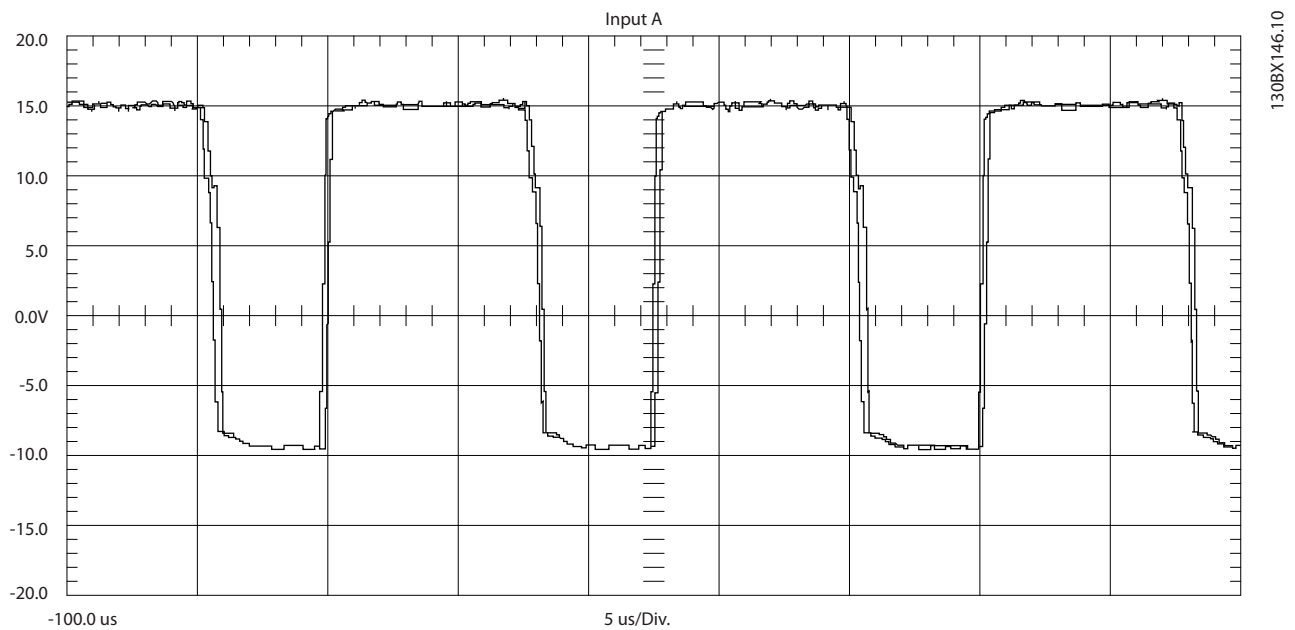

Illustration 8.16 Gate Signal Waveform from Gate Drive Card

IGBT gate signal measured on the gate drive card: 5 V per division vertical scale, 50 ms per division time scale. Unit running at 30 Hz.

An incorrect reading of a gate signal indicates that the gate drive card is defective or the signal has been lost before arriving at the gate card. The gate signals can then be checked with the signal test board to verify their presence from the control card to the power card as follows.

1. Insert the signal test board into power card connector MK104.
2. With scope probe common connected to terminal 4 (common) of the signal board, measure 6 gate signals at signal board terminals 25–30.
3. Place the drive in run mode at 30 Hz.

The waveform in *Illustration 8.17* is the correct result.

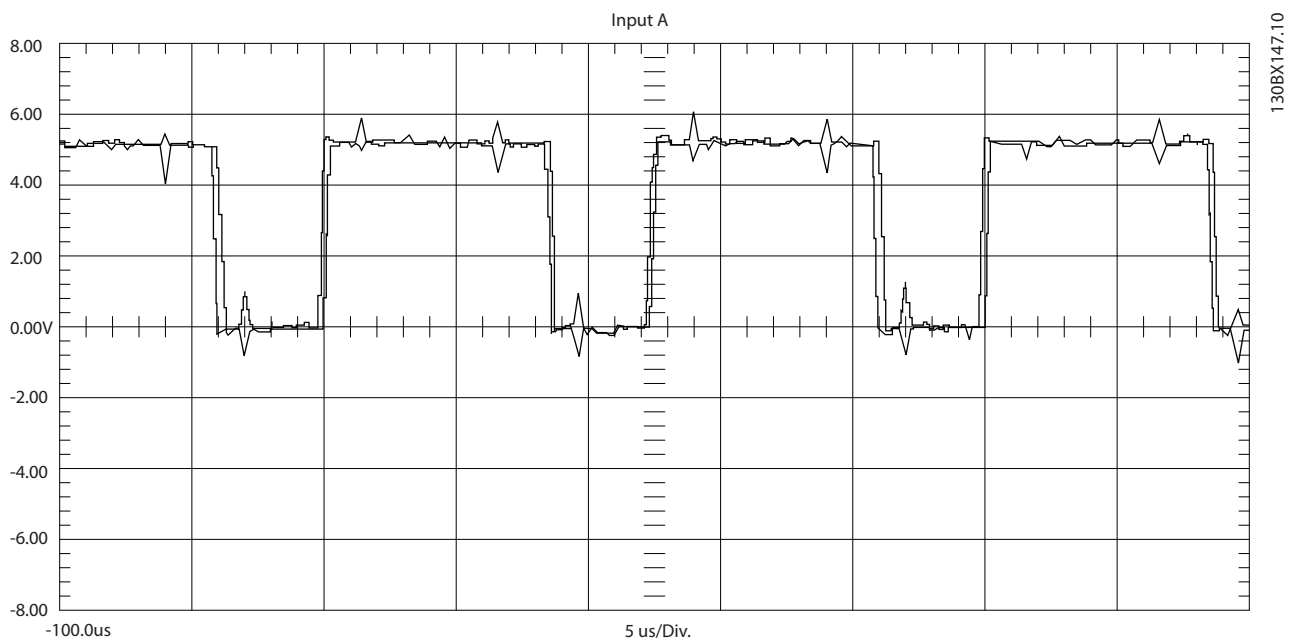

Illustration 8.17 Gate Signal Waveform from Signal Test Board

IGBT gate signal measured with the signal test board: 2 V per division vertical scale, 50 ms per division time scale. Unit running at 30 Hz.

4. Using a voltmeter, again check these same signal board terminals. A correct reading is 2.2–2.5 V DC.

An incorrect reading of a gate signal indicates that the control card is defective. Replace the control card.

If the signal is good on the signal test card, but missing on the gate drive card, the failure can be due to:

- The gate drive card.
- The power card.
- The ribbon cable between them.

Replace the gate drive board and repeat the test.

8.5.12 Current Sensors Test

The current sensors are Hall effect devices that send a signal proportional to the actual output current waveform to the power card. The current scaling card scales the signals from the current sensors to the proper level for monitoring and processing motor control data. A defective current sensor can cause erroneous ground faults and overcurrent trips. In these instances, the faults occur only at higher loads. If the incorrect current scaling card is installed, the current signals are not scaled properly. Incorrect scaling could cause erroneous overcurrent trips. If the current scaling card is not installed, the drive trips.

In D1h–D8h and E1h–E4h units, the current scaling card is found on the power card. In parallel drive systems, the current scaling card is found on the MDCIC card on the control shelf.

To determine the status of the sensors, use the following tests.

If the control card parameters are set to provide holding torque at 0 speed, the current shown is greater than expected. To perform the sensor tests, disable these parameters.

1. Apply power to the drive.
2. Ensure that the following parameter settings are disabled:
 - Motor check
 - Premagnetizing
 - DC hold
 - DC brake
 - Any others that create a holding torque while at 0 speed.
3. Run the drive with a 0 speed reference and check the output current reading in the display. A correct reading is approximately 1–2 A. If these parameters are not disabled, the current shown exceeds 1–2 A.

If the current is greater than 1–2 A and no current-producing parameters are active, run the following test:

1. Remove power from the drive.
2. Remove the output motor cables from terminals U, V, and W.
3. Apply power to the drive.
4. Run the drive with a 0 speed reference, and check the output current reading in the display. A correct reading is less than 1 A.

If these tests result in incorrect readings, perform the following test of the current feedback signals using the signal test board:

1. Remove power to the drive. Make sure that the DC bus is fully discharged.
2. Connect the signal test board to power card connector MK104.
3. Using an ohmmeter, measure the resistance between terminals 1 and 4, 2 and 4, and 3 and 4 of the signal test board. The correct resistance is an identical reading on all 3 terminals.
4. Reapply power to the drive.
5. Using a voltmeter, connect the negative (-) meter lead to terminal 4 (common) of the signal test board.
6. Run the drive with a 0 speed reference.
7. Measure the AC voltage in sequence at terminals 1, 2, and 3 of the signal test board. These terminals correspond with current sensor outputs U, V, and W, respectively. Expect a reading near 0 V, and no greater than 15 mV.

The current sensor feedback signal in the circuit reads approximately 400 mV at a drive load of 100%. When the drive is at 0 speed, any reading above 15 mV negatively impacts the way the drive interprets the feedback signal.

Replace the corresponding current sensor if the reading is greater than 15 mV.

Table 8.8 and Table 8.9 list approximate resistance readings for individual D-sized units based on power and voltage rating, and the current scaling card. Table 8.10 through Table 8.13 list approximate resistance readings for parallel drive systems based on power and voltage rating, and the current scaling card. When measuring with the signal test board, the reading could be higher due to meter lead resistance. A reading of no resistance indicates a missing scaling card.

Scaling resistance measured in Ω	Model	
	FC 102, FC 103, and FC 202	FC 302
3.8	N55K	N45K
3.1	N75K	N55K
2.6	N90K	N75K
2.6	N110	N90K
5.1	N150	N110
4.2	N160	N150

Table 8.7 Scaling Resistance, D1h–D4h Units, 200–240 V

Scaling resistance measured in Ω	Model	
	FC 102, FC 103, and FC 202	FC 302
4.6	N110	N90k
3.8	N132	N110
3.1	N160	N132
2.6	N200	N160
5.1	N250	N200
4.2	N315	N250

Table 8.8 Scaling Resistance, D1h–D8h Units, 380–480/500 V

Scaling resistance measured in Ω	Model	
	FC 102, FC 103, and FC 202	FC 302
5.9	N75k	N55k
5.9	N90k	N75k
5.9	N110	N90k
5.9	N132	N110
5.0	N160	N132
4.0	N200	N160
3.2	N250	N200
2.7	N315	N250
5.6	N400	N315

Table 8.9 Scaling Resistance, D1h–D8h Units, 525–690 V

Scaling resistance measured in Ω	Model		Drive modules
	FC 102, FC 103, and FC 202	FC 302	
4.2	N500	N450	2-module system
2.6	N560	N500	4-module system
5.1	N630	N560	4-module system
5.1	N710	N630	4-module system
4.2	N800	N710	4-module system
4.2	N1M0	N800	4-module system

Table 8.10 Scaling Resistance, Parallel Drive Systems, 6-pulse, 380–500 V

Scaling resistance measured in Ω	Model		Drive modules
	FC 102, FC 103, and FC 202	FC 302	
5.6	N630	N560	2-module system
3.2	N710	N630	4-module system
2.7	N800	N710	4-module system
2.7	N900	N800	4-module system
5.6	N1M0	N900	4-module system
5.6	N1M2	N1M0	4-module system

Table 8.11 Scaling Resistance, Parallel Drive Systems, 6-pulse, 525–690 V

Scaling resistance measured in Ω	Model		Drive modules
	FC 102, FC 103, and FC 202	FC 302	
2.6	N315	N250	2-module system
5.1	N355	N315	2-module system
5.1	N400	N355	2-module system
4.2	N450	N400	2-module system
4.2	N500	N450	2-module system
2.5	N560	N500	4-module system
5.1	N630	N560	4-module system
5.1	N710	N630	4-module system
4.2	N800	N710	4-module system
4.2	N1M0	N800	4-module system

Table 8.12 Scaling Resistance, Parallel Drive Systems, 12-pulse, 380–500 V

Scaling resistance measured in Ω	Model		Drive modules
	FC 102, FC 103, and FC 202	FC 302	
4.0	N315	N250	2-module system
3.2	N400	N315	2-module system
3.2	N450	N355	2-module system
2.7	N500	N400	2-module system
5.6	N560	N500	2-module system
5.6	N630	N560	2-module system
3.2	N710	N630	4-module system
2.7	N800	N710	4-module system
2.7	N900	N800	4-module system
5.6	N1M0	N900	4-module system
5.6	N1M2	N1M0	4-module system

Table 8.13 Scaling Resistance, Parallel Drive Systems, 12-pulse, 525–690 V

Scaling resistance measured in Ω	Model	
	FC 102, FC 103, and FC 202	FC 302
2.7	N355	N315
2.5	N400	N355
2.3	N450	N400
2.0	N500	N450
1.8	N560	N500

Table 8.14 Scaling Resistance, E1h–E4H Units, 380–500 V

Scaling resistance measured in Ω	Model	
	FC 102, FC 103, and FC 202	FC 302
4.0	N450	N355
3.8	N500	N400
3.1	N560	N500
2.7	N630	N560
2.5	N710	N630
2.1	N800	N710

Table 8.15 Scaling Resistance, E1h–E4h Units, 525–690 V

8.5.13 Fan Tests

All fan tests can be performed with the unit powered from the AC mains or with the power card powered in split bus mode. Any time a fan is commanded to start, the control card checks the fan feedback signal. If the feedback is missing, the drive issues an alarm or warning based on which fan feedback is missing.

In E-sized drives, there are parameters that show the speed feedback for each fan. Fan speed differences of less than 200 RPM are meaningless.

- *Parameter 43-13 PC Fan A Speed* for input plate mixing fan.
- *Parameter 43-14 PC Fan B Speed* for left input plate mixing fan or power card mixing fan.
- *Parameter 43-20 FPC Fan A Speed* for left heat sink fan.
- *Parameter 43-21 FPC Fan B Speed* for the middle heat sink fan.
- *Parameter 43-22 FPC Fan C Speed* for the right heat sink fan.
- *Parameter 43-24 FPC Fan E Speed* for LCP side door fan.
- *Parameter 43-25 FPC Fan F Speed* for lock side door fan.

NOTICE

POWER REQUIREMENTS

The split bus power supply must have sufficient power when testing E1h–E4h drives. Fan load in E-sized drives is >700 W.

Mixing fan

In D-sized drives, the mixing fan operates any time the drive is powered up. If the drive is powered and the mixing fan is not running, replace the mixing fan.

In E-sized drives, the operation of the mixing fan is controlled and only runs when commanded.

Heat sink and door/top fans

Parameter 14-52 Fan Control can be used to command the fans to run at 100% speed.

1. Use *parameter 14-52 Fan Control* to command the fans to run at 100% speed.
2. Confirm that the heat sink fan is running by checking for airflow through the back channel of the drive.
3. Confirm that the door/top fan is running by checking for airflow around the fan.

The 2 fans accelerate at different rates and can take several seconds, but both operate at 100% speed.

Incorrect reading

If neither fan is running, the most likely cause is that the fan control circuit on the power card (or fan power card in E-sized drives) is faulty. Replace the power card or fan power card. If only 1 fan is running, the most likely cause is that the other fan is faulty. Replace the failed fan.

8.5.14 Input Terminal Signal Tests

The presence of signals on either the digital or analog input terminals of the drive can be verified on the drive display. *Parameter 16-60 Digital Input* – *parameter 16-64 Analog Input 54* show the status for the standard inputs. Other parameters show the status of option inputs.

Digital inputs

View the digital inputs by using *parameter 16-60 Digital Input*. The status of control terminals 18, 19, 27, 29, 32, and 33 are shown (left to right) with terminal 33 on the right of the display. A 1 indicates the presence of a signal, which means the logic is true and the input is on.

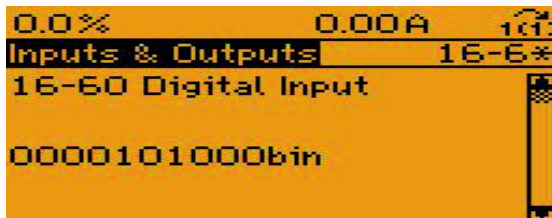

130BB038.10

Illustration 8.18 Digital Inputs Display

If the display does not show the correct signal, investigate the following:

- External control wiring to the drive
- Incorrect programming of *parameter 5-00 Digital I/O Mode*
- Faulty control card

Use *parameter 5-00 Digital I/O Mode* to program the digital inputs to either accept a sourcing output (PNP) or a sinking output (NPN). When programmed for PNP (factory default), the digital input turns on when 24 V DC is applied to the digital input terminal. When programmed for NPN, the digital input turns on when the terminal is connected to signal common (terminal 20).

The power for the digital inputs can either come from the (+) 24 V DC built into the drive, or from an external supply. If an external supply is used, reference the common of the supply to terminal 20.

Check for an internal power supply

1. Connect the (-) negative meter lead to terminal 20.
2. Connect the (+) positive meter lead to terminal 12 or terminal 13 and measure the DC voltage.

A correct reading is 21–27 V DC. If the supply voltage is not present, perform the basic control card voltage test. See *chapter 8.5.3 Basic Control Card Voltage Test*.

Check the individual inputs if *parameter 5-00 Digital I/O Mode* is PNP

1. Connect the (-) negative meter lead to terminal 20.
2. Connect the (+) positive meter lead to each digital input in sequence and measure the DC voltage.

The correct display for each digital input where the voltage reading is greater than 10 V DC is 1. The correct display for each digital input where the voltage reading is less than 5 V DC is 0. If the display does not correspond with the measured inputs, the digital inputs on the control card have failed. Replace the control card.

Check the individual inputs if *parameter 5-00 Digital I/O Mode* is NPN

1. Connect the (-) negative meter lead to terminal 20.
2. Connect the (+) positive meter lead to each digital input in sequence and measure the DC voltage.

The correct display for each digital input where the voltage reading is less than 14 V DC is 1. The correct display for each digital input where the voltage reading is greater than 19 V DC is 0. If the display does not correspond with the measured inputs, the digital inputs on the control card have failed. Replace the control card.

Analog inputs

Terminals 53 and 54 are the standard analog input terminals. Each terminal can be configured as a voltage input or a current input. Switch S201 on the control card configures terminal 53. Switch S202 configures terminal 54.

Use *parameter 16-62 Analog Input 53* to show the value on terminal 53 and *parameter 16-64 Analog Input 54* to show the value on terminal 54.

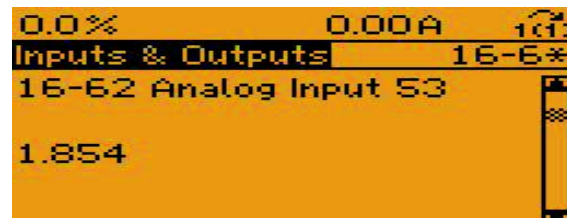

130BB039.10

Illustration 8.19 Analog Inputs Display

Incorrect signals indicate problems in the external control wiring to the drive, configuration of the switches, or a faulty control card.

The power for the analog inputs either comes from the supply built into the drive, or from an external supply. If an external supply is used, reference the common of the supply to terminal 55.

Verify the control voltage supply

1. Connect the (-) negative meter lead to terminal 55.
2. Connect the (+) positive meter lead to terminal 50.

The correct reading is 9.2–11.2 V DC. If the supply voltage is not present, perform the basic control card voltage test.

Verify that the analog input is configured for the type of signal being sent to the drive. *Parameter 16-61 Terminal 53 Switch Setting* shows the configuration of terminal 53, and *parameter 16-63 Terminal 54 Switch Setting* shows the configuration of terminal 54. If the inputs are not configured correctly, power down the drive and change switches S201 and S202.

Check the individual inputs if configured for voltage

1. Connect the (-) negative meter lead to terminal 55.
2. Connect the (+) positive meter lead to terminal 53 or terminal 54 and measure the DC voltage.

For each analog input, the measured DC voltage must match the value shown in the display parameter. If the display does not correspond with the measured input and the switch is configured for voltage, the analog input on the control card has failed. Replace the control card.

Check the individual inputs if configured for current

1. Connect the (-) negative meter lead to terminal 55.
2. Connect the (+) positive meter lead to terminal 53 or terminal 54 and measure the DC voltage.

When configured for current, the current flows through a 200 Ω resistor to create a voltage drop. A 4 mA current flow creates approximately a 0.8 V DC voltage reading. A 20 mA current flow creates approximately a 4.0 V DC voltage reading. The display shows the mA value. If the display does not correspond with the measured input, the analog input on the control card has failed. Replace the control card.

Incorrect reading

A negative voltage reading indicates a reversed polarity. Reverse the wiring to the analog input.

8.6 After-repair Tests

▲WARNING

DISCHARGE TIME

The drive contains DC-link capacitors, which can remain charged even when the drive is not powered. High voltage can be present even when the warning LED indicator lights are off. Failure to wait the specified time after power has been removed before performing service or repair work can result in death or serious injury.

- Stop the motor.
- Disconnect AC mains and remote DC-link power supplies, including battery back-ups, UPS, and DC-link connections to other drives.
- Disconnect or lock the motor.
- Disconnect any brake option.
- Disconnect any regen/load share option.
- Wait for the capacitors to discharge fully. The minimum waiting time is specified in the following discharge time table and is also visible on the drive label.
- Before performing any service or repair work, use an appropriate voltage measuring device to make sure that the capacitors are fully discharged. For parallel drive modules, measure DC-bus capacitor voltages before and after the individual DC fuses.

Enclosure Size	Minimum waiting time
D1h–D8h drives	20 minutes
J8–J9 drives	20 minutes
D9h–D10h enclosed drive systems	20 minutes
Da2/Da4/Db2/Db4 parallel drive systems	20 minutes
E1h–E4h drives	40 minutes
E5h–E6h enclosed drive systems	40 minutes

Table 8.16 Discharge Time

8.6.1 After-repair Tests for D-sized and E-sized Drives

Following testing or repair of a unit, use these steps to ensure that all circuitry is functioning properly before putting the unit into operation.

1. Perform visual inspection procedures as described in *chapter 6.4 Visual Inspection*.
2. Perform static test procedures to ensure that the unit is safe to start.
3. Disconnect motor cables from output terminals (U, V, W).
4. Apply AC power to the unit.
5. Give the unit a run command and slowly increase reference (speed command) to approximately 40 Hz.
6. Using an analog voltmeter or a DVM capable of measuring true RMS, measure phase-to-phase output voltage on all 3 phases: U to V, U to W, V to W. All voltages must be balanced within 8 V. If unbalanced voltage is measured, refer to *chapter 8.5.2 Input Voltage Test*.
7. Stop the unit and remove input power. Allow DC capacitors to discharge fully.
8. Reconnect motor cables to the output terminals (U, V, W).
9. Reapply power and restart the unit. Adjust the motor speed to a nominal level.
10. Using a clamp-on style ammeter, measure output current on each output phase. All currents must be balanced.

8.6.2 After-repair Tests for Parallel Drive Systems

Following testing or repair of a unit, use these steps to ensure that all circuitry is functioning properly before putting the unit into operation.

1. Perform visual inspection procedures as described in *chapter 6.4 Visual Inspection*.
2. Perform static test on the drive as described in *chapter 8.4 Static Test Procedures*.
3. Remove the 3 output motor busbars from each module.
4. Connect a 610–800 V DC supply to the SMPS input for each module using the test cable (176F8766). (Preferably, use a Danfoss split bus power supply.)
5. Apply power to the split bus power supply and check that the LCP lights properly. The fans do not operate when powered in this manner.

6. Give the drive a run command (press [Hand on]) and slowly increase the reference (speed command) to approximately 40 Hz.
7. Using the signal test board (176F8437) and an oscilloscope, check the waveform at pins 25–30 with the scope referenced to pin 4. This procedure must be performed on each inverter module. Each waveform must approximate the example in *Illustration 8.20*.
8. Connect a 24 V DC supply to the DC bus of the drive. Preferably, use a Danfoss split bus power supply. Connect it to the DC bus output of the module, or to the busbars connecting the top of the DC fuses on any module.
9. Observe the phase-to-phase waveform on the motor busbars of each phase of each inverter module. Compare the waveform to the normal output waveform of a properly operating drive. Check that the waveforms are similar, except that the amplitude is 24 V instead of the full output voltage.
10. Press [OFF] on the LCP.
11. Disconnect power from both supplies and reinstall jumper connectors to the SMPS input plugs on all modules.
12. Reinstall the motor busbars on all modules.
13. Apply AC power to the drive.
14. Apply a start command to the drive. Adjust the speed to a nominal level. Observe that the motor is running properly.
15. Using a clamp-on style current meter, measure the output current on each phase. All currents must be balanced.

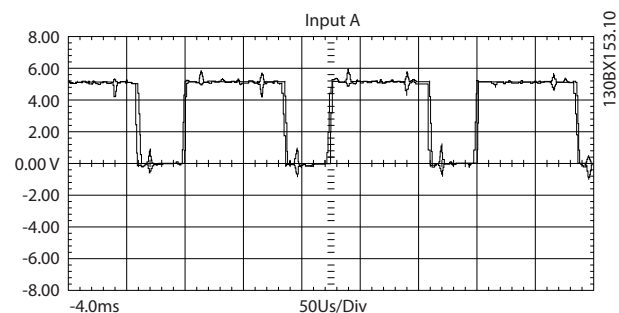

Illustration 8.20 System Test Waveform: 2 V/div 100us/div Run at 10 Hz

9 Special Test Equipment

Special test tools have been developed to aid in troubleshooting Danfoss products. The tools are required to perform some of the testing procedures outlined in this guide. The following test equipment described in this section is available from Danfoss.

- Split bus power supply (p/n 130B3146)
- Parallel drive module service kit (p/n 176F3745)
- Signal test board (p/n 176F8437)

9.1 Split Bus Power Supply

9.1.1 Overview

In split bus mode, the DC bus is split into 2 parts. One part powers the SMPS on the power card, allowing the various logic circuits to be tested without the risk of damaging the power components.

The other part can be used to provide low voltage power to the DC capacitors and output IGBTs for test purposes. A low voltage supply connected to the DC bus allows safe testing of the output.

9.1.2 Split Bus Power Supply Diagrams

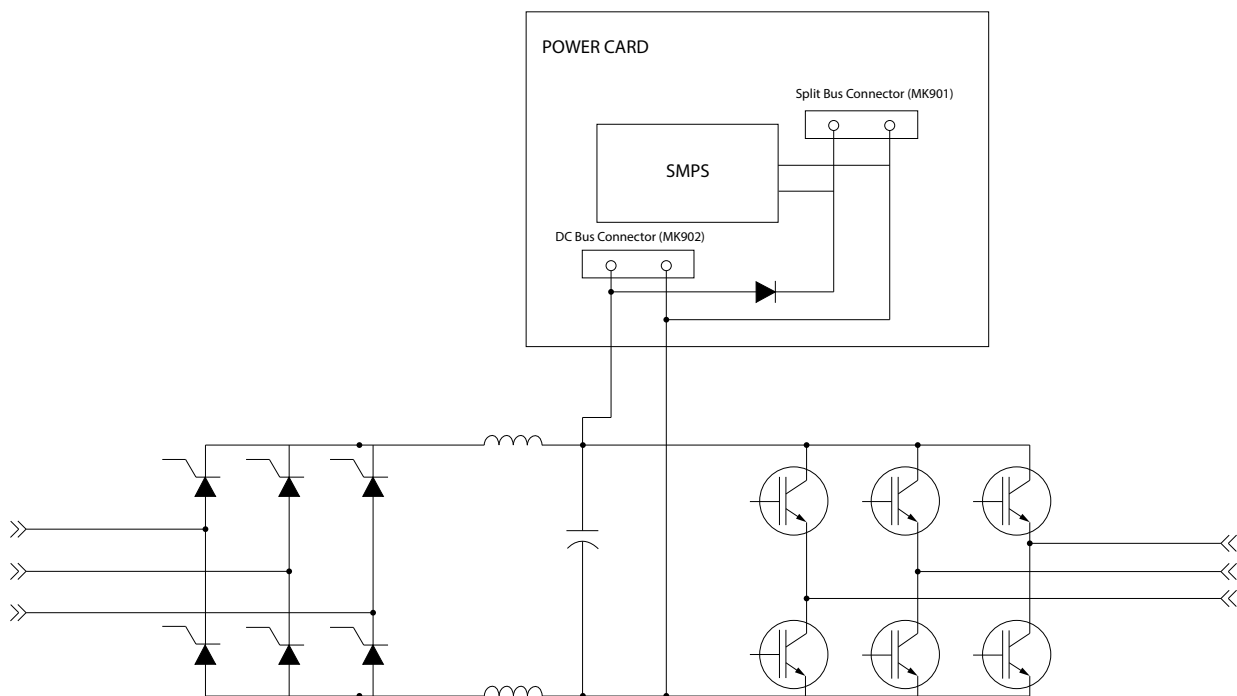

130BF084.10

Illustration 9.1 Connection at Normal Condition

130BF085.10

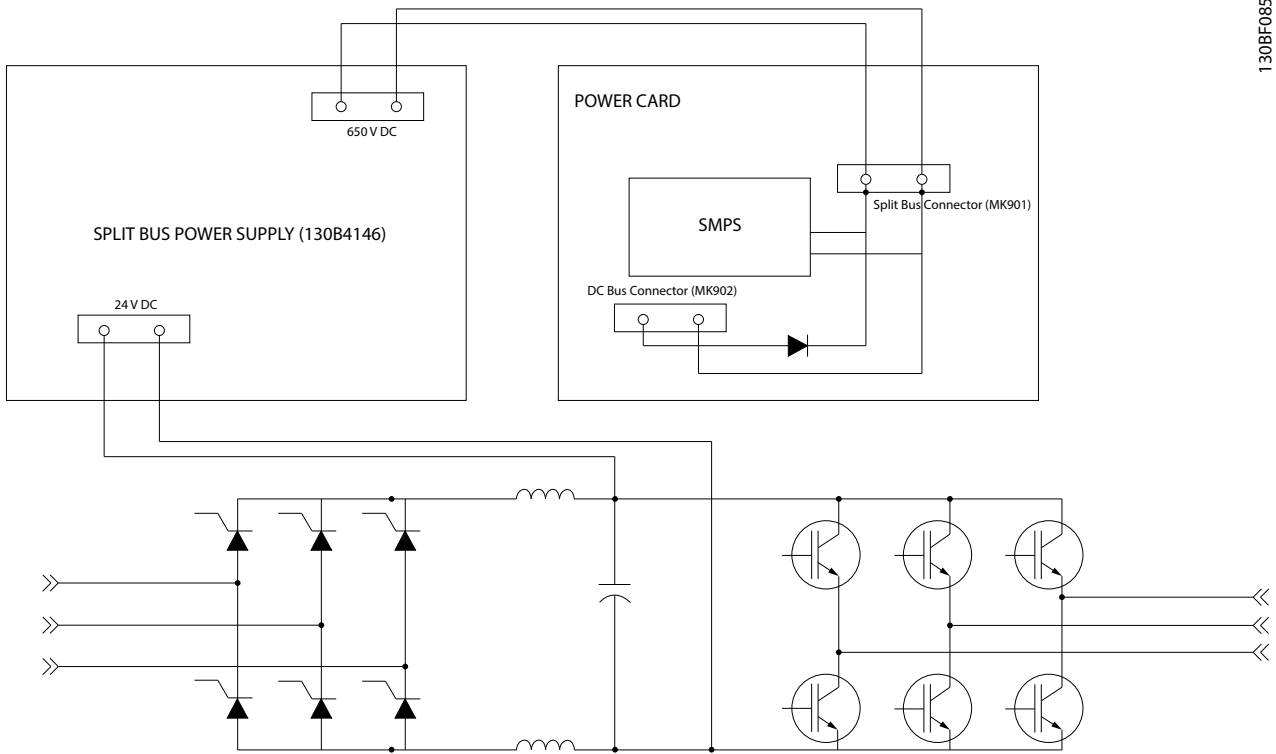

Illustration 9.2 Connection During Split Bus Mode for a Single Drive

9

130BF086.10

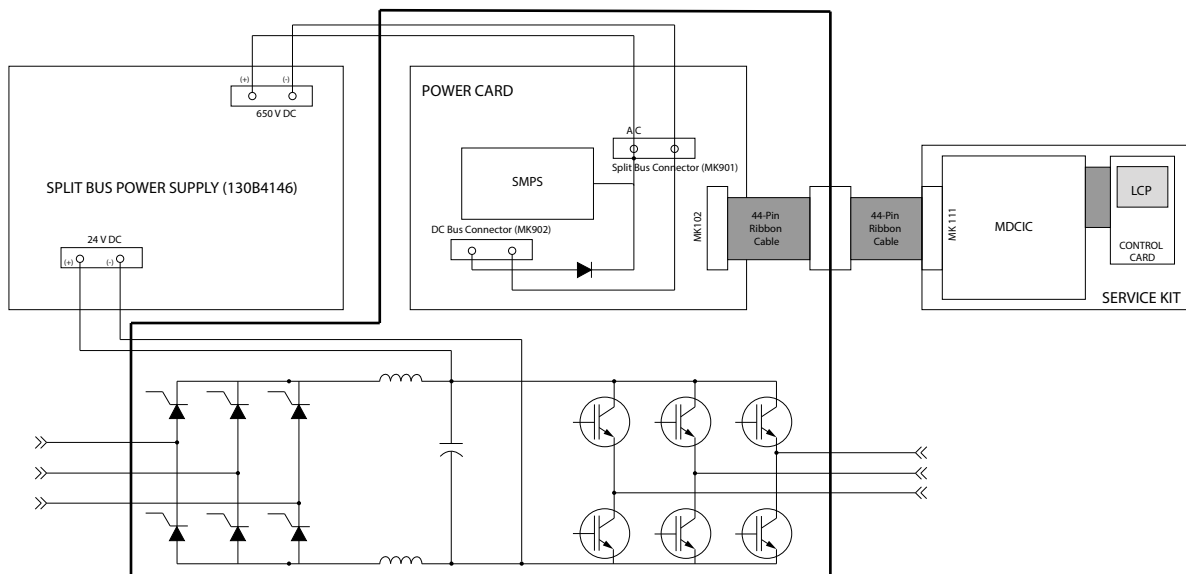

Illustration 9.3 Connection During Split Bus Mode in Parallel Drive

9.1.3 Split Bus Power Supply Connection

⚠ WARNING

PERSONAL INJURY RISK

Do not apply AC mains voltage to the drive when it is wired in split bus mode.

NOTICE

PARALLEL DRIVE MODULE CONNECTION

If servicing an individual module from a parallel drive system, an external service kit is required during split bus power mode. See *chapter 9.2.1 Overview* for instructions.

Connecting the Split Bus Power Supply to a Single Drive

1. Ensure that AC power has been removed and all DC capacitors are fully discharged.
2. Remove the top and bottom shields for access to the busbars and terminals.
3. Remove the control card mounting plate for access to the power card.
4. Disconnect the DC link plug from connector MK902 on the power card.
5. Connect a DC supply to the split bus terminal (MK901 or MK 902) on the power card. If using MK 901, pin A is positive and pin C is negative. If using MK902, pin 1 is positive and pin 4 is negative. To run all the fans at 100% on split bus power supply, the minimum current rating required is 1500 mA. The allowable power supply range depends on the voltage of the drive:
 - 230 V AC drive (T2) requires 210–380 V DC supply.
 - 400 V AC drive (T4/T5) requires 420–750 V DC supply.
 - 690 V AC drives (T7) requires 610–1000 V DC supply.

The Danfoss split bus power supply (p/n 130B3146) is designed to provide 650 V DC,

which is compatible with 400 V AC and 690 V AC drives.

6. Reinstall the control card mounting plate.
7. Apply the voltage to the unit. The LCP indicator lights illuminate as if the drive was powered normally.

9.2 Parallel Drive Module Service Kit

9.2.1 Overview

The parallel drive module service kit allows authorized technicians to run and test an individual parallel drive module when it is not installed in a system. For example if a single parallel drive module in a 4-module system fails, the failed module is removed and serviced. Before the technician reinstalls the repaired module into the 4-module configuration, the technician tests the module using this service kit.

The service kit enables the technician to:

- Troubleshoot and test an individual parallel drive module in split bus mode.
- Program an individual drive module.
- Check the logic connections of an individual drive module using the 24 V option D card.

Components of the service kit

- LCP.
- Control card.
- MDCIC.
- Wire harness to connect MDCIC to control card.
- Wire harness to connect MDCIC to module.
- 24 V power supply option card (optional).

Tools required

- Wire harness for powering 24 V option card.
- 230 V to 24 V rectifier (if 24 V DC is not available in field).
- Current scaling card for the appropriate module.
- Tools for opening the service kit enclosure.
- Split bus power supply.

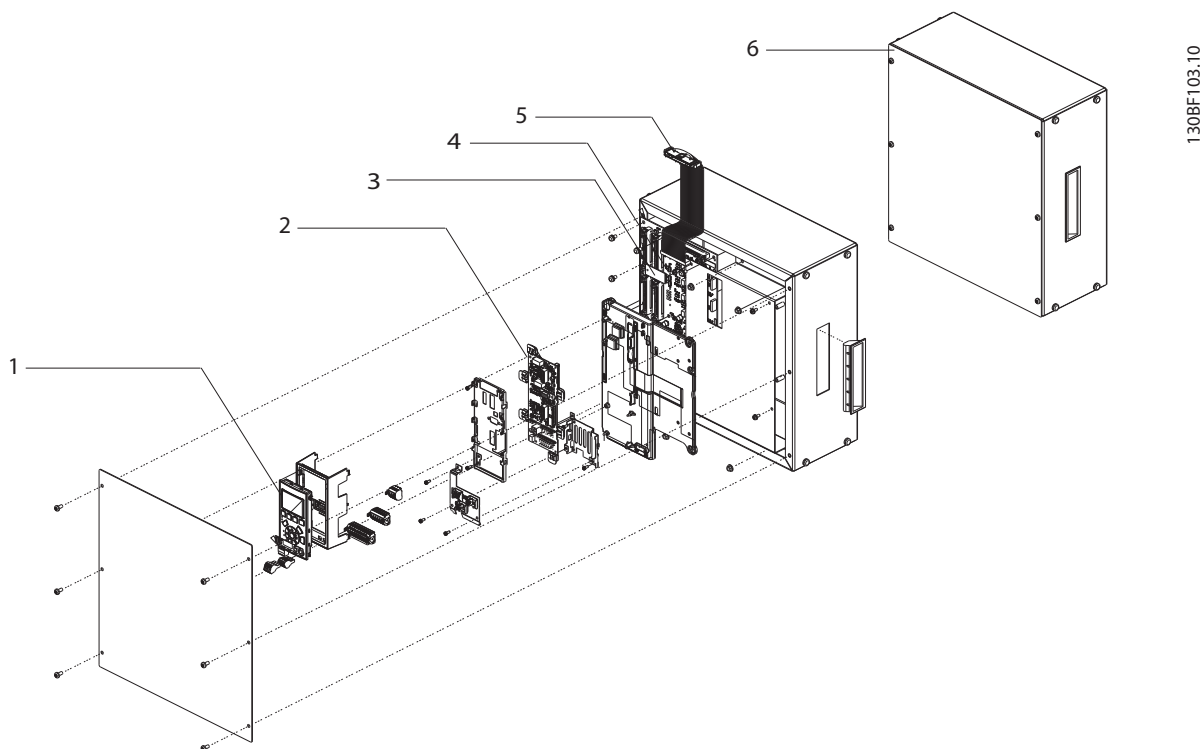

1	LCP	4	MDCIC
2	Control card	5	Cable connector (test kit to drive module)
3	Current scaling card	6	Assembled service kit

Illustration 9.4 Parallel Module Service Kit

9

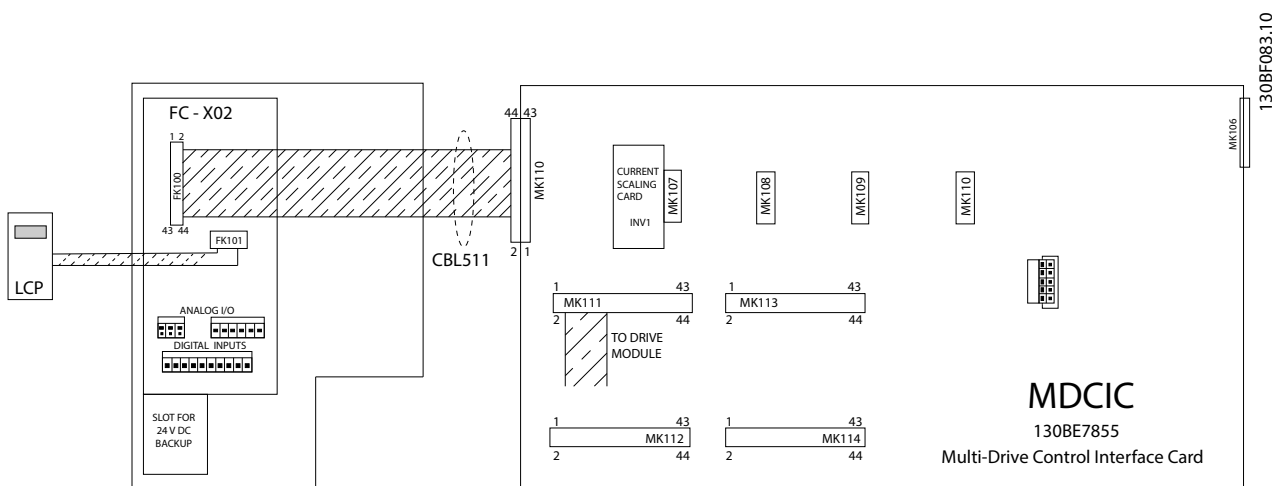

Illustration 9.5 Service Kit Internal Connection Diagram

Because the control card and current scaling card are not located within the individual module, but are on the control shelf, the module cannot run without being connected to the service kit. The service kit includes an MDCIC and other components required to run an individual drive module outside of the parallel drive system.

9.2.2 Split Bus Power Supply and Parallel Drive Modules

NOTICE

LOAD CONDITIONS

Use the following procedures for parallel drive module testing with split bus or no load conditions. Do not use these procedures under load conditions. Using the procedures for load conditions can lead to parallel drive module failure.

After isolating the failed parallel drive module from the parallel system, use the following procedures to run the parallel drive module as a standalone unit.

Running a parallel drive module (with replaced power card)

For parallel drive modules with a failed power card, use the following procedure to run the module in standalone mode. If the power card has not failed, skip to the next procedure.

1. Place the new power card in the drive module and ensure that all screws are tightened properly.
2. Connect the 44-pin ribbon cable from the MDCIC in the service kit to the connector on the top of the module.
3. Attach the current scaling card to the MK101 connector on the service kit MDCIC. (See *chapter 15.1.3 Recommended Current Scaling Cards* for current scaling card part numbers.)
4. Connect the current scaling card to master drive slot (inverter1) on MDCIC.
5. Unplug the DC link connector (MK902) from the power card of the drive module.
6. Connect the 650 V DC connector from the split bus power supply to the split bus connector (MK901) of the power card.
7. Connect the DC bus supply cable from the split bus power supply (24 V DC) to the DC link connector (MK902).
8. Apply power to the split bus power supply.
9. Check the display on the LCP. *Alarm 250, New spare part* appears.
10. Enter the appropriate type code for the module as listed in *Table 9.1*.
11. Save the setting to EEPROM.
12. Power cycle the drive module. The module is initialized in standalone mode and is ready for testing as described in *chapter 8 Test Procedures*.

Running a parallel drive module in standalone mode

After isolating the failed parallel drive module from the parallel system, use the following procedure to run the parallel drive module as a standalone unit. If the unit has a failed power card, use the previous procedure.

1. Connect the 44-pin ribbon cable from the MDCIC in the service kit to the connector on the top of the module.
2. Attach the current scaling card to the MK101 connector on the service kit MDCIC. (See *chapter 15.1.3 Recommended Current Scaling Cards* for current scaling card part numbers.)
3. Connect the current scaling card to master drive slot (inverter1) on MDCIC.
4. Unplug the DC link connector (MK902) from the power card of the drive module.
5. Connect the 650 V DC connector from the split bus supply to the split bus connector (MK901) of the power card.
6. Connect the DC bus supply cable from the split bus supply (24 V DC) to the DC link connector (MK902).
7. Apply power to the split bus supply.
8. Check the display on the LCP. *Alarm 70, Illegal FC config* or *Warning 76, Power unit setup* appears.
9. Enter the appropriate type code for the module as listed in *Table 9.1*.
10. Save the setting to EEPROM.
11. Power cycle the drive module. The module is initialized in standalone mode, and is ready for testing as described in *chapter 8 Test Procedures*.

Module	Type code
N250T5	FC-302N250T5E00H2BGXXXX
N200T5	FC-302N200T5E00H2BGXXXX
N160T5	FC-302N160T5E00H2BGXXXX
N315T7	FC-302N315T7E00H2BGXXXX
N250T7	FC-302N250T7E00H2BGXXXX
N200T7	FC-302N200T7E00H2BGXXXX
N160T7	FC-302N160T7E00H2BGXXXX

Table 9.1 Type Code Selection Table

9.2.3 After-test Installation of Parallel Drive Modules

After completing tests of the parallel drive module in standalone mode, perform the following steps to return it to operation.

1. Remove power from the system.
2. Reinstall the module into the parallel drive system.
3. Reconnect DC and AC busbars to the module.
4. Connect the 44-pin ribbon cable MDCIC to the connectors at the top of the module.
5. Apply power to the drive. *Alarm 70, Illegal FC Config* appears.
6. Enter the parallel drive module type code (shown on the drive module label) and save it to EEPROM.
7. Power cycle the drive. The parallel drive module is ready for use.

9.2.4 Programming the Parallel Drive Module

1. Connect the 44-pin cable from the MDCIC of the service kit to the top plate of the parallel drive module.
2. Connect the current scaling card to master drive slot MK101 (Inv1) on the service kit MDCIC. See *chapter 15.1.3 Recommended Current Scaling Cards*.
3. Connect the 24 V option D card to the option D slot of the service kit.
4. Apply 24 V DC power supply to the option card. The parallel drive module is ready to be programmed.

9.2.5 Service Kit Troubleshooting

- If *alarm 240, Illegal PS config error* appears, verify that the correct current scaling card is placed in the parallel drive module.
- If *alarm 14, short circuit* appears, check that the current scaling card is placed correctly.
- If *alarm 243, Brake IGBT fault* appears, ensure that fuse microswitch harnesses are properly connected in the parallel drive module, even though the fuses are not used.
- Do not place the current scaling card in slots MK108–MK110.
- Ensure that both ends of the 44-pin MDCIC cable are properly seated in the connectors.

9.3 Signal Test Board

9.3.1 Signal Test Board

The signal test board (p/n 176F8437) provides access to various signals that can be helpful in troubleshooting the unit.

The signal test board is plugged into power card connector MK104. Points on the signal test board can be monitored with or without the DC bus disabled. Sometimes, the unit needs the DC bus enabled and operating a load to verify some test signals.

Table 9.2 is a description of the signals available on the signal test board. *Chapter 9 Special Test Equipment* of this guide explains when these tests are used and describes the correct test results.

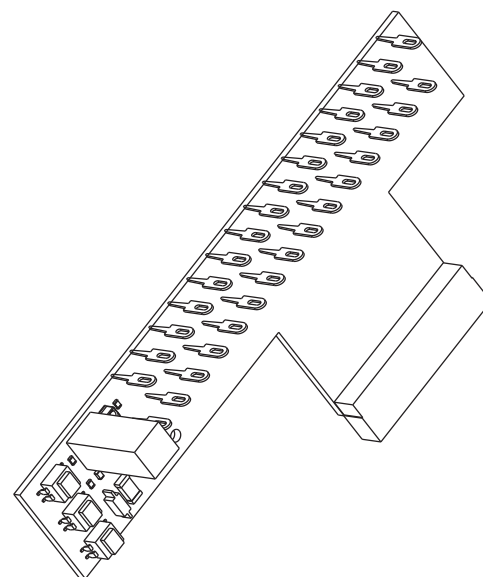

Illustration 9.6 Signal Test Board

130BX66.10

9.3.2 Signal Test Board Pin Outs

Table 9.2 lists the pins found on the signal test board. For each pin, its function, description, and voltage levels are provided. Details on performing tests using the test fixture are provided in *chapter 8 Test Procedures* of this guide. Other than power supply measurements, most of the signals being measured are made up of waveforms.

Sometimes, a digital voltmeter can be used to verify the presence of such signals. However, do not rely on the voltmeter to verify that the waveform is correct. An oscilloscope is the preferred instrument. When similar signals are being measured at multiple points, a digital voltmeter can be used with some accuracy. By comparing signals to one another, such as gate drive signals, and obtaining similar readings, it can be concluded that the waveforms match and are correct. Values are provided for using a digital voltmeter for testing as well.

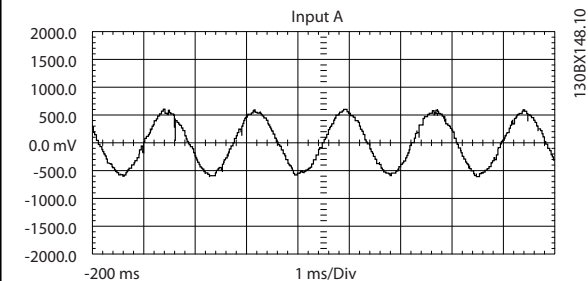
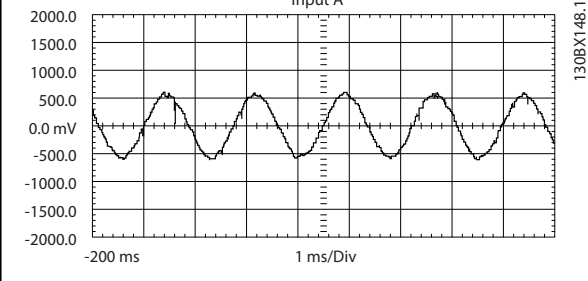
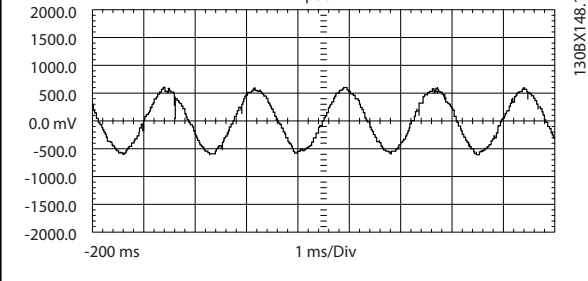
Pin No.	Schematic acronym	Function	Description	Reading using a digital voltmeter
1	IU1	Current sensed, U phase, not conditioned	 <p>Approximately 400 mV RMS at 100% load.</p>	0.937 V AC _{peak} at 165% of CT current rating. AC waveform at output frequency of the filter.
2	IV1	Current sensed, V phase, not conditioned	 <p>Approximately 400 mV RMS at 100% load.</p>	0.937 V AC _{peak} at 165% of CT current rating. AC waveform at output frequency of the filter.
3	IW1	Current sensed, W phase, not conditioned	 <p>Approximately 400 mV RMS at 100% load.</p>	0.937 V AC _{peak} at 165% of CT current rating. AC waveform at output frequency of the filter.
4	COMMON	Logic common	This common is for all signals.	
5		Not used		
6		Not used		
7	INRUSH	Control card signal	Signal from the control card to start gating the SCR front end. Signal not relevant in E1h–E4h drives.	3.3 V DC – Inrush mode 0 V DC – Run mode
8		Not used		
9		Not used		
10		Not used		

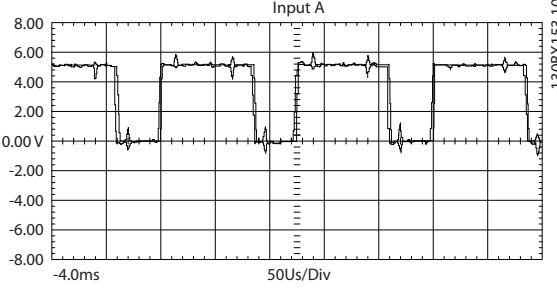
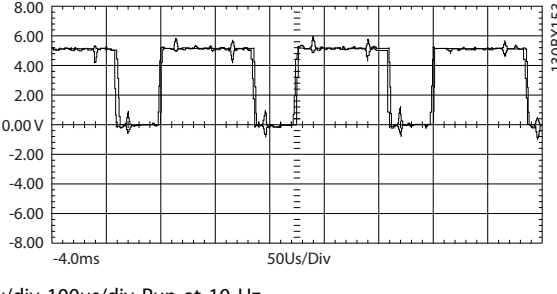
Pin No.	Schematic acronym	Function	Description	Reading using a digital voltmeter
11	VPOS	(+)18 V DC regulated supply (+)16.5 to 19.5 V DC	The red LED indicates that voltage is present between VPOS and VNEG terminals.	(+)18 V DC regulated supply (+)16.5–19.5 V DC
12	VNEG	(-)18 V DC regulated supply (-)16.5 to 19.5 V DC	The red LED indicates that voltage is present between VPOS and VNEG terminals.	(-)18 V DC regulated supply (-)16.5–19.5 V DC
13		Not used		
14		Not used		
15		Not used		
16		Not used		
17		Not used		
18		Not used		
19		Not used		
20	INV_DIS	Control signal from power card	Disables IGBT gate voltages.	5 V DC – inverter disabled 0 V DC – inverter enabled
21		Not used		
22	UINVEX	Bus voltage scaled down	Signal proportional to UDC.	0 V switch must be off (-)1 V DC=250 V DC
23	VDD	(+) 24 V DC power supply	Yellow LED indicates that voltage is present.	(+)24 V DC regulated supply (+)23–25 V DC
24	VCC	(+) 5.0 V DC regulated supply. (+) 4.75 to 5.25 VDC	The green LED indicates that voltage is present.	(+)5.0 V DC regulated supply (+)4.75–5.25 V DC
25	GUP_T	IGBT gate signal, buffered, U phase, positive. Signal originates on control card.	 <p>2v/div 100us/div Run at 10 Hz</p>	2.2–2.5 V DC Equal on all phases TP25–TP30
26	GUN_T	IGBT gate signal, buffered, U phase, negative. Signal originates on control card.	 <p>2v/div 100us/div Run at 10 Hz</p>	2.2–2.5 V DC Equal on all phases TP25–TP30

Pin No.	Schematic acronym	Function	Description	Reading using a digital voltmeter
27	GVP_T	IGBT gate signal, buffered, V phase, positive. Signal originates on control card.	 <p>2v/div 100us/div Run at 10 Hz</p>	2.2–2.5 V DC Equal on all phases TP25–TP30
28	GVN_T	IGBT gate signal, buffered, V phase, negative. Signal originates on control card.	 <p>2v/div 100us/div Run at 10 Hz</p>	2.2–2.5 V DC Equal on all phases TP25–TP30
29	GWP_T	IGBT gate signal, buffered, W phase, positive. Signal originates on control card.	 <p>2v/div 100us/div Run at 10 Hz</p>	2.2–2.5 V DC Equal on all phases TP25–TP30
30	GWN_T	IGBT gate signal, buffered, W phase, negative. Signal originates on control card.	 <p>2v/div 100us/div Run at 10 Hz</p>	2.2–2.5 V DC Equal on all phases TP25–TP30

Table 9.2 Signal Test Board Pins

10 D1h/D3h/D5h/D6h/J8 Drive Disassembly and Assembly

10.1 Before Proceeding

Review all safety warnings and cautions in *chapter 2 Safety*.

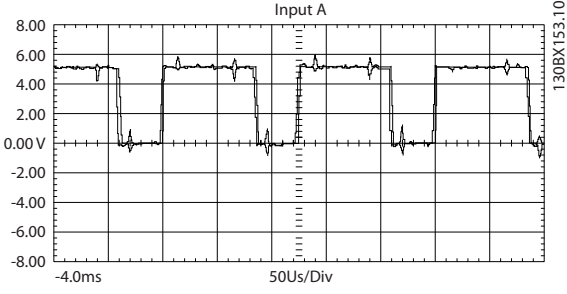
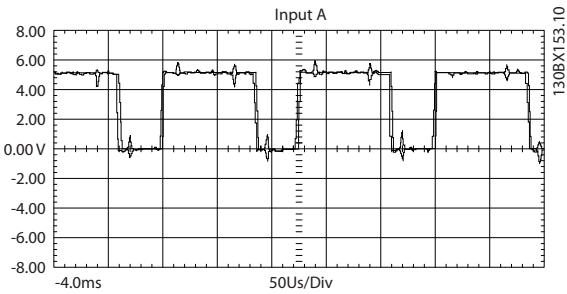
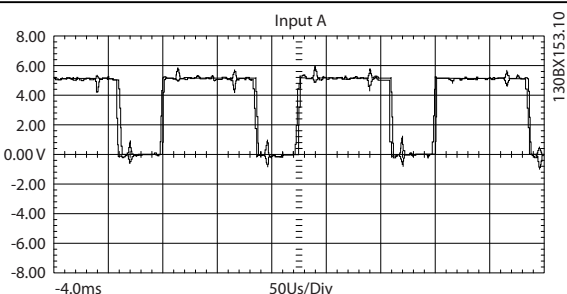
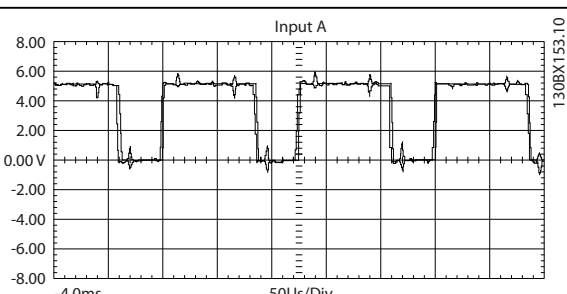
- DO NOT touch electrical parts of the drive when connected to mains. Also make sure that other voltage inputs have been disconnected (linkage of DC intermediate circuit). There can be high voltage on the DC-link even when the indicator lights are turned off. Before touching any potentially live parts of the drive, wait at least 40 minutes.
- Before conducting repair or inspection, disconnect mains.
- [Off] on the LCP does not disconnect mains.
- During operation and while programming parameters, the motor can start without warning. Press [Stop] when changing data.
- When operating on a PM motor, disconnect the motor cable.

⚠ WARNING DISCHARGE TIME

The drive contains DC-link capacitors, which can remain charged even when the drive is not powered. High voltage can be present even when the warning LED indicator lights are off. Failure to wait the specified time after power has been removed before performing service or repair work can result in death or serious injury.

- Stop the motor.
- Disconnect AC mains and remote DC-link power supplies, including battery back-ups, UPS, and DC-link connections to other drives.
- Disconnect or lock the motor.
- Disconnect any brake option.
- Disconnect any regen/load share option.
- Wait for the capacitors to discharge fully. The minimum waiting time is specified in the following discharge time table and is also visible on the drive label.
- Before performing any service or repair work, use an appropriate voltage measuring device to make sure that the capacitors are fully discharged. For parallel drive modules, measure DC-bus capacitor voltages before and after the individual DC fuses.

Enclosure Size	Minimum waiting time
D1h–D8h drives	20 minutes
J8–J9 drives	20 minutes
D9h–D10h enclosed drive systems	20 minutes
Da2/Da4/Db2/Db4 parallel drive systems	20 minutes
E1h–E4h drives	40 minutes
E5h–E6h enclosed drive systems	40 minutes

Table 10.1 Discharge Time

⚠ WARNING

SHOCK HAZARD

The following options are powered before the optional circuit breaker or disconnect. Even with the circuit breaker or disconnect in the OFF position, mains voltage is still present inside the drive enclosure.

Failure to turn off the main service line/power to the drive before working on the following options can result in death or serious injury:

- Door interlock
- Space heater
- Cabinet light and outlet
- RCD monitor
- IRM monitor
- Emergency stop
- 24 V DC customer supply

NOTICE

INTERLOCKED DOORS

If supplied with a circuit breaker or disconnect switch, the cabinet doors are interlocked. To open the cabinet doors, set the circuit breaker and disconnect switch to the OFF position.

NOTICE

ELECTROSTATIC DISCHARGE (ESD)

Many electronic components within the drive are sensitive to static electricity. Voltages so low that they cannot be felt, seen, or heard can be harmful to electronic components. Use standard ESD protective procedures whenever handling ESD sensitive components. Failure to conform to standard ESD procedures can reduce component life, diminish performance, or completely destroy sensitive electronic components.

NOTICE**ENCLOSURE SIZE**

Enclosure size designations are used throughout this guide where procedures or components differ between drives based on size. Refer to *chapter 3.4 Enclosure Size Identification* and *chapter 3.5 Enclosure Size Definitions* in determining enclosure size.

10.2 D1h/D3h/D5h/D6h/J8 Disassembly and Assembly

10.2.1 General Information

This chapter contains instructions for disassembly and assembly of D1h/D3h drives. The instructions can be used for related drives and drive modules listed in *Table 10.2*.

Model	Description
D1h drive	Standard drive in a IP21/IP54 enclosure
D3h drive	Standard drive in IP20/Chassis enclosure
D5h drive	Similar to D1h drive, with short extended options cabinet
D6h drive	Similar to D1h drive, with tall extended options cabinet
J8 drive (for FC 361)	Similar to D3h, without brake or regen/load share option. Available in Chinese market only.
Parallel drive modules	Similar to D3h, includes 2 or 4 drive modules in Da2/Da4 parallel drive system
Enclosed drive module	Similar to D3h, includes 1 drive module in D9h enclosed drive system

Table 10.2 Drives and Drive Modules Related to D1h Drive

10

10.2.2 Control Card and Control Card Mounting Plate

The control card and control terminals can remain attached when the control card mounting plate is removed from the drive. To remove or reinstall the control card mounting plate, use the following steps. Refer to *Illustration 10.1*.

Disassembly

1. Open the door or remove the front cover, depending on the enclosure type.
2. If present, remove the mains shield option by removing 6 screws (T25).
3. Remove the LCP and LCP cradle. The LCP and cradle can be removed by hand.
4. Remove any customer control wiring from the control card and option cards.
5. Remove 4 screws (T20) from the corners of the control card mounting plate.
6. Lift the plate and unplug the ribbon cable connecting the control card and the power card.
7. Remove the control card mounting plate from the drive.

Reassembly

Tighten fasteners according to *chapter 14.1 Fastener Torque Ratings*.

1. Connect the ribbon cable between the control card and the power card.
2. Position the control card mounting plate in the drive.
3. Secure 4 screws (T20), 1 in each corner of the control card mounting plate.
4. Replace any customer control wiring to the control card and option cards.
5. Replace the LCP and LCP cradle. The LCP and cradle can be replaced by hand.
6. Replace the door or front cover of the drive.

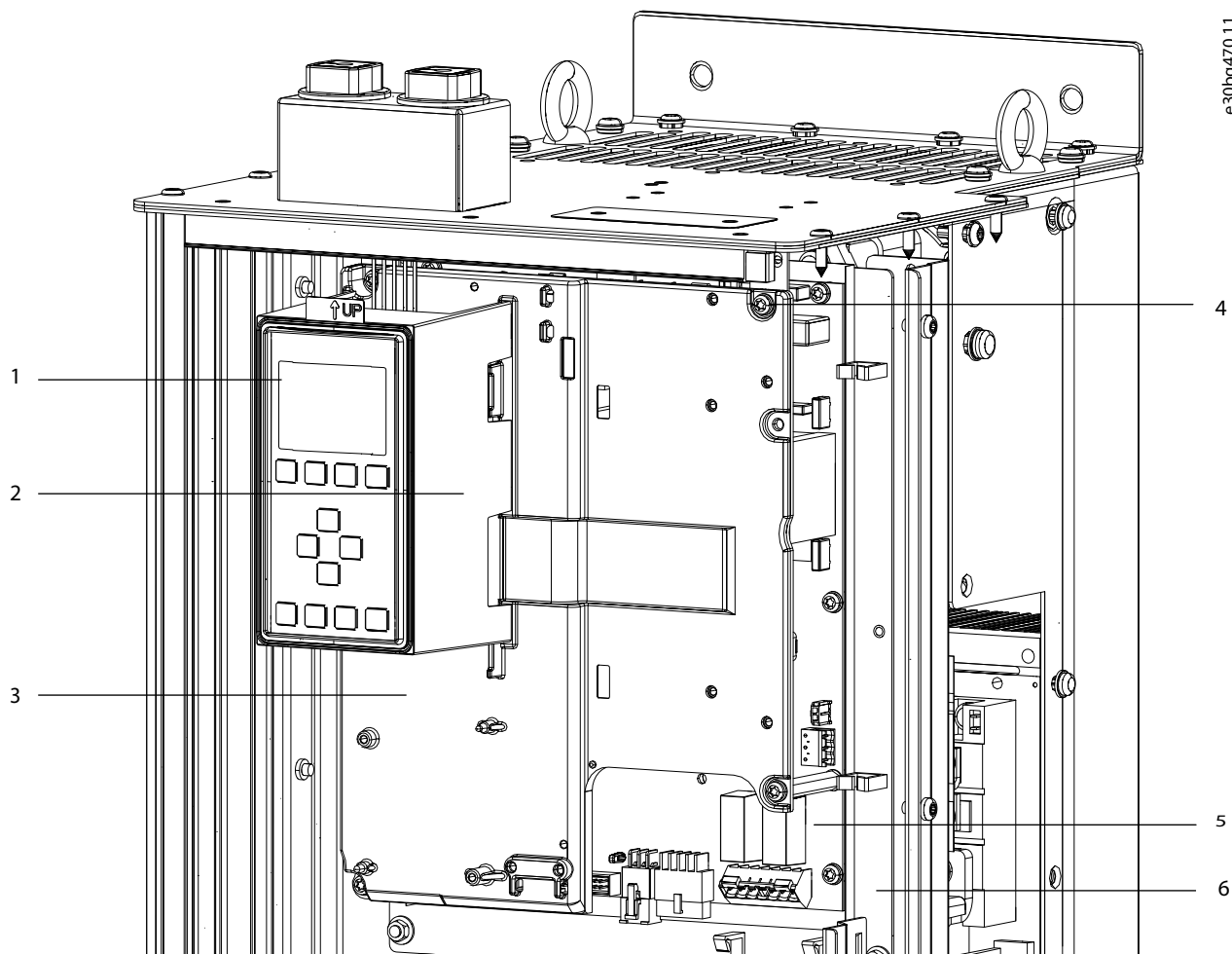

1	LCP (Local control panel)	4	Screw (T20)
2	LCP cradle	5	Power card
3	Control card mounting plate	6	Power card mounting plate

Illustration 10.1 Control Card Mounting Plate

10.2.3 Power Card Mounting Plate

The power card can remain attached when the power card mounting plate is removed from the drive. To remove the power card mounting plate with the card attached, use the following steps. Refer to *Illustration 10.2*.

To remove the power card from the plate, refer to *chapter 10.2.4 Power Card*.

The IP20 enclosure has a different type and number of fasteners.

Disassembly

1. Remove the control card mounting plate. Refer to *chapter 10.2.2 Control Card and Control Card Mounting Plate*.
2. Unplug the following power card connectors:
 - 2a MK101
 - 2b MK103
 - 2c MK501
 - 2d MK502
 - 2e MK902
 - 2f Any wiring at MK500 and MK 106
3. Remove 4 screws (T20), 1 from each corner of the mounting plate.
4. Remove 1 screw (T25) from the top center of the mounting plate.
5. Free the cables from the retaining clips on the plate.
6. Lift the power card mounting plate from the drive.

Reassembly

Tighten hardware according to *chapter 14.1 Fastener Torque Ratings*.

1. Position the power card mounting plate in the drive.
2. Secure 1 screw (T25) in the top center of the mounting plate.
3. Secure 4 screws (T20), 1 in each corner of the mounting plate.
4. Attach the following power card connectors:
 - 4a MK101
 - 4b MK103
 - 4c MK501
 - 4d MK502
 - 4e MK902
 - 4f Any wiring at MK500 and MK106
5. Route the cables through the retaining clips.
6. Replace the control card mounting plate. Refer to *chapter 10.2.2 Control Card and Control Card Mounting Plate*.

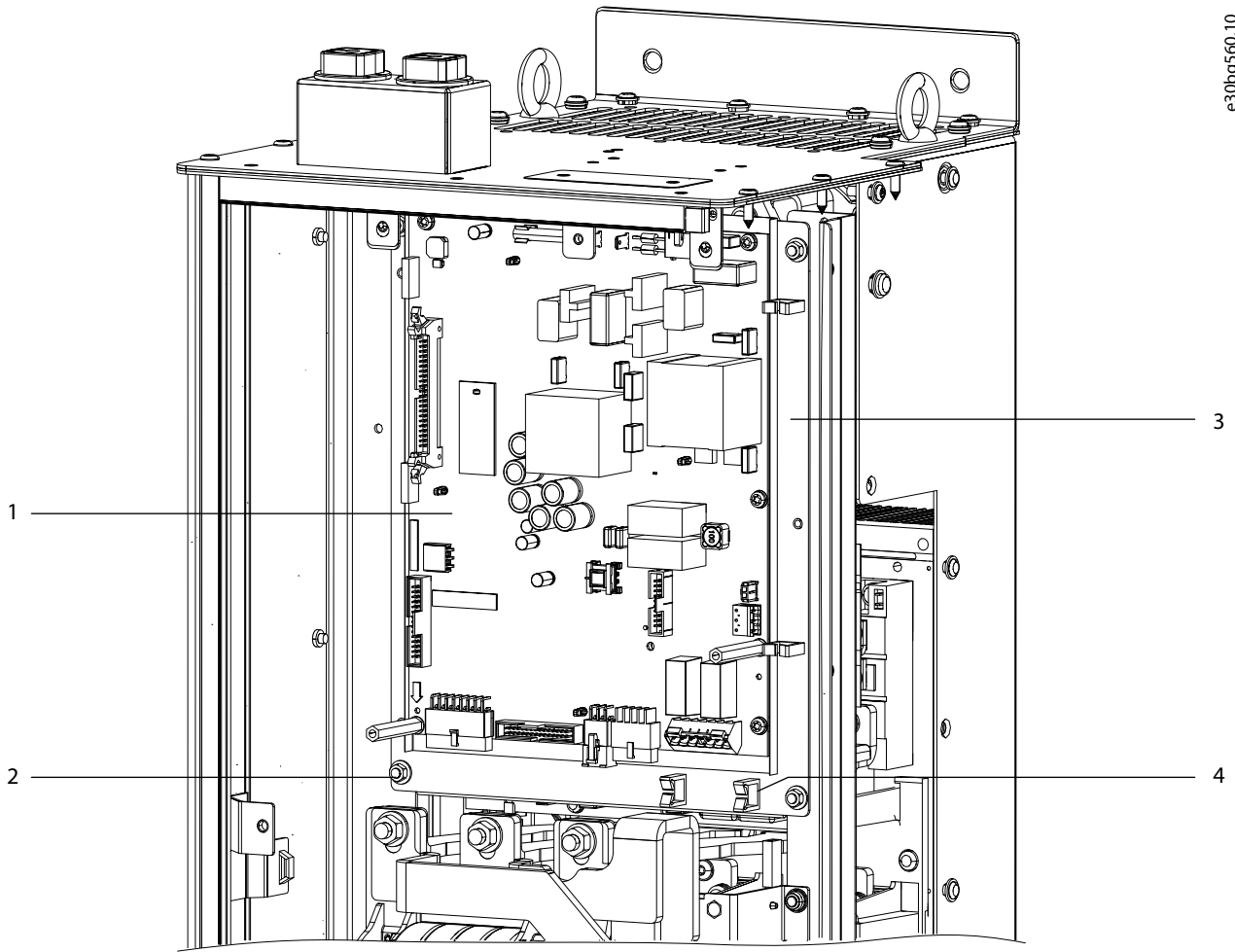

1	Power card (PCA3)	3	Power card mounting plate
2	Screw (T20)	4	Cable retaining clip

Illustration 10.2 Power Card Mounting Plate

10.2.4 Power Card

To remove or reinstall the power card, use the following steps. Refer to *Illustration 10.3*.

NOTICE

PARTS CONFIGURATION

In D1h–D8h and J8 units, the current scaling card is on the power card. In parallel drive systems, the current scaling card is on the MDCIC.

Disassembly

1. Remove the control card mounting plate. Refer to *chapter 10.2.2 Control Card and Control Card Mounting Plate*.
2. Unplug the power card connectors:
 - 2a MK101
 - 2b MK103
 - 2c MK501
 - 2d MK502
 - 2e MK902
 - 2f Any additional, customer-supplied wiring at MK106 and MK500
3. Remove 5 screws (T20).
4. Remove 2 standoffs (8 mm).
5. Remove the power card from 3 plastic standoffs.
6. Remove the current scaling card from the power card by pinching together the tip of the plastic standoff.

NOTICE

PARTS REUSE

Replacement power cards do not include a current scaling card. Keep the current scaling card for future installation with any replacement power card.

Reassembly

Tighten hardware according to *chapter 14.1 Fastener Torque Ratings*.

1. Install the current scaling card at MK100 on the power card.
2. Position the insulator sheet on the power card mounting plate.
3. Press the power card onto 3 plastic standoffs.
4. Secure 2 standoffs (8 mm).
5. Secure 5 screws (T20) in the power card.
6. Attach cables to the power card connectors:
 - 6a MK101
 - 6b MK103
 - 6c MK501
 - 6d MK502
 - 6e MK902
 - 6f Any additional, customer-supplied wiring at MK106 and MK500
7. Replace the control card mounting plate. Refer to *chapter 10.2.2 Control Card and Control Card Mounting Plate*.

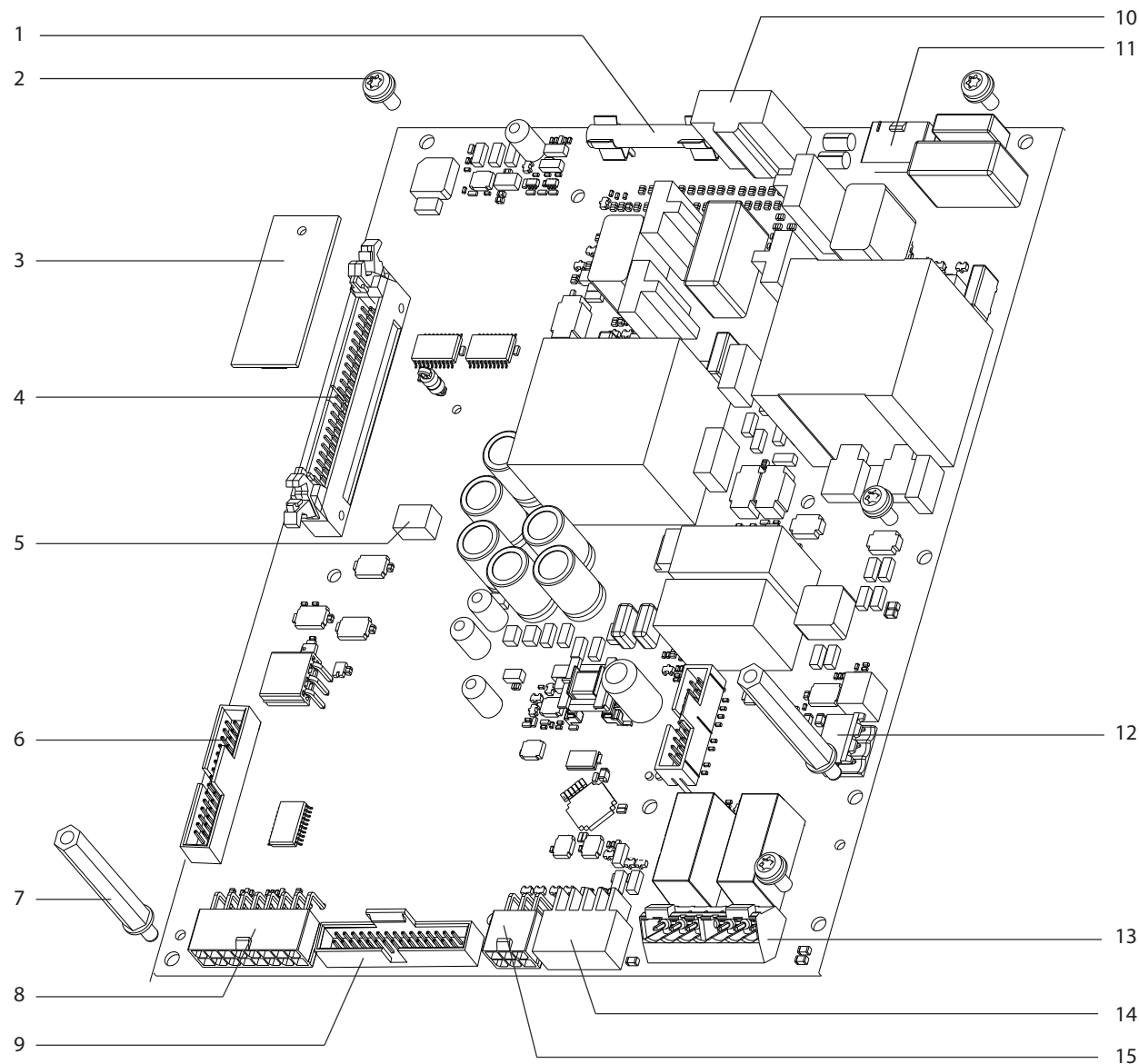

10

1	FK901: SMPS fuse	9	MK103: Gate drive and inrush control signals
2	Screw (T20)	10	MK901: DC input terminals (used with split bus power supply)
3	Current scaling card (not in parallel drive modules)	11	MK902: DC voltage from DC bus to power card SMPS
4	MK102: Control card to power card connection	12	MK106: Brake temperature switch input
5	MK100: Current scaling card connector (not in parallel drive modules)	13	MK500: Customer terminals for relays 1 and 2
6	MK104: Signal test board connector	14	MK501: Heat sink and door/top fan control
7	Standoff (8 mm)	15	MK502: EMC relay control
8	MK101: Current sensor feedback	-	-

Illustration 10.3 Power Card

10.2.5 AC Input Busbars

To remove the AC input busbars, use the following steps. The AC input busbars can look different when the drive includes extra input options, such as RFI filter or fuses.

Illustration 10.4 shows the AC input busbars with both RFI filter and AC fuses, and *Illustration 10.5* shows the AC input busbars with no options.

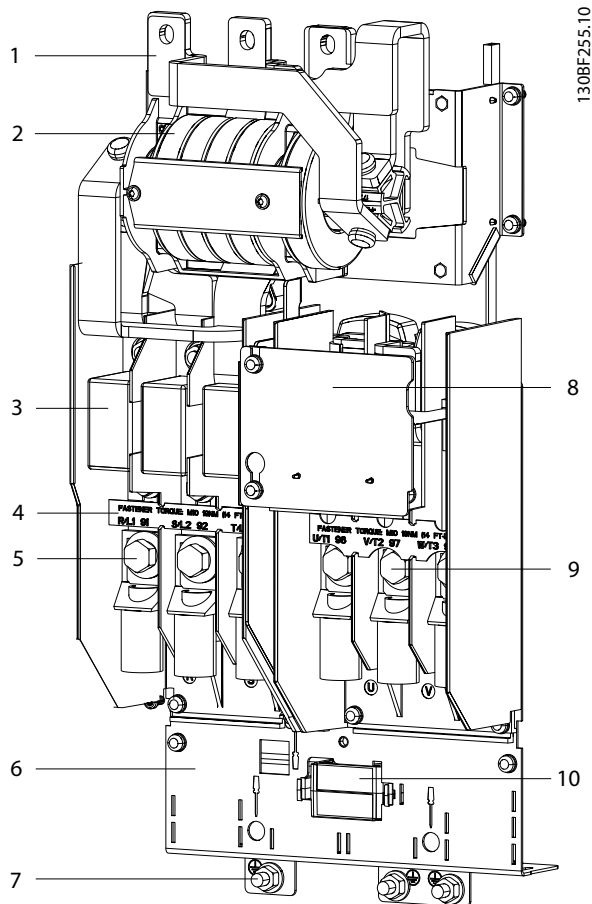

1	AC input busbar	6	Power terminal mounting plate
2	RFI filter (optional)	7	Nut
3	AC fuse (optional)	8	EMC shield
4	R/S/T terminal label	9	Motor terminal
5	Mains input terminal	10	Mixing fan

Illustration 10.4 AC Input Busbars with RFI Filter and Fuses

1. Remove the air baffle by removing 4 screws (T25) and 2 nuts (13 mm).
2. The next step differs based on the input options present in the drive. Select the appropriate procedure for the drive:

- 2a No options.
- 2b AC fuses only.
- 2c RFI filter only.
- 2d AC fuses and RFI filter.

10.2.5.1 No Options

1. Remove 3 nuts (10 mm) at the top of the AC input busbars, 1 per phase.
2. Remove 6 nuts (13 mm) at the bottom of the AC input busbars, 2 per phase.
3. Remove the busbars from the drive.

Reinstall in reverse order of this procedure. Tighten hardware according to *chapter 14.1 Fastener Torque Ratings*.

10.2.5.2 AC Fuses Only

1. Remove AC fuses by removing 6 nuts (13 mm), 1 at each end of 3 fuses.
2. Remove 3 nuts (10 mm) at the top of the AC input busbars, 1 per phase.
3. Remove the AC input busbars.

Reinstall in reverse order of this procedure. Tighten hardware according to *chapter 14.1 Fastener Torque Ratings*.

10.2.5.3 RFI Filter Only

1. Remove 3 nuts (10 mm) at the top of the RFI filter, 1 per bus phase.
2. Remove 6 nuts (13 mm) at the bottom of the RFI filter, 2 per phase.
3. Remove 4 screws (T20) connecting the RFI filter to the side channels of the drive.
4. Remove the RFI filter and unplug the RFI cable from MK100 on the printed circuit card assembly.

Reinstall in reverse order of this procedure. Tighten hardware according to *chapter 14.1 Fastener Torque Ratings*.

10.2.5.4 AC Fuses and RFI Filter

1. Remove AC fuses by removing 6 nuts (13 mm), 1 at each end of 3 fuses.
2. Remove 3 nuts (10 mm) from the top of the RFI filter, 1 per phase.
3. Remove 4 screws (T20) connecting the RFI filter to the side channels of the drive.
4. Remove the RFI filter and unplug the RFI cable from MK100 on the printed circuit card assembly.

Reinstall in reverse order of this procedure. Tighten hardware according to *chapter 14.1 Fastener Torque Ratings*.

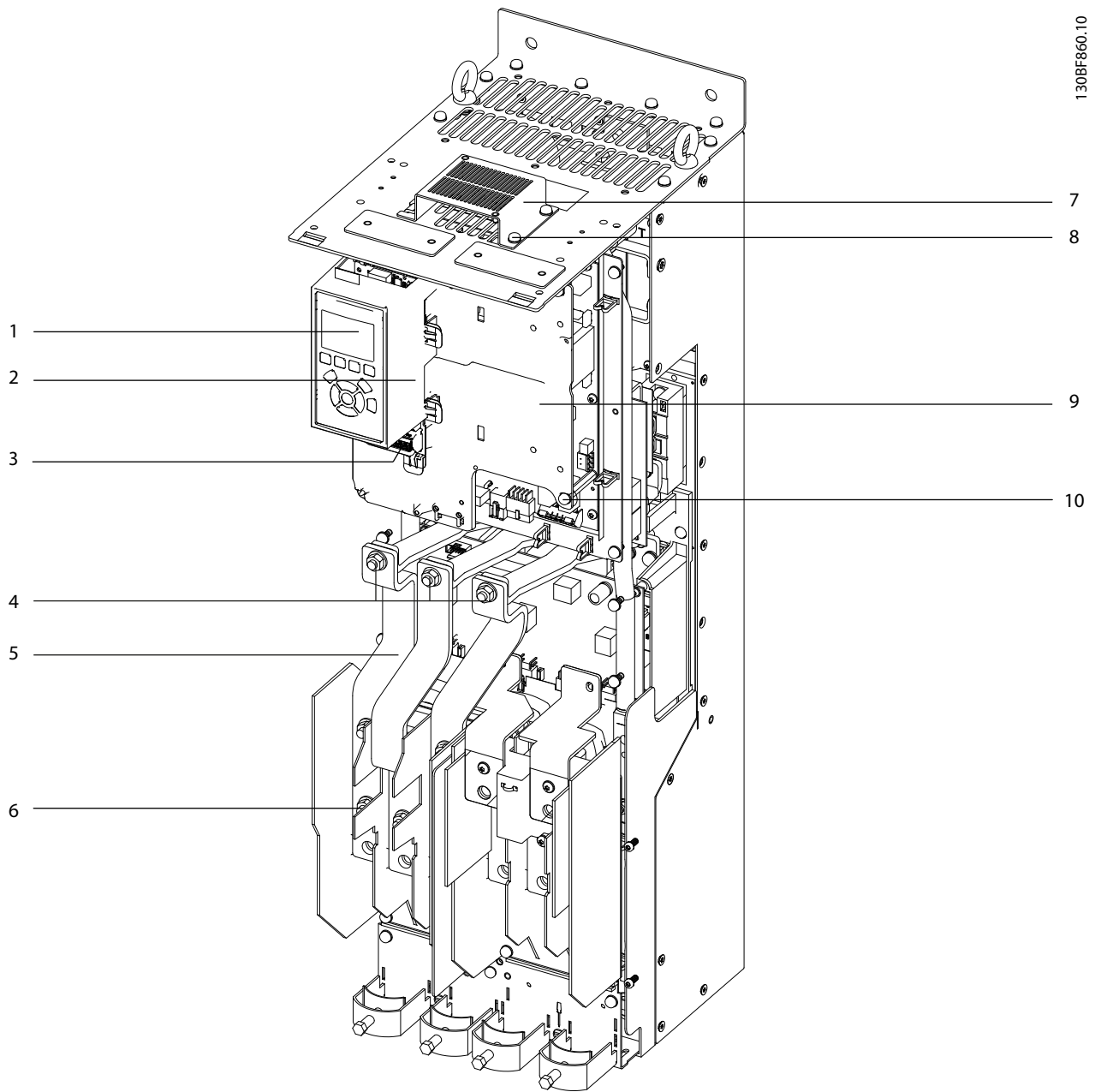

10

1	LCP (local control panel)	6	Nut (13 mm)
2	LCP cradle	7	Top fan (IP20)
3	Control terminals	8	Screw (T25)
4	Nut (10 mm)	9	Control card mounting plate
5	AC input busbars	10	Screw (T20)

Illustration 10.5 AC Input Busbars and Power Terminals

10.2.6 Mains Input Terminal Block

To remove or reinstall the mains input terminal block, use the following steps. Refer to *Illustration 10.6*.

Disassembly

1. Disconnect any customer input power wiring, and remove the R/S/T terminal label.
2. Remove the AC input busbars. Refer to *chapter 10.2.5 AC Input Busbars*.
3. Remove 2 screws (T25) at the bottom of the terminal block.
4. Remove the terminal by sliding it down to disengage it from the 2 metal retaining clips on the mounting plate. It can be necessary to remove 1 screw (T25) from the EMC shield when removing the terminal block.

Reassembly

Tighten hardware according to *chapter 14.1 Fastener Torque Ratings*.

1. Place the terminal in its original position by sliding it under the 2 metal retaining clips.
2. Secure 2 screws (T25) at the bottom of the terminal block.
3. Replace the AC input busbars. Refer to *chapter 10.2.5 AC Input Busbars*.
4. Reconnect any customer input power wiring, and replace the R/S/T terminal label.

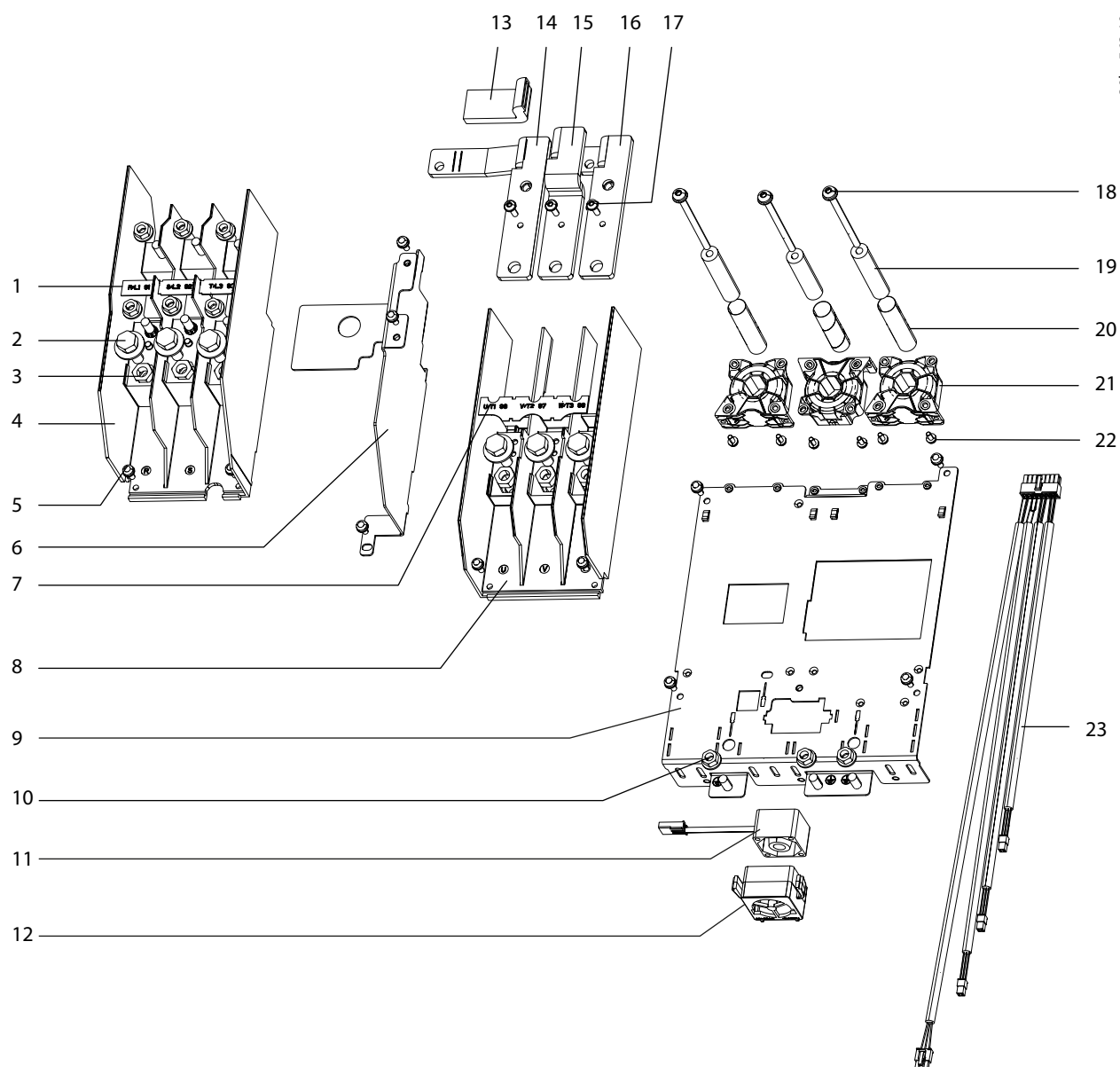

10

1	R/S/T terminal label	13	Insulator sleeve
2	Screw	14	U busbar
3	Nut	15	V busbar
4	Mains input terminal block	16	W busbar
5	Screw	17	Screw
6	EMC shield	18	Screw
7	U/V/W terminal label	19	Cylinder busbar
8	Motor terminal block	20	Nomex tube
9	Power terminal mounting plate	21	Current sensor
10	Nut	22	Thread-forming screw
11	Mixing fan	23	Wire harness (current sensor cables)
12	Mixing fan housing	-	-

Illustration 10.6 Power Terminals

10.2.7 Motor Terminal Block

To remove or reinstall the motor terminal block, use the following steps. Refer to *Illustration 10.6*.

Disassembly

1. Remove the mains input terminal block. Refer to *chapter 10.2.6 Mains Input Terminal Block*.
2. Remove the optional brake terminal, if present. Refer to *chapter 10.2.8 Brake Terminal Block (Optional)*.
3. Disconnect wiring to the motor, and remove the U/V/W terminal label.
4. Remove the EMC shield between the mains input and motor terminal blocks by removing 2 screws (T25).
5. To remove the U motor busbar:
 - 5a Remove 1 thread-forming screw (T25) from the middle of the U busbar.
 - 5b Unfasten 1 screw (T30) from the current sensor end of the busbar.
6. To remove the V motor busbar:
 - 6a Remove 1 thread-forming screw (T25) from the middle of the V busbar.
 - 6b Unfasten 1 screw (T30) from the current sensor end of the busbar. Note that the V screw is shorter than the U and W screws.
7. To remove the W motor busbar:
 - 7a Remove 1 thread-forming screw (T25) from the middle of the W busbar.
 - 7b Unfasten 1 screw (T30) at the current sensor end of the busbar.
8. Remove 2 screws (T25) at the bottom of the motor terminal block.
9. Remove the motor terminal block by sliding it down to release it from the 2 metal retaining clips.
10. Remove the 3 cylinder busbars, 1 from the center of each current sensor.

Reassembly

Tighten hardware according to *chapter 14.1 Fastener Torque Ratings*.

1. Position the motor terminal block by sliding it upward under the 2 metal retaining clips.
2. Fasten 2 screws (T25) at the lower end of the motor terminal block.
3. Place 3 Nomex tubes in the drive, 1 in the center of each current sensor. Place the shorter tube (marked with a red line) through the middle current sensor.
4. Place 3 cylinder busbars in the drive, 1 inside each Nomex tube. Place the shorter busbar through the middle Nomex tube.
5. To replace the U motor busbar:
 - 5a Slide the insulator sleeve over the U busbar (if not already in place).
 - 5b Fasten 1 screw (T30) in the current sensor end of the busbar.
 - 5c Fasten 1 thread-forming screw (T25) in the middle of the busbar.
6. To replace the V motor busbar:
 - 6a Fasten 1 screw (T30) in the current sensor end of the busbar. The V bolt is shorter than the U/W bolts.
 - 6b Fasten 1 thread-forming screw (T25) in the middle of the busbar.
7. To replace the W motor busbar:
 - 7a Fasten 1 screw (T30) in the current sensor end of the busbar.
 - 7b Fasten 1 thread-forming screw (T25) in the middle of the busbar.
8. Position the EMC shield between the mains input terminal block and motor terminal block and secure with 2 screws (T25).
9. Reconnect wiring to motor terminals, and replace the U/V/W terminal label.

10.2.8 Brake Terminal Block (Optional)

Drives can include an optional brake. To remove or reinstall the optional brake terminal block, use the following steps.

Disassembly

1. Disconnect the brake wiring.
2. To remove the R(+) terminal:
 - 2a Remove 1 thread-forming screw (T25).
 - 2b Remove 1 screw (T40).
3. To remove the R(-) terminal:
 - 3a Remove 1 thread-forming screw (T25).
 - 3b Remove 1 nut (13 mm).
4. To remove the brake terminal block:
 - 4a Remove 2 nuts (13 mm).
 - 4b Lift the terminal block from the drive.

Reassembly

Reinstall the brake terminal block using the following steps. Tighten fasteners according to *chapter 14.1 Fastener Torque Ratings*.

1. Position the optional brake terminal block in the drive.
2. Secure 2 nuts (T40) in the brake terminal block.
3. Fasten the R (-) terminal using 1 thread-forming screw (T20) at the terminal block, and 1 nut (T40).
4. Fasten the R (+) terminal using 1 thread-forming screw (T20) at the terminal block, and 1 screw (T40).
5. Reconnect the brake wiring.

10.2.9 Power Terminal Mounting Plate

To remove or reinstall the power terminal mounting plate, use the following steps. Refer to *Illustration 10.6* and *Illustration 10.8*.

Disassembly

1. Remove the motor terminal block. Refer to *chapter 10.2.7 Motor Terminal Block*.
2. Remove the mixing fan. See *chapter 10.2.10 Mixing Fan*.
3. Remove 4 thread-cutting screws (T20), 2 from each side of the power terminal mounting plate.
4. For IP21/IP54 (UL type 1/12) enclosures only, remove 3 screws (T25) from the bottom of the drive.

Reassembly

Tighten hardware according to *chapter 14.1 Fastener Torque Ratings*.

1. Position the power terminal mounting plate in the drive.
2. Replace the mixing fan. See *chapter 10.2.10 Mixing Fan*.
3. For IP21/IP54 (UL type 1/12) enclosures only, fasten 3 screws (T25) from the bottom of the drive.
4. Fasten 4 thread-cutting screws (T20), 2 in each side of the power terminal mounting plate.
5. Replace the motor terminal block. Refer to *chapter 10.2.7 Motor Terminal Block*.

10.2.10 Mixing Fan

The mixing fan snaps into a slot in the power terminal mounting plate. To remove or reinstall the mixing fan, use the following steps. See *Illustration 10.7*.

Disassembly

1. Place the end of a screwdriver under each of the mixing fan release tabs. Press in and lift to free the fan and housing from the power terminal mounting plate.
2. Unplug the mixing fan cable connector. Tape the free end of the fan cable to the mounting plate so that it does not fall back into the drive.
3. Remove the mixing fan from the fan housing.

Reassembly

1. Connect the fan cable to the mixing fan cable connector.
2. Position the mixing fan in the fan housing.
3. Position the fan and housing in the fan slot on the power terminal mounting plate.
4. Press the mixing fan into the slot until the release tabs snap into place.

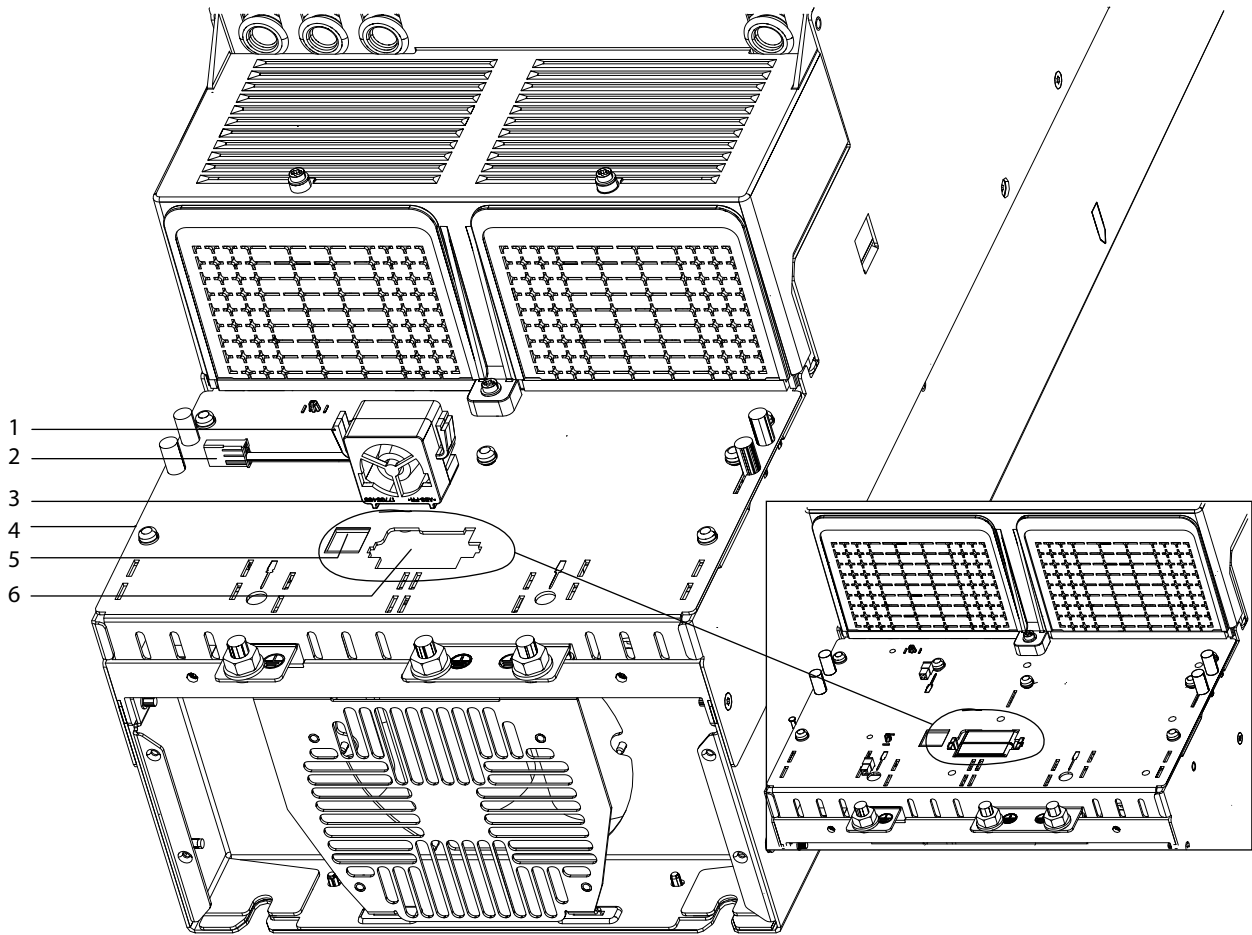

e30bg294.10

10

1	Mixing fan release tab	4	Power terminal mounting plate
2	Cable connector	5	Cable access hole
3	Mixing fan	6	Mixing fan slot

Illustration 10.7 Mixing Fan

10.2.11 Current Sensors

To remove or reinstall the current sensors, use the following steps. Refer to *Illustration 10.8*.

NOTICE

PARTS TYPE

Some current sensors look different than the sensors shown in this guide. LEM is the manufacturer of current sensors used in production since the first quarter of 2016. Previously, Honeywell manufactured the current sensors.

Disassembly

1. Remove the power terminal mounting plate. Refer to *chapter 10.2.9 Power Terminal Mounting Plate*.
2. Disconnect the wire harness from the wire connector on each of the 3 current sensors.
3. Remove 6 screws (T20), 2 from each of the 3 current sensors.
4. Remove the current sensors from the drive.

Reassembly

Tighten fasteners according to *chapter 14.1 Fastener Torque Ratings*, unless otherwise noted.

1. Position the outer 2 current sensors at the top of the power terminal mounting plate with the current sensor base against the plate.
2. Invert the middle current sensor so that the wider base is at the top.
3. Align the current sensors so that the cable connectors face the back of the unit, and the arrows on the sensors point outward.
4. Attach the 3 current sensors to the power terminal mounting plate by fastening 6 thread-forming screws (T20), 2 per sensor. Torque screws to 2.0 Nm (17.7 in-lb).
5. Connect the current sensor cables to the 3 cable connectors on the current sensors, 1 per current sensor.
6. Attach the 16-pin connector to MK101 on the power card, and route the current sensor cables through the cable guides on the power terminal mounting plate.
7. Replace the power terminal mounting plate. Refer to *chapter 10.2.9 Power Terminal Mounting Plate*.

e30bg562.10

10

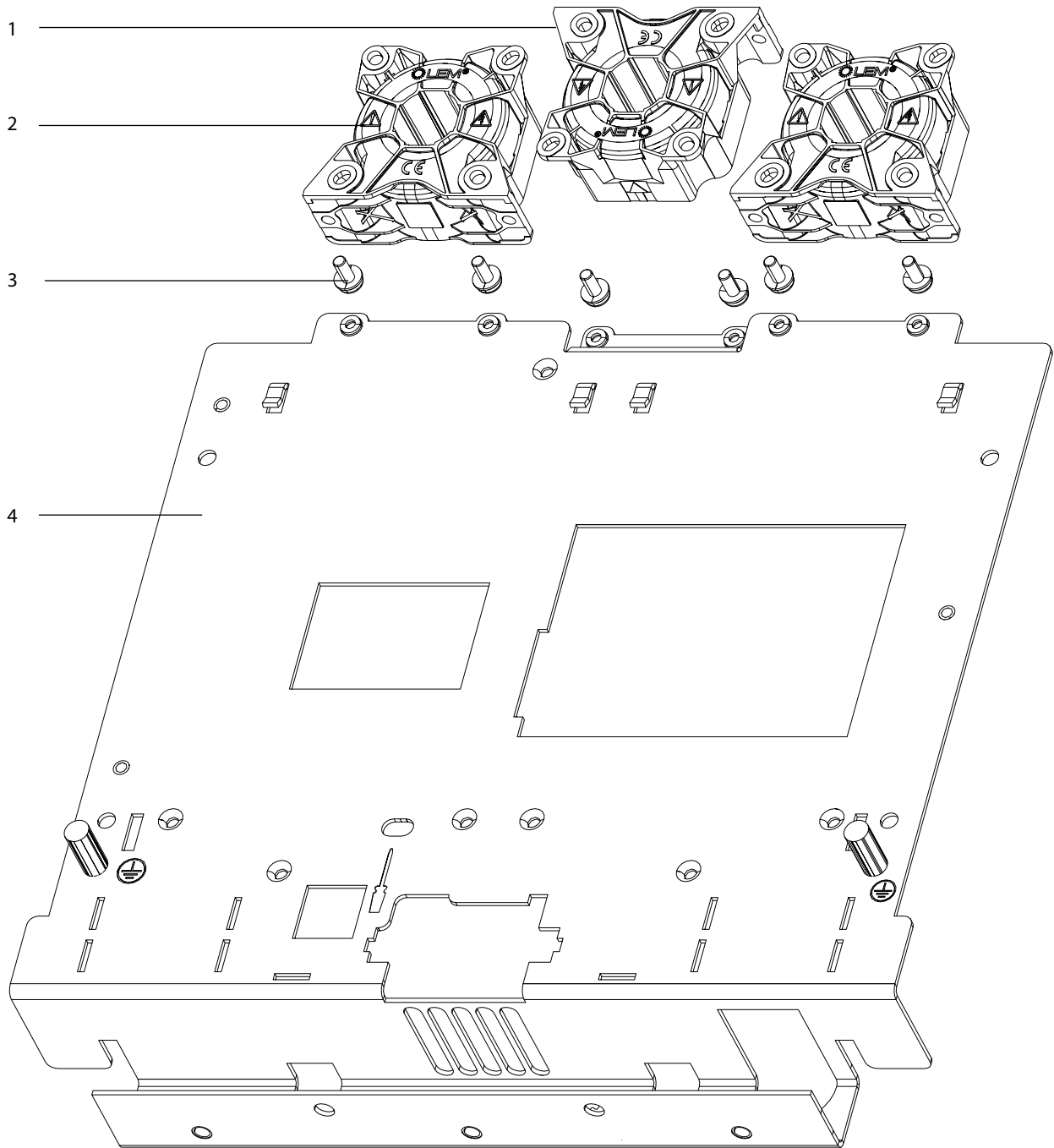

1	Middle current sensor (inverted position)	3	Thread-forming screw (T20)
2	Outer current sensor (upright position)	4	Power terminal mounting plate (IP20/Chassis)

Illustration 10.8 Current Sensors in D3h Drive

10.2.12 Balance/High Frequency Card

To remove or reinstall the balance/high frequency card, use the following steps. See *Illustration 10.13* and *Illustration 10.14*.

Disassembly in 240/400 V AC units

1. Remove the power terminal mounting plate. Refer to *chapter 10.2.9 Power Terminal Mounting Plate*.
2. Unplug the cable from the MK100 connector on the balance/high frequency card.
3. Remove 1 standoff (8 mm) from the corner of the card.
4. Remove 2 nuts (8 mm) and 1 screw (T25) from the card. Two of the fasteners also hold in place the DC(+) and DC(-) wires.
5. Remove the balance/high frequency card and insulator sheet from the drive.

Reassembly in 240/400 V AC units

Tighten hardware according to *chapter 14.1 Fastener Torque Ratings*.

1. Position the insulator sheet and balance/high frequency card in the drive.
2. Fasten 2 nuts (8 mm) and 1 screw (T25) in the card. Two of the nuts also hold in place the DC(+) and DC(-) wires.
3. Secure 1 standoff (8 mm) in the corner of the card.
4. Attach the cable to the MK100 connector on the balance/high frequency card.
5. Replace the power terminal mounting plate. Refer to *chapter 10.2.9 Power Terminal Mounting Plate*.

Disassembly in 690 V AC units

1. Remove the power terminal mounting plate. Refer to *chapter 11.2.11 Power Terminal Mounting Plate*.
2. Unplug the cable from the MK100 connector on the balance/high frequency card.
3. Remove 1 standoff (8 mm) from the corner of the card.
4. Remove 3 nuts (8 mm) and 1 screw (T20) from the card. One of the nuts and the screw also hold in place the DC(+) and DC(-) wires.
5. Remove the balance/high frequency card and insulator sheet from the drive.

Reassembly in 690 V AC units

Tighten hardware according to *chapter 14.1 Fastener Torque Ratings*.

1. Position the insulator sheet and balance/high frequency card in the drive.
2. Fasten 3 nuts (8 mm) and 1 screw (T20) in the card. One of the nuts and the screw also hold in place the DC(+) and DC(-) wires.
3. Secure 1 standoff (8 mm) in the corner of the card.
4. Attach the cable to the MK100 connector on the balance/high frequency card.
5. Replace the power terminal mounting plate. Refer to *chapter 11.2.11 Power Terminal Mounting Plate*.

10.2.13 DC Bus Rails

To remove or reinstall the DC bus rails, use the following steps. Refer to *Illustration 10.9*.

Disassembly

1. Remove the power card mounting plate. Refer to *chapter 10.2.3 Power Card Mounting Plate*.
2. Remove the power terminal mounting plate. Refer to *chapter 10.2.9 Power Terminal Mounting Plate*.
3. If there is a brake option, to remove the 2 brake-to-DC link busbars:
 - 3a Remove 2 screws (T30), 1 per busbar.
 - 3b Remove 2 nuts (10 mm), 1 per busbar.
4. Remove 2 screws (T30) at the top end of the DC bus rails, 1 per bus rail.
5. Remove 2 nuts (10 mm) from the lower end of the DC bus rails, 1 per bus rail.
6. Lift the DC bus rails from the drive.

Reassembly

Tighten hardware according to *chapter 14.1 Fastener Torque Ratings*.

1. Position the DC bus rails in the drive.
2. Secure 2 nuts (10 mm) at the lower end of the DC bus rails, 1 per bus rail.
3. Fasten 2 screws (T30) at the top end of the DC bus rails, 1 per bus rail.
4. If there is a brake option, to replace the 2 brake-to-DC link busbars:
 - 4a Fasten 2 screws (T30), 1 per busbar.
 - 4b Fasten 2 nuts (10 mm), 1 per busbar.
5. Replace the power terminal mounting plate. Refer to *chapter 10.2.9 Power Terminal Mounting Plate*.
6. Replace the power card mounting plate. Refer to *chapter 10.2.3 Power Card Mounting Plate*.

10.2.14 Inrush Card

To remove or reinstall the inrush card, use the following steps. Refer to *Illustration 10.9*.

Disassembly

1. Remove the DC bus rails. Refer to *chapter 10.2.13 DC Bus Rails*.
2. Unplug the cables from the following connectors on the inrush card:
 - 2a MK1800
 - 2b MK1802
3. Remove 5 screws (T20) from the inrush card.
4. Remove the inrush card from the drive.

Reassembly

Tighten hardware according to *chapter 14.1 Fastener Torque Ratings*.

1. Position the inrush card in the drive.
2. Fasten 5 screws (T20) in the inrush card.
3. Fasten the cables to the following connectors on the inrush card:
 - 3a MK1800
 - 3b MK1802
4. Replace the DC bus rails. Refer to *chapter 10.2.13 DC Bus Rails*.

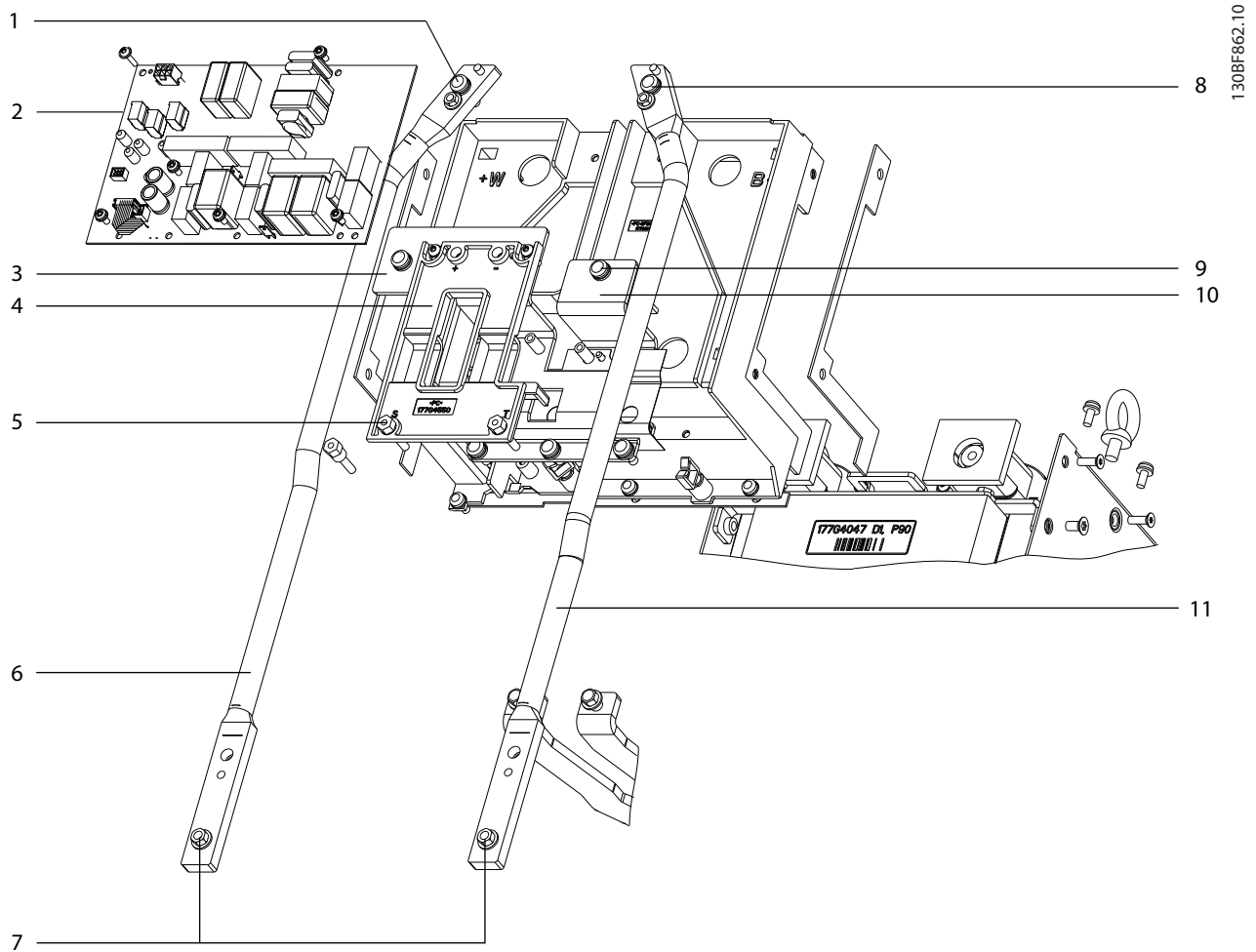

10

1	Screw (T30)	7	Nut (10 mm)
2	Inrush card	8	Screw (T30)
3	DC(+) busbar	9	Screw (T30)
4	Inrush support bracket	10	DC(-) busbar
5	Threaded standoff (11 mm)	11	DC(-) busbar (DC coil to capacitor bank)
6	DC(-) busbar (DC coil to capacitor bank)	-	-

Illustration 10.9 DC Bus Rails and Inrush Card

10.2.15 SCR Input Busbars

To remove or reinstall the SCR busbars, use the following steps. Refer to *Illustration 10.10*.

Disassembly

1. Remove the inrush card. Refer to *chapter 10.2.14 Inrush Card*.
2. Remove 3 standoffs (11 mm), 1 from each SCR input busbar.
3. Remove 2 screws (T25) from the black plastic inrush support.
4. Remove 3 screws (T30) connecting the busbars to the SCR modules, 1 from each busbar.
5. Remove the SCR input busbars.

NOTICE

COMPONENT ALIGNMENT

Fasten all components hand-tight, and then place the inrush support enclosure to align components before tightening.

Reassembly

Tighten hardware according to *chapter 14.1 Fastener Torque Ratings*.

1. Position the SCR input busbars in the drive.
2. Fasten 3 screws (T30) connecting the busbars to the SCR modules, 1 in each busbar.
3. Fasten 2 screws (T25) in the black plastic inrush support.
4. Secure 3 standoffs (11 mm), 1 in each SCR input busbar.
5. Replace the inrush card. Refer to *chapter 10.2.14 Inrush Card*.

10.2.16 SCRs

To remove or reinstall the SCR modules, use the following steps. Refer to *Illustration 10.10*.

Disassembly

1. Remove the SCR input busbars. Refer to *chapter 10.2.15 SCR Input Busbars*.
2. Remove the DC(+) busbar SCR to DC coil by first removing 1 screw (T30) that attaches the busbar to the DC inductor.
3. Remove 1 screw (T30) from each SCR module.
4. Remove the insulator sheet.
5. Remove the DC(-) busbar SCR to DC coil by first removing 1 screw (T30).
6. Disconnect the gate leads, 1 from each SCR module.
7. Remove 2 screws (T30) from each SCR module.

Reassembly

For reassembly, refer to the SCR replacement instructions that come with the spare parts kit.

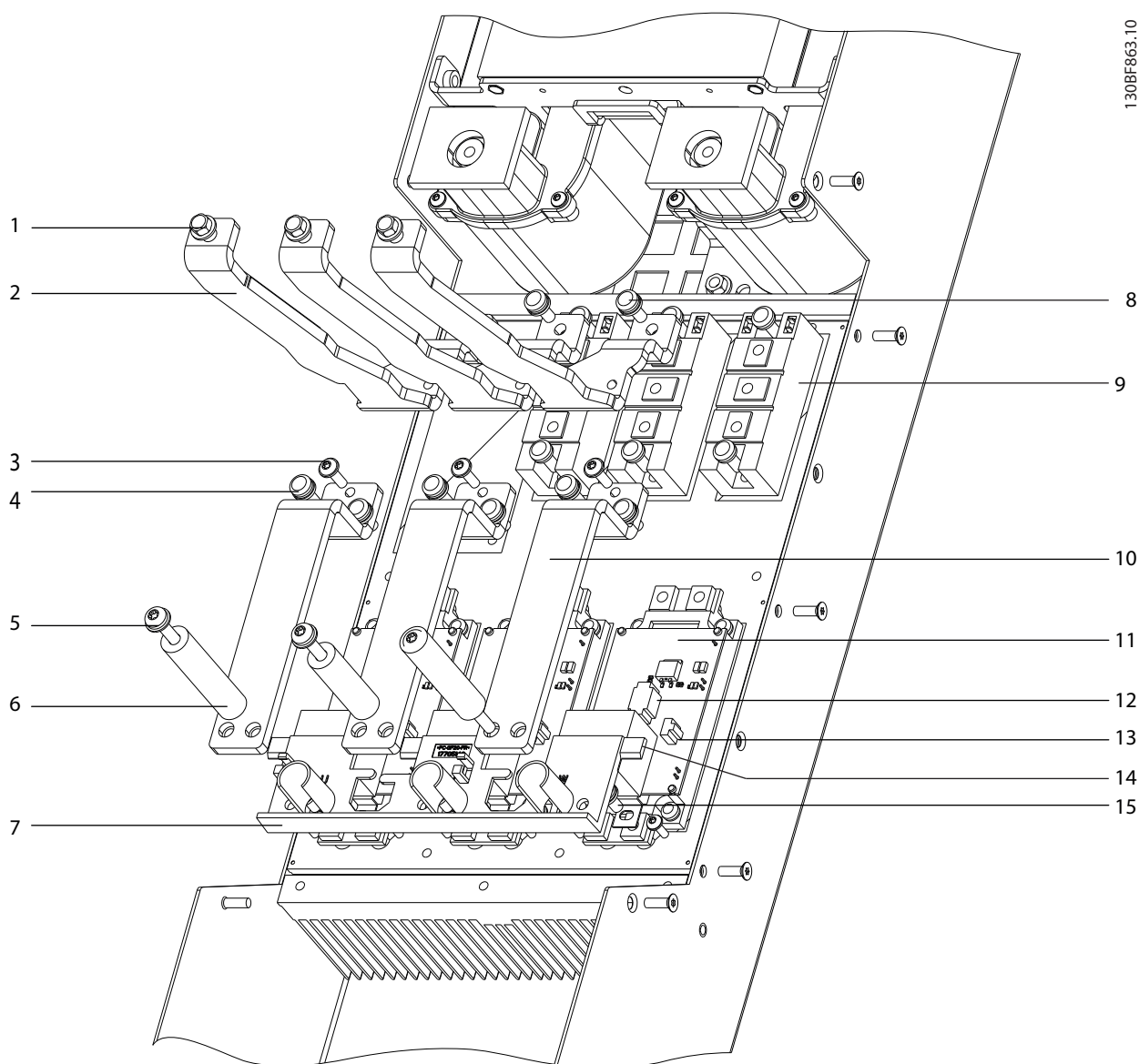

10

1	Nut (10 mm)	9	SCR module
2	SCR input busbar	10	IGBT output busbar
3	Thread-forming screw (T25)	11	IGBT module (1 of 3)
4	Screw (T30)	12	IGBT gate signal connector
5	Screw (T30)	13	IGBT thermal sensor connector
6	Current sensor cylinder busbar	14	Snubber capacitor
7	Cylinder busbar support bracket	15	Screw (T30)
8	Screw (T30)	-	-

Illustration 10.10 SCRs and IGBTs

10.2.17 Gate Drive Card

To remove or reinstall the gate drive card, use the following steps. Refer to *Illustration 10.11*.

Disassembly

1. Remove the DC bus rails. Refer to *chapter 10.2.13 DC Bus Rails*.
2. Unplug the cables from the following gate drive card connectors:
 - 2a MK100
 - 2b MK501
 - 2c MK601
 - 2d MK701
 - 2e MK102
 - 2f MK201 (if brake option is present)
3. Remove 6 thread-forming screws (T20).

Reassembly

Tighten hardware according to *chapter 14.1 Fastener Torque Ratings*.

1. Secure 6 thread-forming screws (T20) in the gate drive card.
2. Attach the cables to the following gate drive card connectors:
 - 2a MK100
 - 2b MK501
 - 2c MK601
 - 2d MK701
 - 2e MK102
 - 2f MK201 (if brake option is present)
3. Replace the DC bus rails. Refer to *chapter 10.2.13 DC Bus Rails*.

10.2.18 Brake IGBT Module

To remove or reinstall the brake IGBT module, use the following steps. Refer to *Illustration 10.11*.

Disassembly

1. Remove the gate drive card. Refer to *chapter 10.2.17 Gate Drive Card*.
2. Remove the mains input terminal block. Refer to *chapter 10.2.6 Mains Input Terminal Block*.
3. Remove the motor terminal block. Refer to *chapter 10.2.7 Motor Terminal Block*.
4. Remove 2 brake-to-DC link busbars. Refer to *chapter 10.2.13 DC Bus Rails*.
5. Remove 2 thread-forming screws (T20) from the top of the brake IGBT module.
6. Remove the brake snubber capacitor by removing 2 screws (T30), 1 from each busbar.
7. Remove 2 screws (T30) from the bottom of the brake IGBT module.
8. Remove 1 thread-forming screw (T25).
9. Remove 4 screws (T25), 1 from each corner of the IGBT module.

Reassembly

For reassembly, follow the replacement IGBT instructions. Tighten hardware according to *chapter 14.1 Fastener Torque Ratings*.

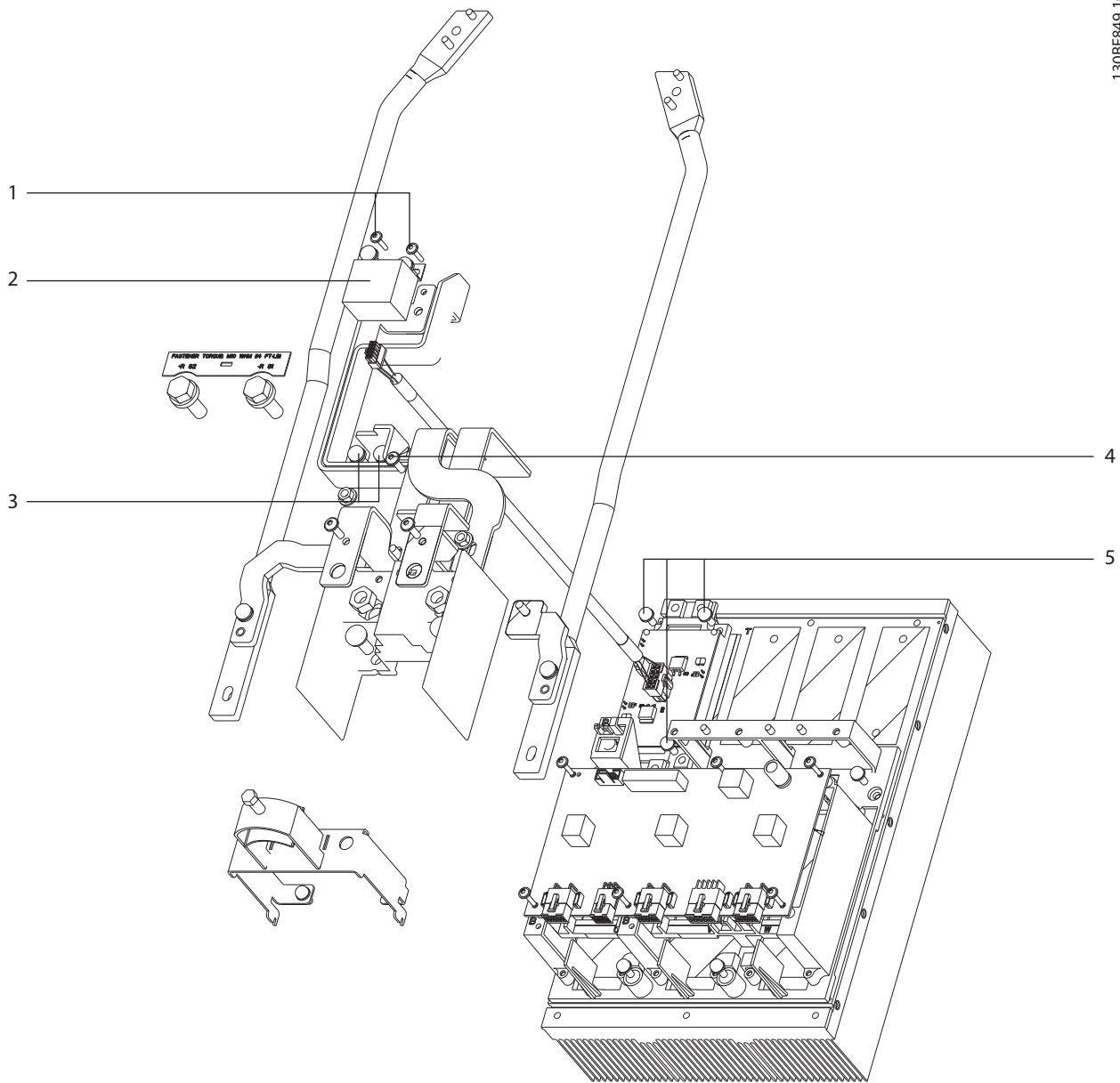

10

1	Thread-forming screws (T20)	4	Thread-forming screw (T25)
2	Snubber capacitor	5	Screws (T25)
3	Screws (T30)	-	-

Illustration 10.11 Brake IGBT Module

10.2.19 IGBTs

Disassembly in 240/400 V AC units

1. Remove the gate drive card. Refer to *chapter 10.2.17 Gate Drive Card*.
2. Remove the SCR input busbars. Refer to *chapter 10.2.15 SCR Input Busbars*.
3. Remove the balance/high frequency card. Refer to *chapter 10.2.12 Balance/High Frequency Card*.
4. Remove the insulation sheet from the capacitor bank.
5. Remove the cylinder busbar support bracket by removing 3 screws (T30).
6. Remove 1 thread-forming screw (T25) from each IGBT output busbar.
7. Remove the IGBT output busbar by removing 2 screws (T30), from each IGBT output busbar.
8. Disconnect the IGBT temperature cable from each IGBT module.
9. Remove the gate leads, 1 from each IGBT module.
10. Remove the snubber capacitor from each IGBT module by removing 2 screws (T30).
11. To remove the DC(-) plate:
 - 11a Remove 3 screws (T20) next to the IGBT modules.
 - 11b Unfasten 1 standoff (8 mm) connecting the plate to the negative terminal of capacitor 3.
 - 11c Remove the screws (T25) connecting the plate to the negative terminals of capacitors 4 and 5. The number of screws varies based on drive size.
12. Remove the insulator sheet between the DC(-) plate and the DC(+) and midplate.
13. To remove the DC(+) plate:
 - 13a Remove 3 screws (T20).
 - 13b Unfasten 1 standoff (8 mm) connecting the plate to the positive terminal of capacitor 2.
 - 13c Remove the screws (T25) connecting the plate to the positive terminals of capacitors 1 and 6. The number of screws varies based on drive size.
14. Remove the plastic IGBT support (not shown) by removing 4 screws (T25).
15. Remove the IGBTs by removing 4 screws (T25) from each IGBT.

Disassembly in 690 V AC units

1. Remove the gate drive card. Refer to *chapter 10.2.17 Gate Drive Card*.
2. Remove the SCR input busbars. Refer to *chapter 10.2.15 SCR Input Busbars*.
3. Remove the balance/high frequency card. Refer to *chapter 10.2.12 Balance/High Frequency Card*.
4. Remove the insulation sheet from the capacitor bank.
5. Remove the cylinder busbar support bracket by removing 3 screws (T30).
6. Remove 1 thread-forming screw (T25) from each IGBT output busbar.
7. Remove the IGBT output busbar by removing 2 screws (T30) from each IGBT output busbar.
8. Disconnect the IGBT temperature cable from each IGBT module.
9. Remove the gate leads, 1 from each IGBT.
10. Remove the snubber capacitor from each IGBT module by removing 2 screws (T30).
11. To remove the DC(-) plate:
 - 11a Remove 3 screws (T20 thread-forming) next to the IGBT modules.
 - 11b Remove 1 standoff (8 mm) connecting the plate to the negative terminal of capacitor 1.
 - 11c Remove 1 screw (T25) from the negative terminal of capacitor 3.
 - 11d Remove 1 round plastic alignment cap.
12. Remove the insulator sheet between the DC(-) plate and the DC(+) plate.
13. To remove the DC(+) plate:
 - 13a Remove 3 thread-forming screws (T20).
 - 13b Remove 2 screws (T25) connecting the plate to the positive terminals of capacitors 5 and 6.
14. Remove the plastic IGBT support (not shown) by removing 4 screws (T25).
15. Remove the IGBTs by removing 4 screws (T25) from each.

Reassembly

For reassembly, use the replacement IGBT instructions.

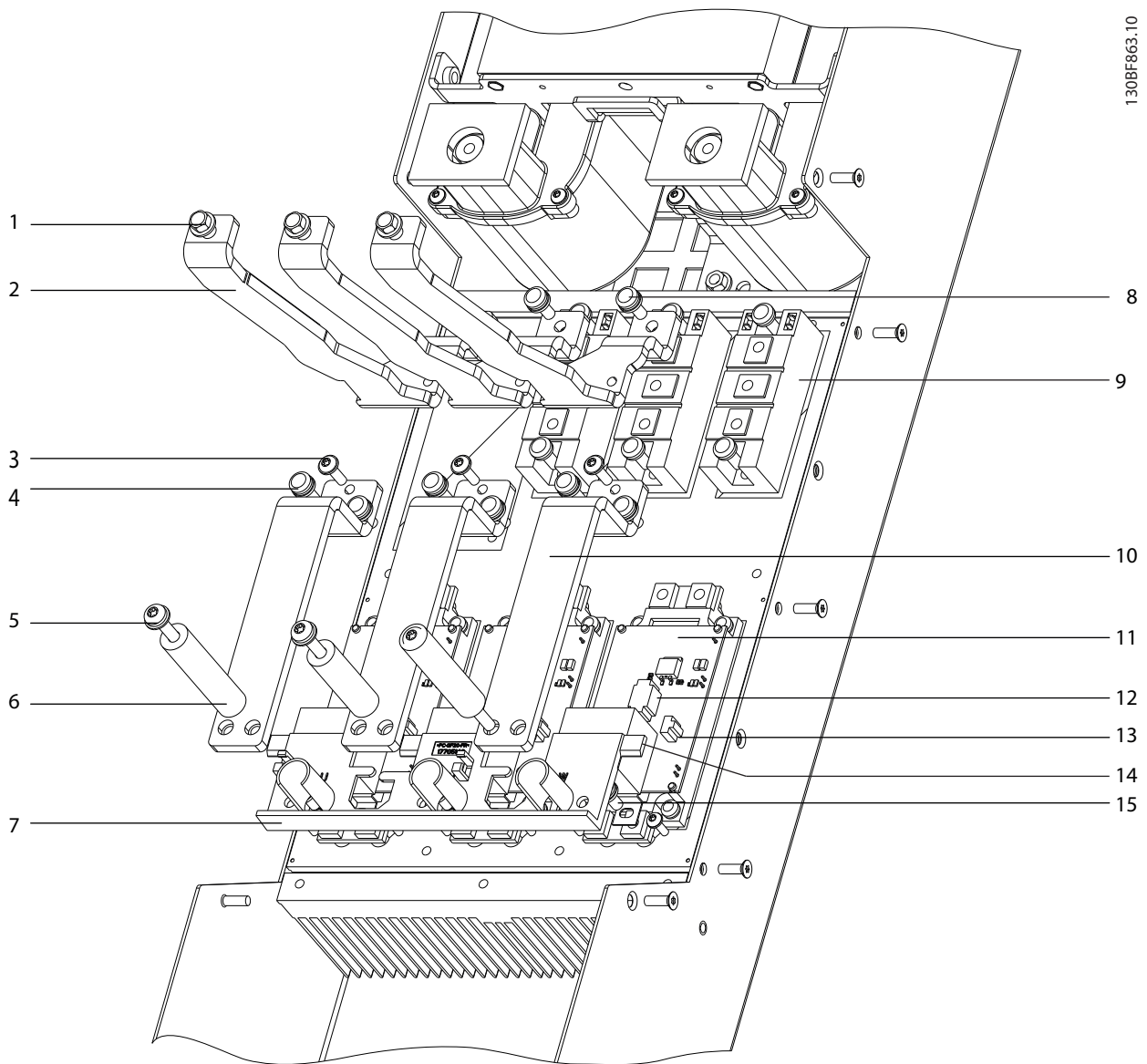

130BF863.10

10

1	Nut (10 mm)	9	SCR module
2	SCR input busbar	10	IGBT output busbar
3	Thread-forming screw (T25)	11	IGBT module (1 of 3)
4	Screw (T30)	12	IGBT gate signal connector
5	Screw (T30)	13	IGBT thermal sensor connector
6	Current sensor cylinder busbar	14	Snubber capacitor
7	Cylinder busbar support bracket	15	Screw (T30)
8	Screw (T30)	-	-

Illustration 10.12 SCRs and IGBTs

10.2.20 Standard DC Capacitors

To remove or reinstall the standard DC capacitors, use the following steps.

NOTICE

CAPACITOR REPLACEMENT

When replacing DC capacitors, always replace the entire bank of capacitors, even if only 1 DC capacitor has failed.

NOTICE

CAPACITOR TYPE

Drives can contain standard DC capacitors or twistlock capacitors. Use the standard DC capacitor instructions for drives manufactured prior to the following time period:

- 240/400 V AC units produced before week 18, 2018.
- 690 V AC units produced before week 23, 2018.

For excluded drives, see *chapter 10.2.22 Twistlock DC Capacitors*.

Disassembly in 240/400 V AC units

To remove or reinstall the standard DC capacitors, use the following steps. The number of fasteners may vary based on the drive size. Refer to *Illustration 10.13*.

1. Remove the gate drive card. Refer to *chapter 10.2.17 Gate Drive Card*
2. Remove the balance/high frequency card. Refer to *chapter 10.2.12 Balance/High Frequency Card*.
3. Remove insulator sheet 1.
4. Remove 3 screws (T30) from the cylinder busbar support bracket, and remove the bracket from the drive.
5. Remove 3 thread-forming screws (T25), 1 from the top of each IGBT output busbar.
6. Remove 6 screws (T30), 2 from the top of each IGBT output busbar. Remove the busbars from the drive.
7. Remove 6 screws (T30), 2 from each snubber capacitor. Remove the 3 snubber capacitors from the drive.
8. To remove the DC(-) plate:
 - 8a Remove 3 thread-forming screws (T20).
 - 8b Remove 1 standoff (8 mm). For reinstallation, mark the standoff locations on the plates with a felt-tip marker.
 - 8c Remove 2 screws (T25). Number of screws may vary based on drive size.
9. Remove insulator sheet 2.
10. To remove the DC(+) plate:
 - 10a Remove 3 thread-forming screws (T20).
 - 10b Remove 1 standoff (8 mm), and mark the location.
 - 10c Remove 2 screws (T25). Number of screws may vary based on drive size.
11. To remove the midplate:
 - 11a Remove 1 standoff (8 mm), and mark the location.
 - 11b Remove the screws (T25) from the remaining capacitors.
12. Remove the capacitor locking panel by removing 12 thread-forming screws (T25).
13. Lift the standard DC capacitors from the capacitor bank housing.

Reassembly in 240/400 V AC units

Tighten hardware according to *chapter 14.1 Fastener Torque Ratings*.

NOTICE**CAPACITOR POSITIONING**

For correct reassembly, ensure that the standard DC capacitor is seated on the retaining stud at the bottom of the capacitor slot.

1. Position the standard DC capacitors and plugs (if any) in the capacitor bank housing.
2. Replace the capacitor locking panel and fasten 12 thread-forming screws (T25).
3. To replace the midplate:
 - 3a Secure 1 standoff (8 mm) at the location previously marked on the midplate.
 - 3b Replace the screws (T25) in the remaining capacitors. Number of screws may vary based on drive size.
4. To replace the DC(+) plate:
 - 4a Fasten 3 thread-forming screws (T20).
 - 4b Secure 1 standoff (8 mm).
 - 4c Fasten 2 screws (T25). Number of screws may vary based on drive size.
5. Replace insulator sheet 2.
6. To replace the DC(-) plate:
 - 6a Fasten 3 thread-forming screws (T20).
 - 6b Secure 1 standoff (8 mm).
 - 6c Fasten 2 screws (T25). Number of screws may vary based on drive size.
7. Position 3 snubber capacitors in the drive and secure 6 screws (T30), 2 in each snubber capacitor.
8. Position the IGBT output busbars in the drive and secure 6 screws (T30), 2 in the top of each busbar.
9. Fasten 3 thread-forming screws (T25), 1 in the top of each IGBT output busbar.
10. Position the cylinder busbar support bracket in the drive and fasten with 3 screws (T30).
11. Replace insulator sheet 1.
12. Replace the balance/high frequency card. Refer to *chapter 10.2.12 Balance/High Frequency Card*.
13. Replace the gate drive card. Refer to *chapter 10.2.17 Gate Drive Card*

130BF864.10

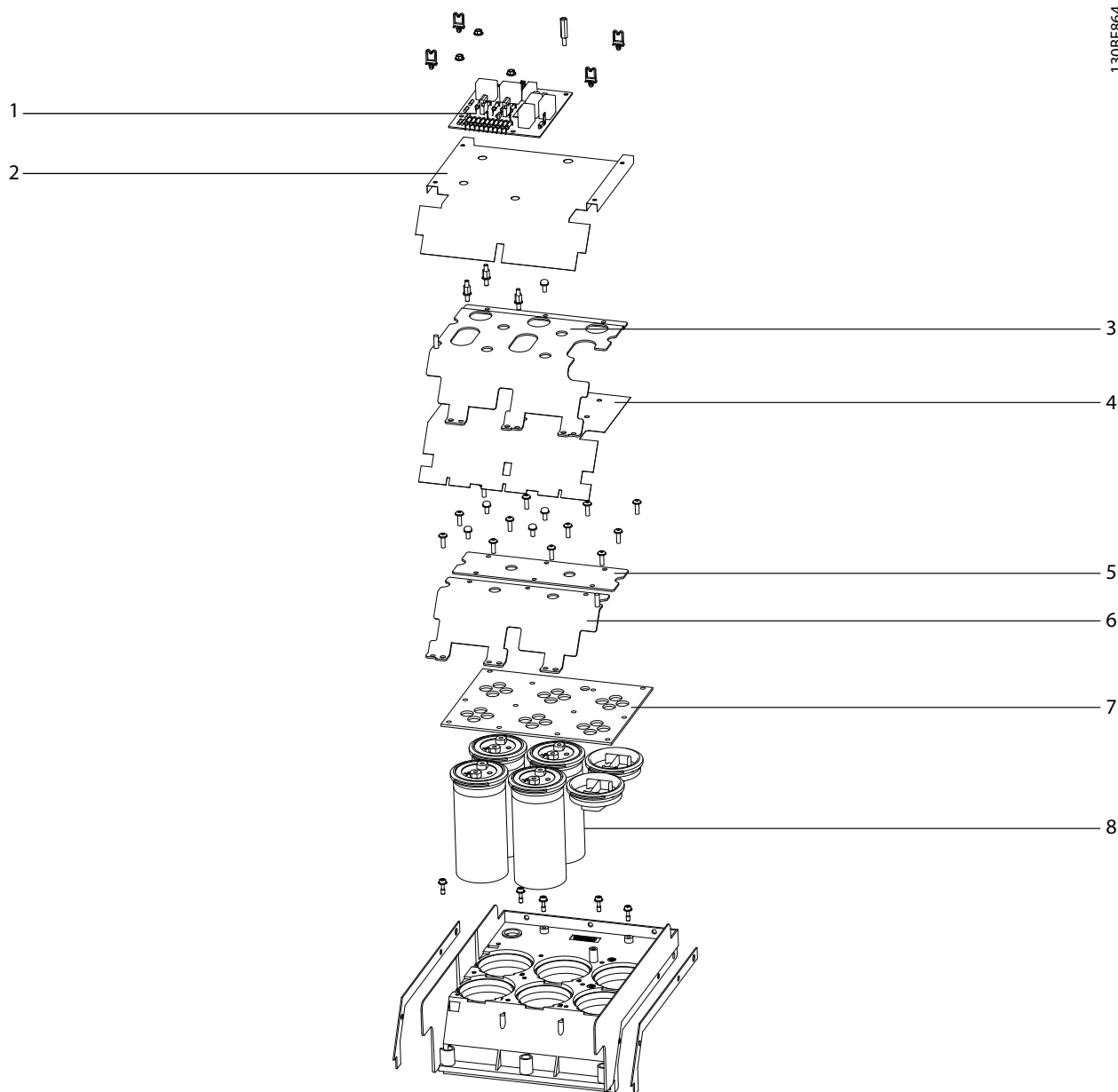

10

1	Balance/high frequency card	5	Midplate
2	Insulator sheet 1	6	DC(+) plate
3	DC(-) plate	7	Capacitor locking panel
4	Insulator sheet 2	8	Standard DC capacitor

Illustration 10.13 Standard DC Capacitor Bank, 240/400 V AC Unit

Disassembly in 690 V AC units

To remove or reinstall the standard DC capacitors, use the following steps. See *Illustration 10.14*.

1. Remove the gate drive card. Refer to *chapter 10.2.17 Gate Drive Card*
2. Remove the balance/high frequency card. Refer to *chapter 10.2.12 Balance/High Frequency Card*.
3. Remove insulator sheet 1.
4. Remove 3 screws (T30) from the cylinder busbar support bracket.
5. Remove 3 thread-forming screws (T25), 1 from each IGBT output busbar.
6. Remove 6 screws (T30), 2 from each IGBT output busbar. Remove the busbars from the drive.
7. Remove 6 screws (T30), 2 from each snubber capacitor. Remove the snubber capacitors from the drive.
8. To remove the DC(-) plate:
 - 8a Remove 3 thread-forming screws (T20).
 - 8b Remove 1 standoff (8 mm). For reinstallation, mark the locations of the standoffs on the plates with a felt-tip marker.
 - 8c Remove 1 screw (T25) from the negative terminal of capacitor 3.
 - 8d Remove 1 round plastic alignment cap.
9. Remove insulator sheet 2.
10. To remove the DC(+) plate:
 - 10a Remove 3 thread-forming screws (T20).
 - 10b Remove 2 screws (T25) from the positive terminals of capacitors 5 and 6.
11. Remove insulator sheet 3.
12. To remove midplate 1:
 - 12a Remove 1 standoff (8 mm), and mark the location.
 - 12b Remove 3 screws (T25) from the positive terminal of capacitor 2 and negative terminals of capacitors 5 and 6.
13. To remove midplate 2:
 - 13a Remove 1 standoff (8 mm), and mark the location.
 - 13b Remove 3 screws (T25) from the positive terminal of capacitor 1 and negative terminals of capacitors 2 and 4.
14. Remove the capacitor locking panel by removing 6 thread-forming screws (T25).
15. Lift the standard DC capacitors from the capacitor bank housing.

Reassembly in 690 V AC units

Tighten hardware according to *chapter 14.1 Fastener Torque Ratings*.

NOTICE

For correct reassembly, ensure that the DC capacitor is seated on the retaining stud at the bottom of the capacitor slot.

1. Position the standard DC capacitors in the drive.
2. Replace the capacitor locking panel and fasten 6 thread-forming screws (T25).
3. To replace midplate 2:
 - 3a Secure 1 standoff (8 mm) at the location previously marked on the midplate.
 - 3b Fasten 3 screws (T25) in the positive terminal of capacitor 1 and negative terminals of capacitors 2 and 4.
4. To replace midplate 1:
 - 4a Fasten 1 standoff (8 mm).
 - 4b Secure 3 screws (T25) in the positive terminal of capacitor 2 and negative terminals of capacitors 5 and 6.
5. Replace insulator sheet 3.
6. To replace the DC(+) plate:
 - 6a Fasten 3 thread-forming screws (T20).
 - 6b Secure 2 screws (T25) in the positive terminals of capacitors 5 and 6.
7. Replace insulator sheet 2.
8. To replace the DC(-) plate:
 - 8a Fasten 3 thread-forming screws (T20).
 - 8b Secure 1 standoff (8 mm).
 - 8c Fasten 1 screw (T25) in the negative terminal of capacitor 3.
 - 8d Replace 1 round plastic alignment cap.
9. Position 3 snubber capacitors in the drive, and secure 6 screws (T30), 2 in each snubber capacitor.
10. Position 3 IGBT output busbars in the drive, and fasten 6 screws (T30), 2 in each busbar.
11. Fasten 3 thread-forming screws (T25), 1 in each IGBT output busbar.
12. Position the cylinder busbar support bracket, and secure with 3 screws (T30).
13. Replace insulator sheet 1.
14. Replace the balance/high frequency card. Refer to *chapter 10.2.12 Balance/High Frequency Card*.

15. Replace the gate drive card. Refer to *chapter 10.2.17 Gate Drive Card*

130BF850.10

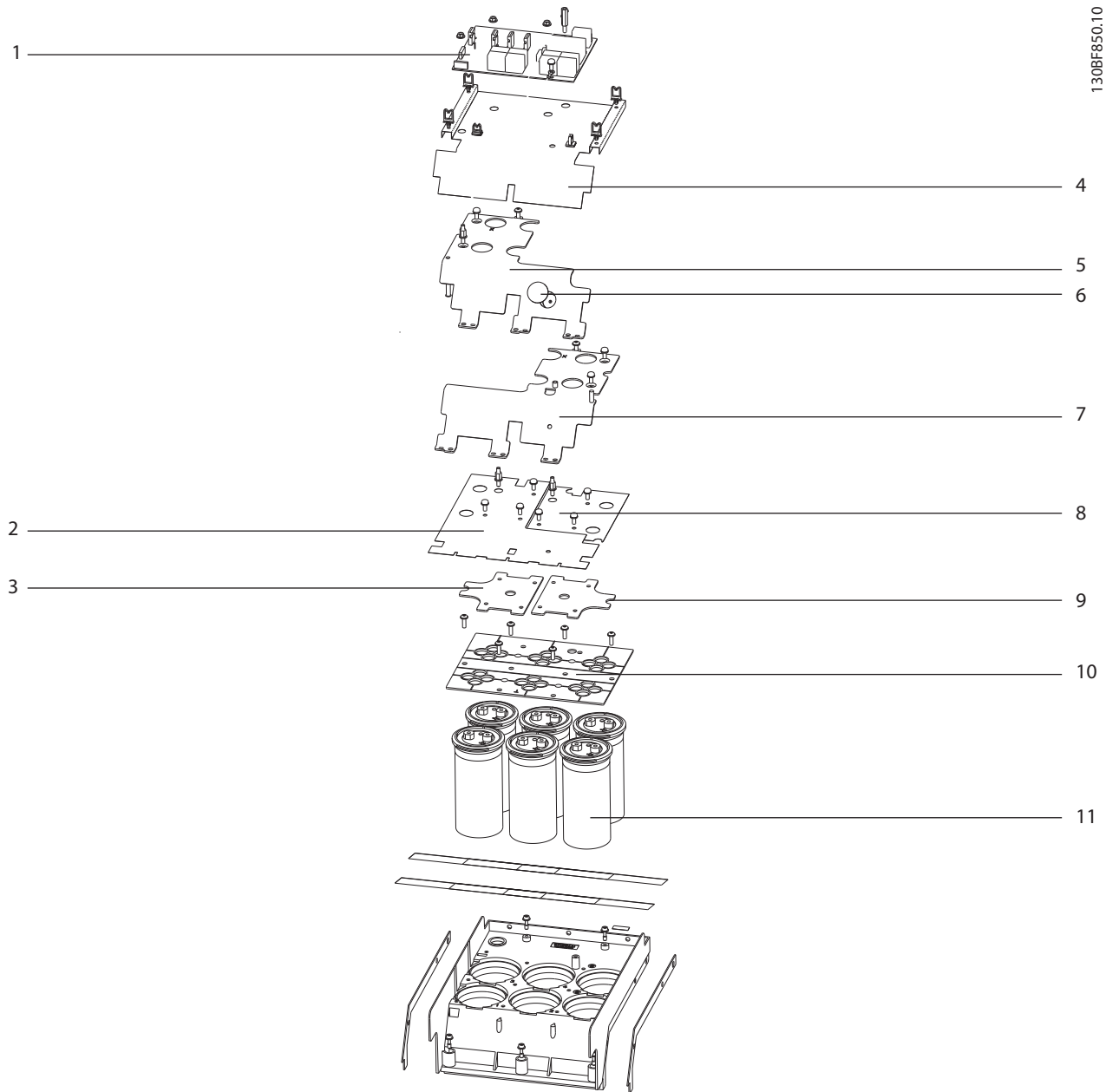

1	Balance/high frequency card	7	DC(+) plate
2	Insulator sheet 2	8	Insulator sheet 3
3	Midplate 1	9	Midplate 2
4	Insulator sheet 1	10	Capacitor locking panel
5	DC(-) plate	11	Standard DC capacitors
6	Plastic alignment cap	-	-

Illustration 10.14 DC Capacitors, 690 V AC Unit

10.2.21 Standard DC Capacitor Bank Layouts

Standard DC capacitor banks differ in the number of capacitors present and the location of fasteners, such as screws and standoffs. The drive size and power rating determine the layout of the capacitor bank. Use *Table 10.3* and *Table 10.3* to find the capacitor bank layout for a particular drive in D1h/D3h/D5h/D6h/J8 sizes. Each illustration includes a table that lists which fasteners are screws or standoffs, and which DC bus plate or midplate they secure.

Graphic reference	Model	
	FC 102, FC 103, and FC 202	FC 302
<i>Illustration 10.16</i>	N110	N90K
<i>Illustration 10.17</i>	N132	N110
<i>Illustration 10.17</i>	N160	N132

Table 10.3 Standard DC Capacitor Bank Layout 380–480/500 V

Graphic reference	Model	
	FC 102, FC 103, and FC 202	FC 302
<i>Illustration 10.17</i>	N75K	N55K
<i>Illustration 10.17</i>	N90K	N75K
<i>Illustration 10.17</i>	N110	N90K
<i>Illustration 10.17</i>	N132	N110
<i>Illustration 10.17</i>	N160	N132

Table 10.4 Standard DC Capacitor Bank Layout 525–690 V

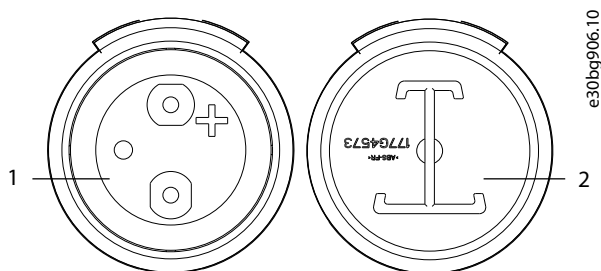

1	Standard DC capacitor
2	Plug

Illustration 10.15 Standard DC Capacitor and Plug

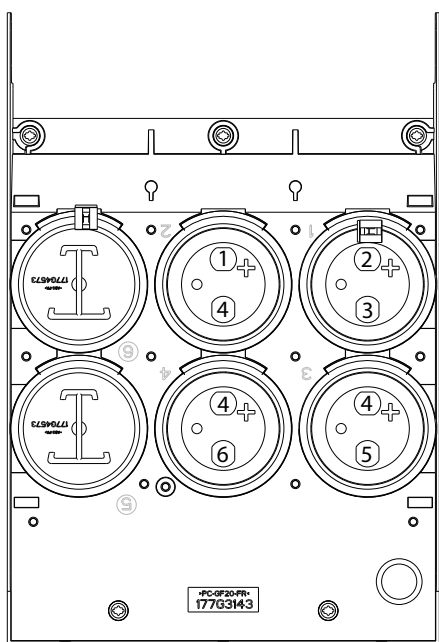

e30bc565.10

1	DC(+) plate standoff
2	DC(+) plate screw
3	Midplate standoff
4	Midplate screw
5	DC(-) plate standoff
6	DC(-) plate screw

Table 10.5

Illustration 10.16 Standard 4-Capacitor Layout

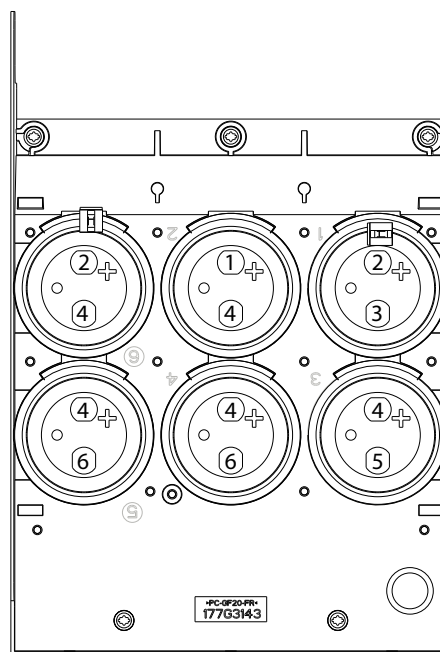

e30bc566.10

1	DC(+) plate standoff
2	DC(+) plate screw
3	Midplate standoff
4	Midplate screw
5	DC(-) plate standoff
6	DC(-) plate screw

Table 10.6

Illustration 10.17 Standard 6-Capacitor Layout

10.2.22 Twistlock DC Capacitors

To remove or reinstall the twistlock DC capacitors, use the following steps. See *Illustration 10.18* and *Illustration 10.19*.

NOTICE

CAPACITOR REPLACEMENT

When replacing capacitors, always replace the entire bank of capacitors, even if only 1 capacitor has failed.

NOTICE

CAPACITOR TYPE

Drives can contain standard DC capacitors or twistlock DC capacitors. Use the twistlock DC capacitor instructions for drives manufactured within the following time period.

- 240/400 V drives produced week 18, 2018 or after.
- 690 V drives produced week 23, 2018 or after.

For all other drives of this size, refer to *chapter 10.2.20 Standard DC Capacitors*.

Disassembly in 240/400 V AC units

See *Illustration 10.18*.

1. Remove the gate drive card. Refer to *chapter 10.2.17 Gate Drive Card*.
2. Remove the balance/high frequency card. Refer to *chapter 10.2.12 Balance/High Frequency Card*.
3. Remove insulator sheet 1.
4. Remove 3 screws (T30) from the cylinder busbar support bracket, and remove the bracket from the drive.
5. Remove 3 thread-forming screws (T25), 1 from each IGBT output busbar.
6. Remove 6 screws (T30), 2 from each IGBT output busbar.
7. Remove 6 screws (T30), 2 from each snubber capacitor.
8. To remove the DC(-) plate:
 - 8a Unfasten 3 thread-forming screws (T20) near the IGBT modules.
 - 8b Remove 1 standoff (8 mm) from the capacitors.
 - 8c Remove 2 screws (T25) from the capacitors.
9. Remove insulator sheet 2 by unfastening 8 screws (T25).

10. Remove the DC(+) plate by removing 3 thread-forming screws (T20) near the IGBT modules.
11. Remove the midplate by removing 1 standoff (8 mm).
12. Remove insulator sheet 3.
13. To remove a twistlock DC capacitor, use the special tool provided in the parts kit (or grip the edges with a large pliers).
14. Turn the twistlock DC capacitor approximately 30° counterclockwise to release it. Pull the capacitor out of the drive.

Reassembly in 240/400 V AC units

Start all fasteners with hand tightening, and then torque according to *chapter 14.1 Fastener Torque Ratings*.

1. Align the arrow on the rim of the twistlock DC capacitor with the arrow on the capacitor bank housing, and insert it into the drive.
2. Turn the DC capacitor clockwise approximately 30° until it locks in place. Check that the capacitor gasket is fully seated.
3. Position insulator sheet 3 over the capacitors.
4. Position the midplate on top of the insulator sheet.
5. Fasten 1 standoff in the midplate.
6. Place the DC(+) plate in the unit.
7. Position insulator sheet 2 over the midplate and DC(+) plate.
 - 7a Fasten 8 screws (T25) in the DC(+) plate.
 - 7b Fasten 3 thread-forming screws (T20).
8. Position the DC(-) plate in the unit.
 - 8a Fasten 3 thread-forming screws (T20) near the IGBT modules.
 - 8b Secure 2 screws (T25) in the plate.
 - 8c Fasten 1 standoff (8 mm).
9. Position the 3 snubber capacitors in the unit and fasten with 6 screws (T30), 2 per snubber capacitor.
10. Replace insulator sheet 1.
11. Replace the balance/high frequency card. Refer to *chapter 10.2.12 Balance/High Frequency Card*.
12. Replace the gate drive card. Refer to *chapter 10.2.17 Gate Drive Card*.

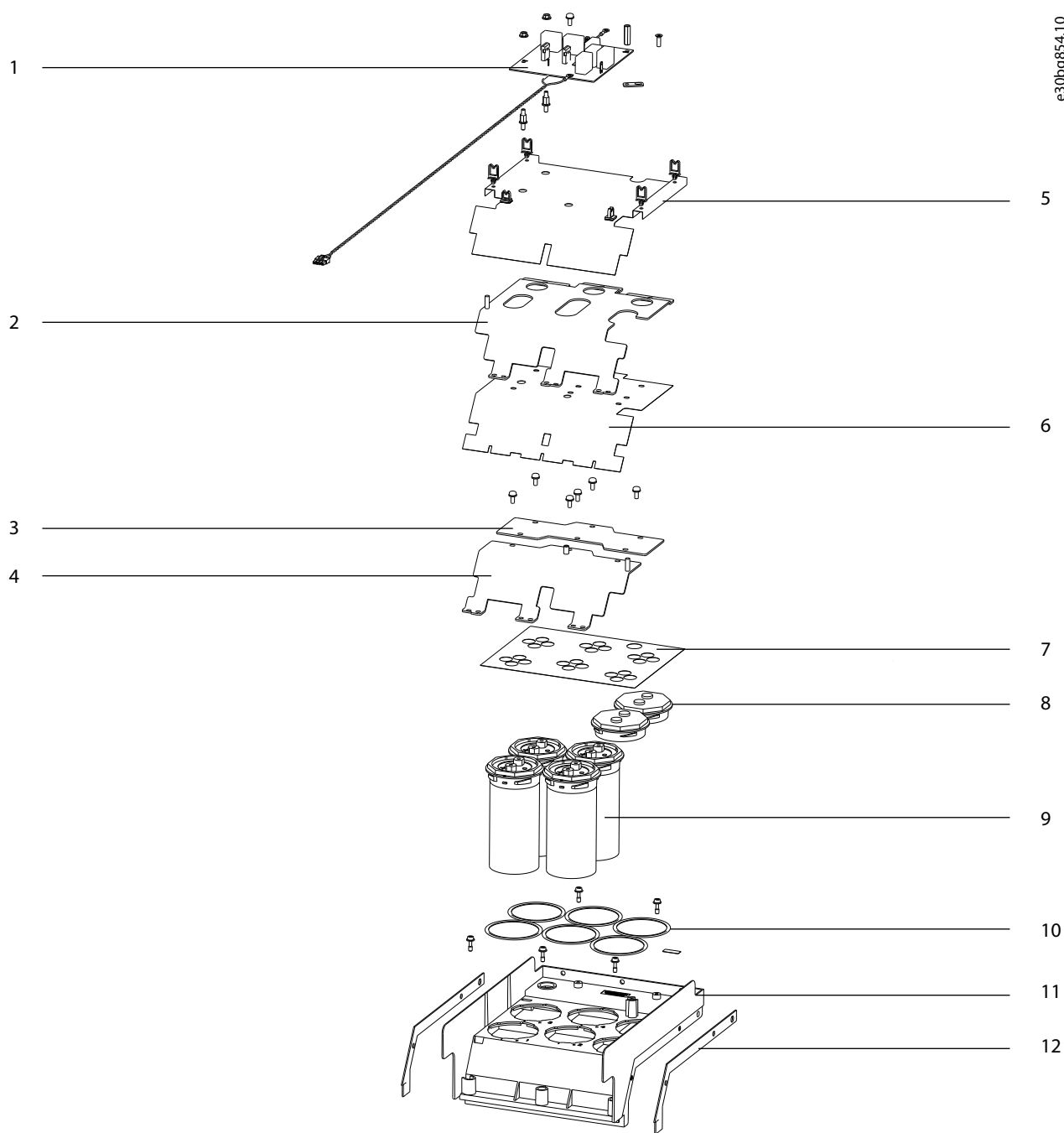

10

1	Balance/high-frequency card	7	Insulator sheet 3
2	DC(-) plate	8	Plug
3	Midplate	9	Twistlock DC capacitor
4	DC(+) plate	10	O-ring gasket
5	Insulator sheet 1	11	Capacitor housing
6	Insulator sheet 2	12	Housing gasket

Illustration 10.18 Twistlock DC Capacitor Bank, 240/400 V AC Unit

Disassembly in 690 V AC unitsSee *Illustration 10.19*.

1. Remove the gate drive card. Refer to *chapter 10.2.17 Gate Drive Card*.
2. Remove the balance/high frequency card. Refer to *chapter 10.2.12 Balance/High Frequency Card*.
3. Remove insulator sheet 1.
4. Remove 3 screws (T30) from the cylinder busbar support bracket.
5. Remove 3 thread-forming screws (T25), 1 from each IGBT output busbar.
6. Remove 6 screws (T30), 2 from each IGBT output busbar.
7. Remove 6 screws (T30), 2 from each snubber capacitor.
8. To remove the DC(-) plate:
 - 8a Remove 3 thread-forming screws (T20). Number of fasteners may vary based on drive size.
 - 8b Remove 1 standoff (8 mm).
 - 8c Remove 1 screw (T25).
 - 8d Remove 1 round plastic alignment cap.
9. Remove insulator sheet 2.
10. To remove the DC(+) plate:
 - 10a Remove 3 thread-forming screws (T20). Number of fasteners may vary based on drive size.
 - 10b Remove 2 screws (T25).
11. Remove insulator sheet 3.
12. To remove midplate 1:
 - 12a Remove 1 standoff (8 mm).
 - 12b Remove 3 screws (T25). Number of fasteners may vary based on drive size.
13. To remove midplate 2:
 - 13a Remove 1 standoff (8 mm).
 - 13b Remove 3 screws (T25). Number of fasteners may vary based on drive size.
14. Remove the capacitor locking panel by removing 6 thread-forming screws (T25).
15. To remove a twistlock DC capacitor, use the special tool provided in the parts kit (or grip the edges with a large pliers).
16. Turn the twistlock DC capacitor approximately 30° counterclockwise to release it. Pull the capacitor out of the housing.

Reassembly in 690 V AC unitsStart all fasteners with hand tightening, and then torque according to *chapter 14.1 Fastener Torque Ratings*.

1. Align the arrow on the rim of the twistlock DC capacitor with the arrow on the capacitor bank housing, and insert it into the drive.
2. Turn the capacitor clockwise approximately 30° until it locks in place. Check that the capacitor gasket is fully seated.
3. Replace the capacitor locking panel and fasten 6 thread-forming screws (T25).
4. To reinstall midplate 2:
 - 4a Fasten 1 standoff (8 mm).
 - 4b Secure 3 screws (T25). Number of fasteners may vary based on drive size.
5. To reinstall midplate 1:
 - 5a Fasten 1 standoff (8 mm).
 - 5b Secure 3 screws (T25). Number of fasteners may vary based on drive size.
6. Replace insulator sheet 3.
7. To replace the DC(+) plate:
 - 7a Fasten 3 thread-forming screws (T20). Number of fasteners may vary based on drive size.
 - 7b Secure 2 screws (T25).
8. Replace insulator sheet 2.
9. To replace the DC(-) plate:
 - 9a Secure 3 thread-forming screws (T20). Number of fasteners may vary based on drive size.
 - 9b Fasten 1 standoff (8 mm).
 - 9c Fasten 1 screw (T25).
 - 9d Attach 1 round plastic alignment cap.
10. Fasten 6 screws (T30), 2 in each snubber capacitor.
11. Secure 6 screws (T30), 2 in each IGBT output busbar.
12. Replace 3 thread-forming screws (T25), 1 in each IGBT output busbar.
13. Fasten 3 screws (T30) in the cylinder busbar support bracket.
14. Replace insulator sheet 1.
15. Replace the balance/high frequency card. Refer to *chapter 10.2.12 Balance/High Frequency Card*.
16. Replace the gate drive card. Refer to *chapter 10.2.17 Gate Drive Card*.

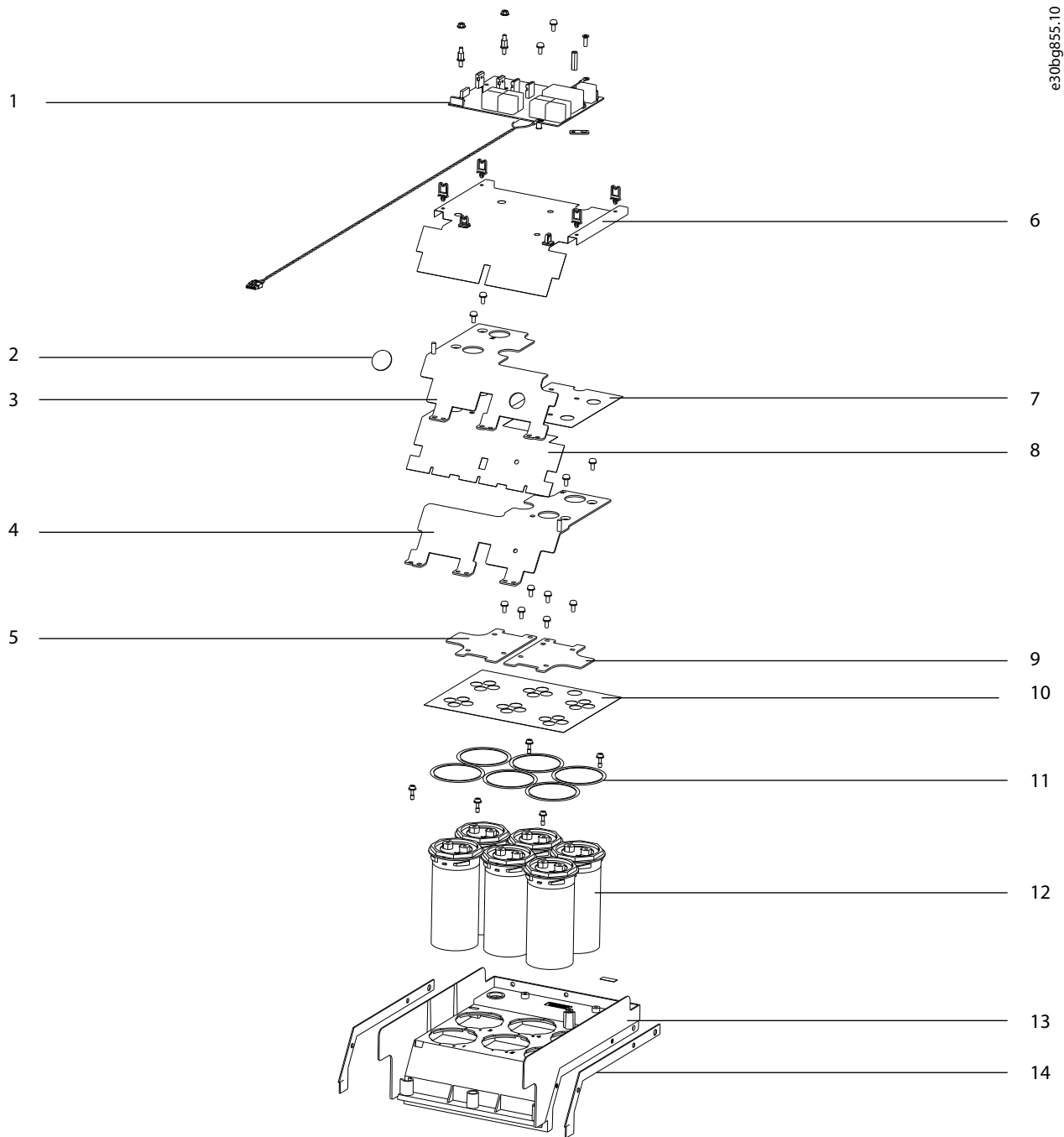

10

1	Balance/high frequency card	8	Insulator sheet 3
2	Plastic alignment cap	9	Midplate 2
3	DC(-) plate	10	Capacitor locking panel
4	DC(+) plate	11	O-ring gasket
5	Midplate 1	12	Twistlock DC capacitor
6	Insulator sheet 1	13	Capacitor bank housing
7	Insulator sheet 2	14	Capacitor bank gasket

Illustration 10.19 Twistlock DC Capacitors, 690 V AC Unit

10.2.23 Twistlock DC Capacitor Bank Layouts

Twistlock DC capacitor banks differ in the number of capacitors and plugs present and the location of fasteners, such as screws and standoffs. The drive size and power rating determine the layout of the twistlock DC capacitor bank. Use *Table 10.7* to *Table 10.9* to find the twistlock DC capacitor bank layout for a particular drive in D1h/D3h/D5h/D6h/J8 sizes.

Graphic reference	Model	
	FC 102, FC 103, and FC 202	FC 302
<i>Illustration 10.22</i>	N55K	N45K
<i>Illustration 10.22</i>	N75K	N55K

Table 10.7 Twistlock DC Capacitor Bank Layout 200–240 V

Graphic reference	Model	
	FC 102, FC 103, and FC 202	FC 302
<i>Illustration 10.21</i>	N110	N90K
<i>Illustration 10.22</i>	N132	N110
<i>Illustration 10.22</i>	N160	N132

Table 10.8 Twistlock DC Capacitor Bank Layout 380–500 V

Graphic reference	Model	
	FC 102, FC 103, and FC 202	FC 302
<i>Illustration 10.22</i>	N132	N110
<i>Illustration 10.22</i>	N160	N132

Table 10.9 Twistlock DC Capacitor Bank Layout 525–690 V

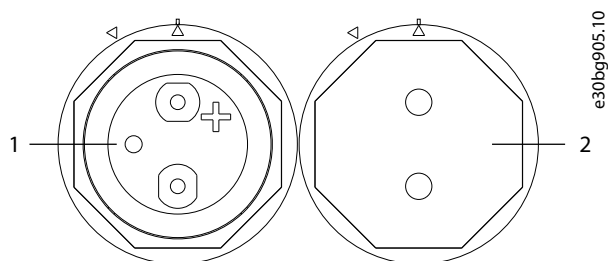

1	Twistlock DC capacitor
2	Plug

Illustration 10.20 Twistlock DC Capacitor and Plug

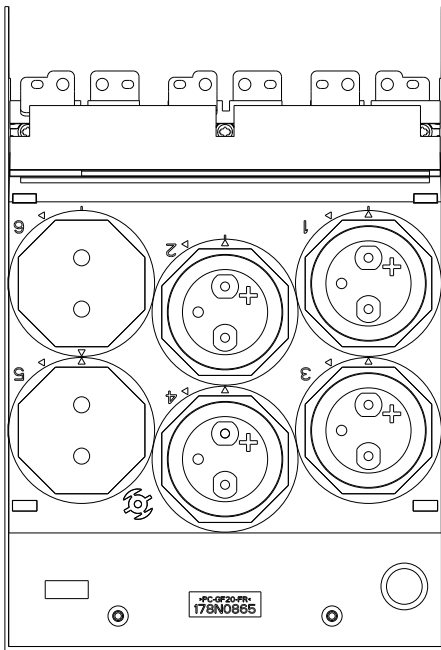

Illustration 10.21 Twistlock 4-Capacitor Layout

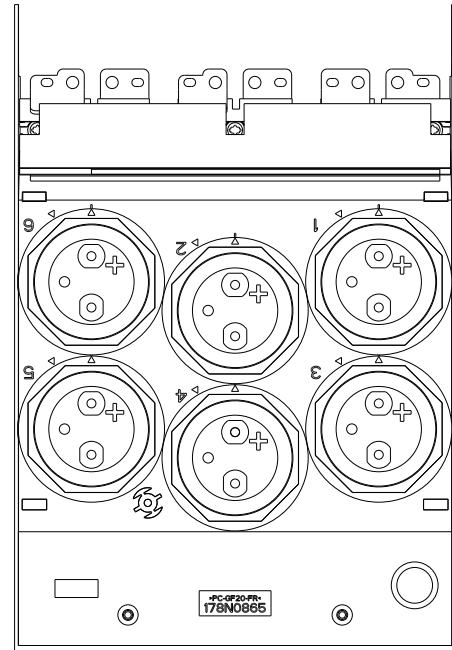

Illustration 10.22 Twistlock 6-Capacitor Layout

10.2.24 Heat Sink Fan

To remove or reinstall the heat sink fan, use the following steps. For IP21/IP54 (UL type 1/12) Drives, see *Illustration 10.24*. For IP20/Chassis drives, see *Illustration 11.32*.

NOTICE

HEAT SINK FAN ACCESS

If there is an extended options cabinet connected to the drive, see *chapter 10.3.1 Accessing the Heat Sink Fan in D5h/D6h Drives*.

Disassembly

1. To access the heat sink fan when an optional telescoping duct is installed:
 - 1a Remove 6 nuts (T25) from the duct flange that attaches the duct to the bottom of the drive. See *Illustration 10.23*.
 - 1b Lower the telescoping duct so that the heat sink fan cover is accessible.
2. Remove the heat sink fan cover by removing 2 captive screws (T25). Take care not to damage wiring inside the drive.
3. Lift the heat sink fan off the mounting studs and lift it out of the drive. The heat sink fan cable is still connected.
4. Squeeze together the top portion of the black rubber cable grommet until it pops through the hole, releasing the heat sink fan cable.
5. Disconnect the heat sink fan cable connector. To avoid dropping the end of the cable into the drive, affix the loose cable to the drive with adhesive tape.

Reassembly

Tighten hardware according to *chapter 14.1 Fastener Torque Ratings*.

1. Attach the heat sink fan cable connector to the fan cable.
2. Feed the fan cable back through the access hole. Press together the top of the rubber fan grommet until it pops into place in the hole.
3. Place the heat sink fan over the mounting studs.
4. Replace the heat sink fan cover by securing 2 captive screws (T25). Torque to 2.3 Nm (20 in-lb). If an optional telescoping duct is installed, extend the duct upward and secure the duct flange to the drive with 6 nuts (T25).

e30bg420.10

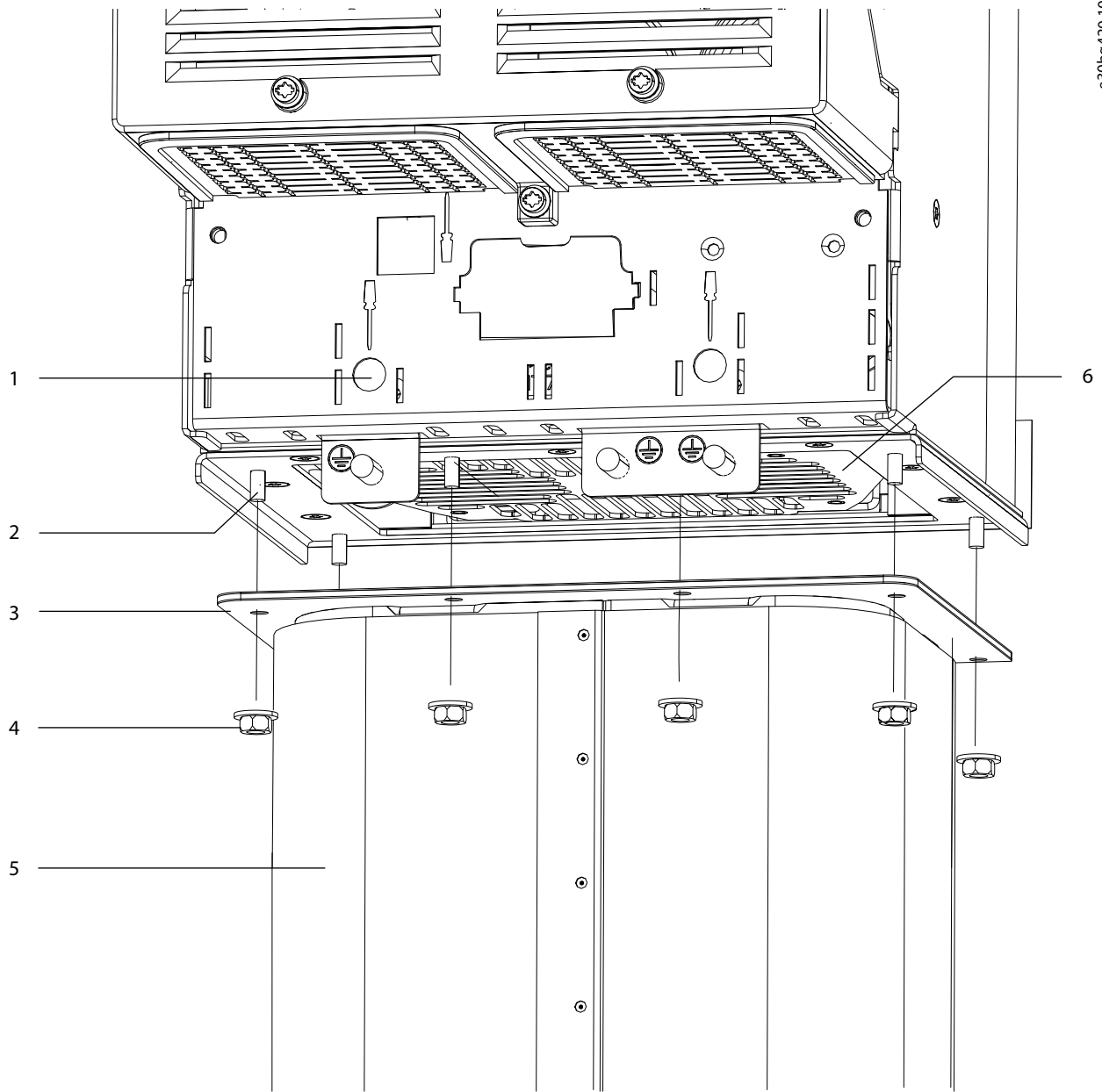

10

1	Screwdriver access holes for captive screws (T25)	4	Nut (T25)
2	Threaded stud	5	Telescoping duct
3	Duct flange	6	Heat sink fan cover

Illustration 10.23 Heat Sink Fan Access with Telescoping Cooling Duct

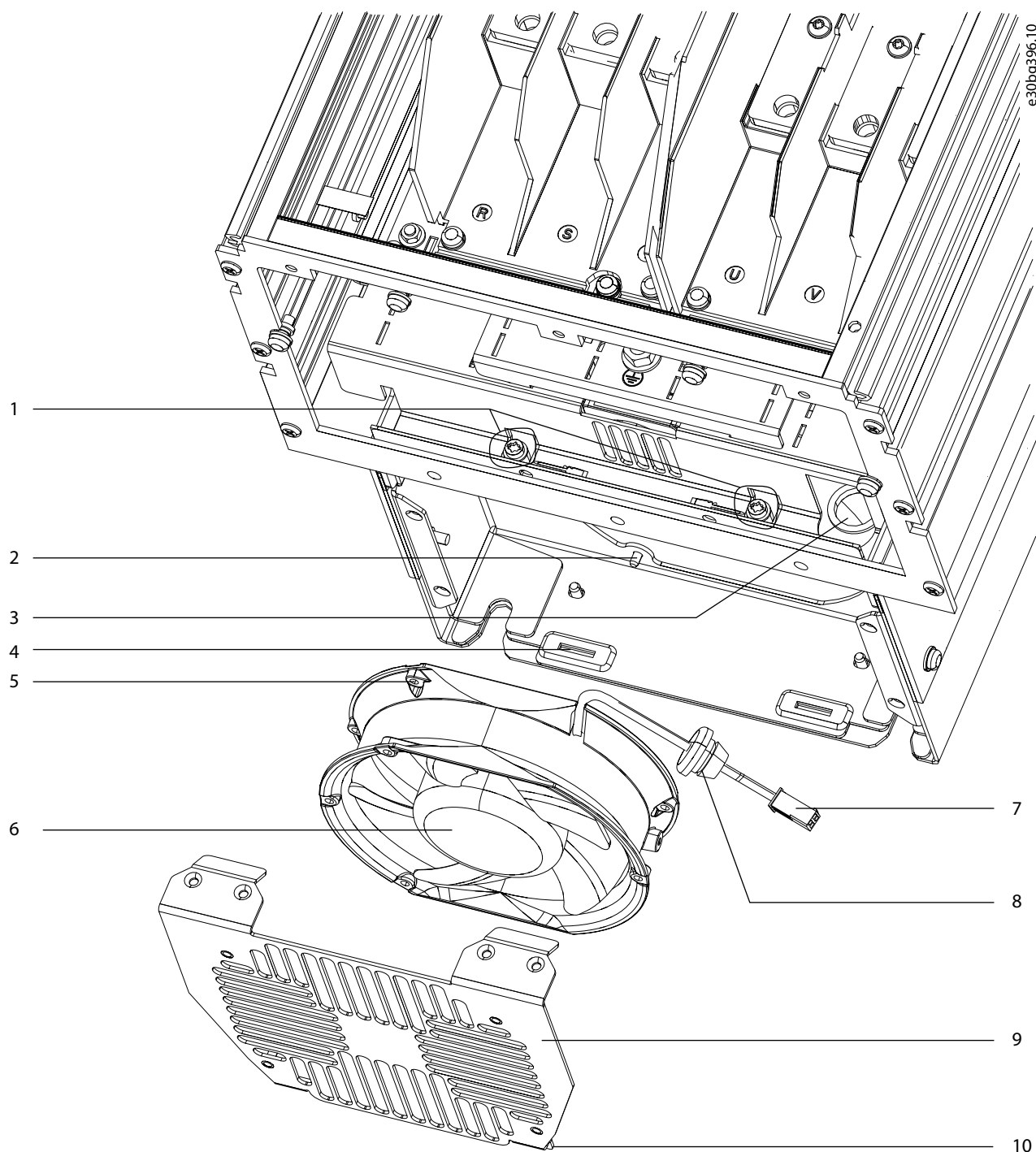

10

1	Captive screws (T25)	6	Heat sink fan
2	Mounting studs	7	Heat sink fan cable connector
3	Hole for cable grommet	8	Cable grommet
4	Slots for heat sink fan cover	9	Heat sink fan cover
5	Mounting holes	10	Fan cover tabs

Illustration 10.24 Heat Sink Fan in IP21/IP54 (UL type 1/12) Drives

10.2.25 Door Fan

Door fans are found in only IP21/IP54 (UL type 1/12) enclosures and extended option cabinets. To remove or reinstall a door fan, use the following steps. See *Illustration 10.25* and *Illustration 10.26*.

Disassembly

1. Pinch together the release tabs on the door fan front grill and remove the grill from the enclosure door.
2. Remove the door fan filter.
3. Open the enclosure door and unplug the in-line connector attaching the door fan cable.
4. Release the cable from the cable guides.
5. Detach 4 screws (T20) from the corners of the door fan. When removing the screws, hold each nut (7 mm) with a wrench on the opposite side of the door.
6. Remove the door fan from the enclosure door.
7. Using a pliers, pinch together the post in each corner of the door fan guard to release it from the fan.

NOTICE

FAN DIRECTION

To ensure proper cooling, position the door fan so that the air direction arrow points away from the internal drive components when the door is closed.

Reassembly

Tighten hardware according to *chapter 14.1 Fastener Torque Ratings*.

1. Align the posts on the door fan guard with the holes in the corners of the door fan and press together.
2. Position the door fan in the door of the enclosure. Check that the air direction arrow points away from the interior of the drive when the door is closed.
3. Replace 4 screws (T20) in the corners of the door fan, securing each with a nut (7 mm).
4. Route the door fan cable through the cable guides and attach the in-line cable connector.
5. Replace the filter over the door fan on the outside of the door.
6. Reposition the door fan grill over the filter and press until the grill snaps in place.

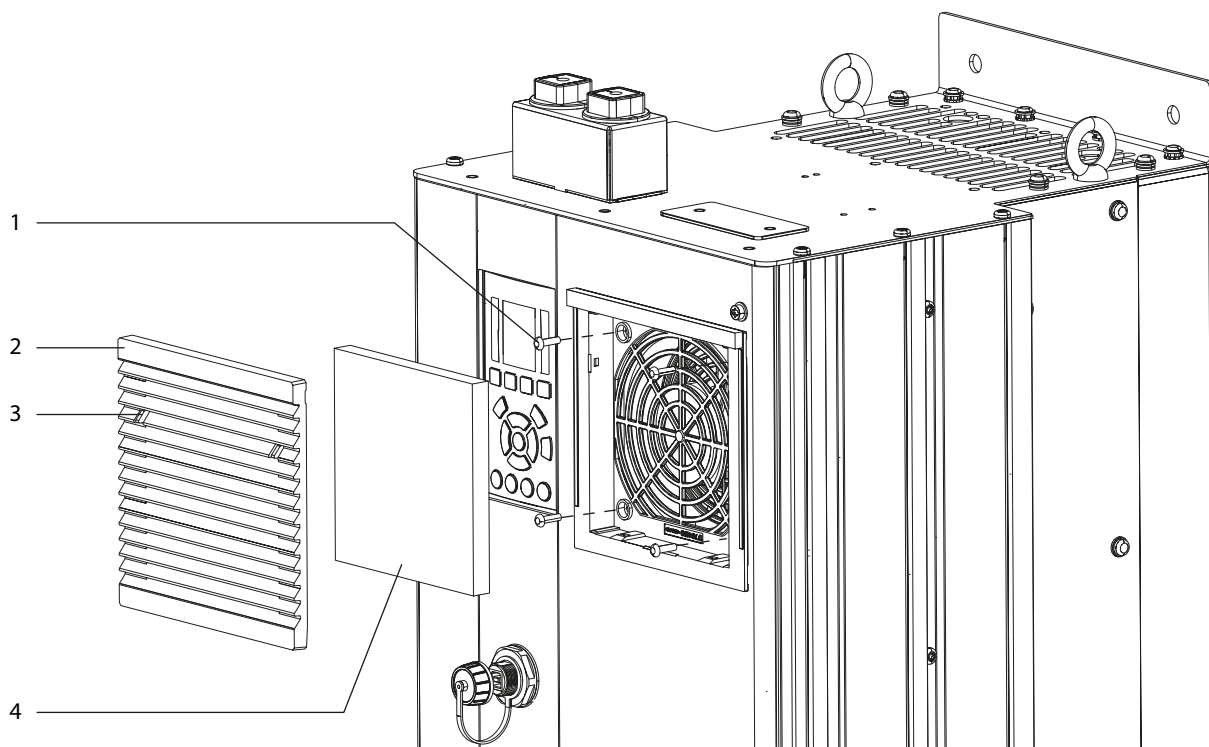

e30bg286.10

10

1	Screw (T20)	3	Release tab
2	Door fan front grill	4	Door fan filter

Illustration 10.25 Front View of Door Fan Assembly

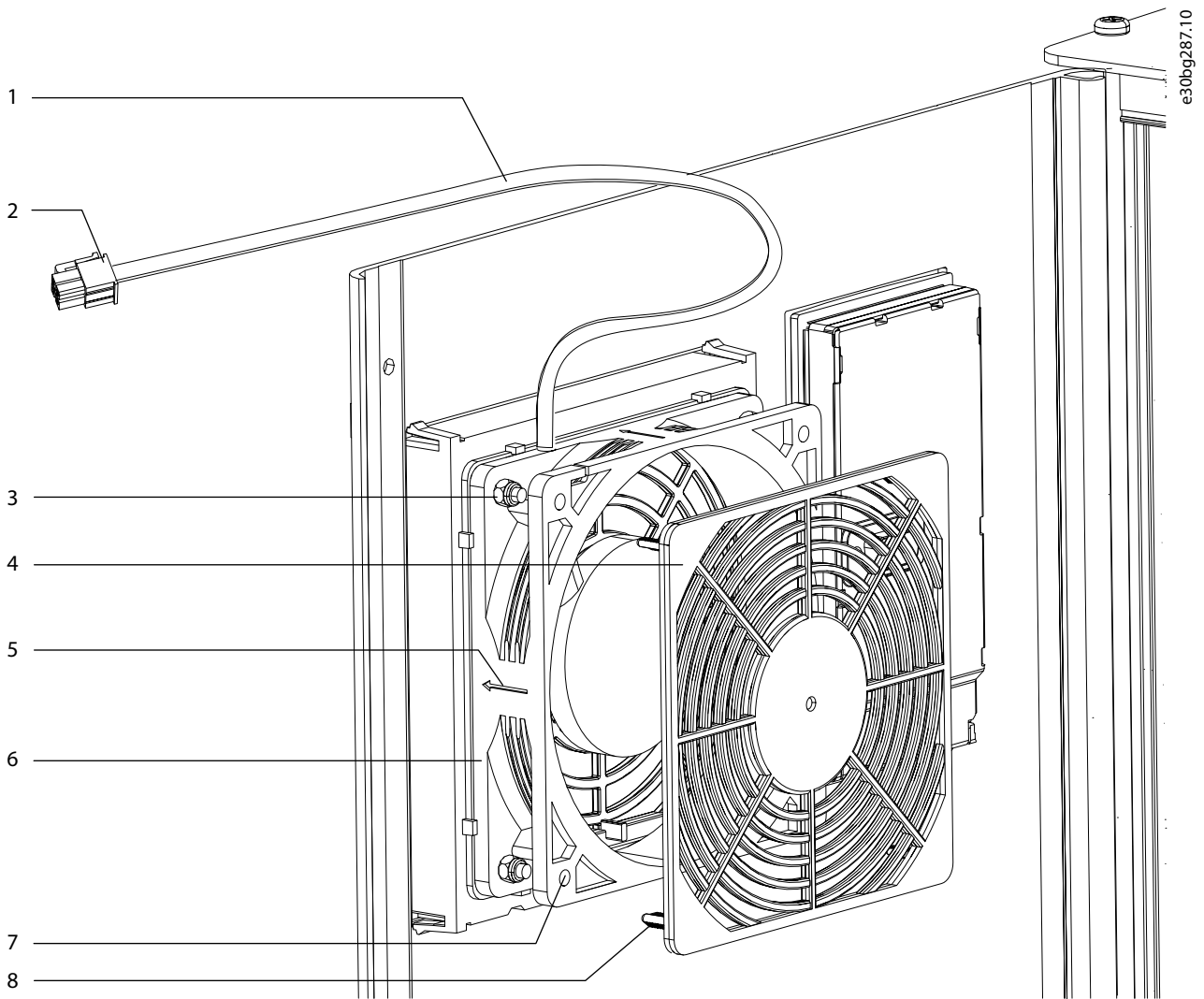

10

1	Door fan cable	5	Air direction arrow
2	Cable connector	6	Door fan
3	Nut (7 mm)	7	Hole for corner post
4	Door fan guard	8	Corner post

Illustration 10.26 Interior View of Door Fan Assembly

10.2.26 Top Fan

The top fan is present in IP20/Chassis units only. The top fan assembly includes 1 fan in a housing or secured under a sheet metal or wire grill. To remove or reinstall the top fan, use the following steps. See *Illustration 10.27* and *Illustration 10.28*.

Disassembly

1. Unfasten 2 screws (T25) and remove the front cover from the unit.
2. Unplug the top fan cable connector.
3. Pull the top fan cable through the cable access hole, freeing it from the enclosure.
4. If a fan housing is present, perform the following steps. See *Illustration 10.27*. Otherwise, proceed to the next step.
 - 4a Remove 2 screws (T25) from the top fan housing.
 - 4b Slide the fan housing and top fan free from the retaining clips on top of the drive.
5. If a wire or sheet metal grill is present, perform the following steps. See *Illustration 10.28*.
 - 5a Remove 2 screws (T25) from opposite corners of the top fan grill.
 - 5b Lift the grill and top fan from the drive.

Reassembly

Tighten hardware according to *chapter 14.1 Fastener Torque Ratings*.

1. Feed the top fan cable through the cable access hole on the top of the drive.
2. Reconnect the in-line fan cable connector.
3. If a fan housing is present, perform the following steps. See *Illustration 10.27*. Otherwise, proceed to the next step.
 - 3a Place the top fan in the fan housing. Check that the air direction arrows point upward and away from the drive.
 - 3b Slide the top fan housing and fan under the retaining clips on top of the drive.
 - 3c Fasten 2 screws (T25) in the top fan housing, securing it to the drive.
4. If a wire or sheet metal grill is present, perform the following steps. See *Illustration 10.28*.
 - 4a Position the fan on top of the drive. Check that the air direction arrows point upward and away from the drive.
 - 4b Place the grill on top of the fan.
 - 4c Fasten 2 screws (T25) in opposite corners of the grill, securing the top fan to the drive.
5. Replace the front cover on the drive, and fasten with 2 screws (T25).

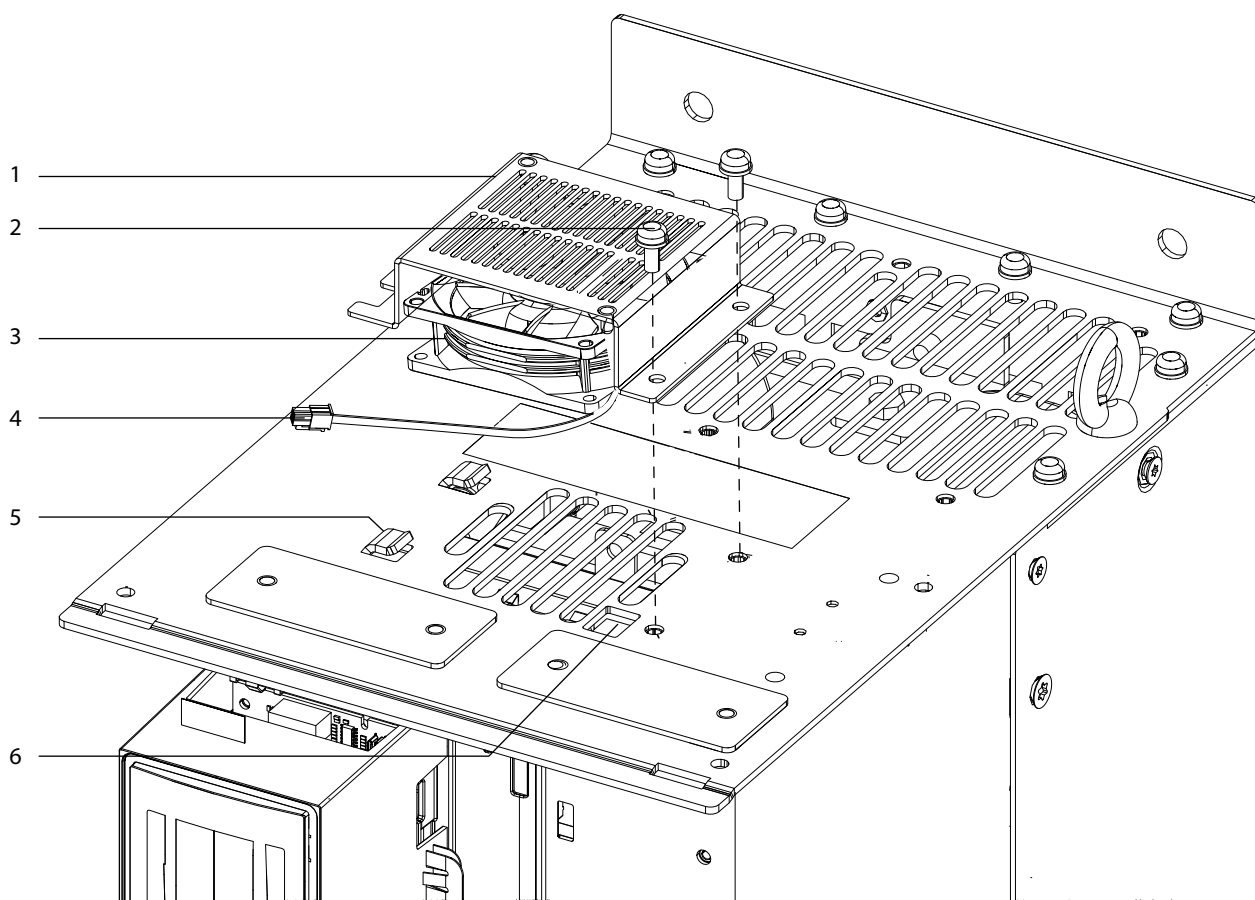

10

1	Top fan housing	4	Top fan cable and connector
2	Screw (T25)	5	Retaining clip
3	Top fan	6	Cable access hole

Illustration 10.27 Top Fan with Housing

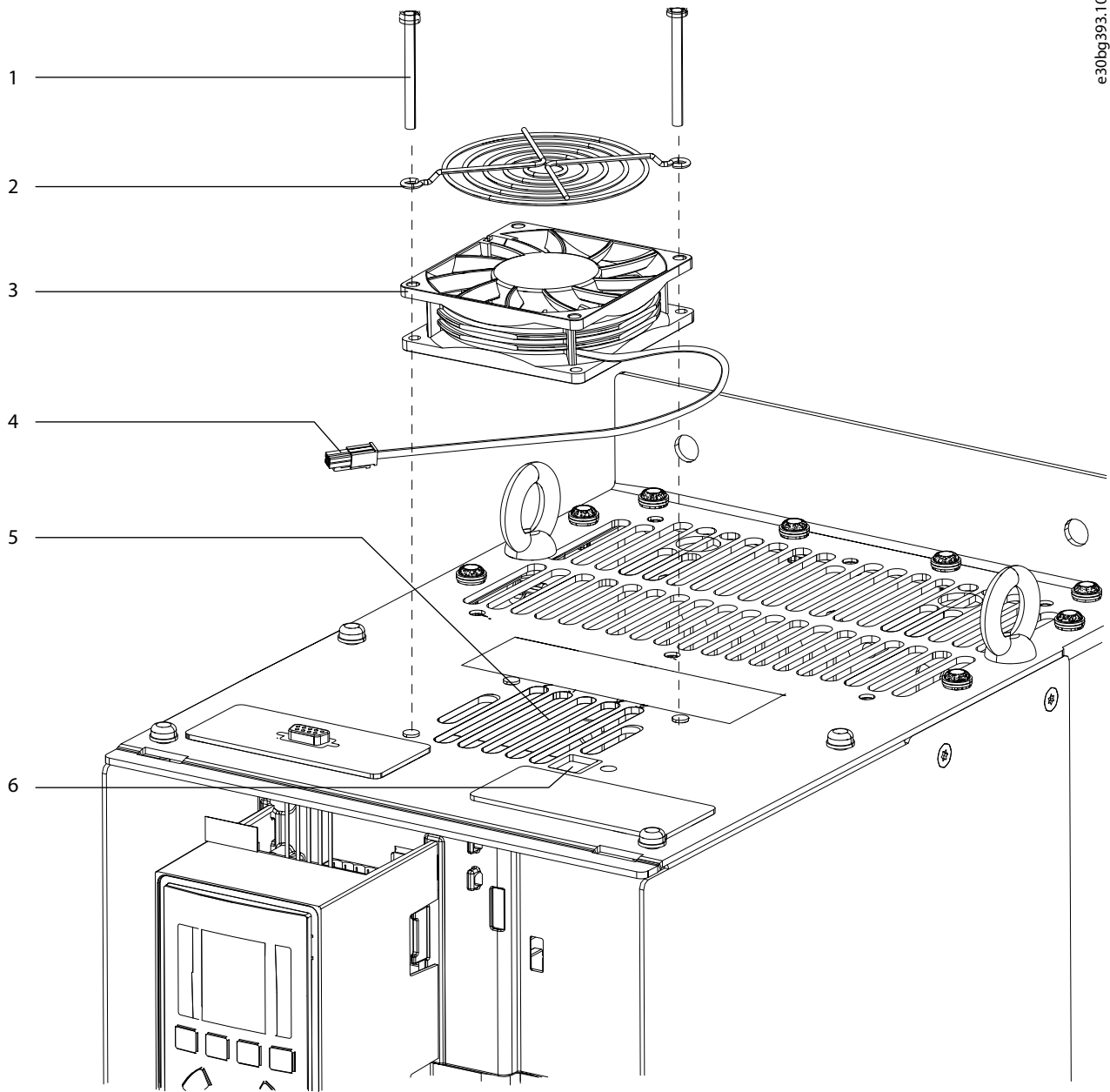

1	Screw (T25)	4	Top fan cable and connector
2	Top fan grill	5	Top vent
3	Top fan	6	Cable access hole

Illustration 10.28 Top Fan with Grill

10.3 D5h/D6h Disassembly and Assembly

The D5h and D6h drives are D1h drives with extended options cabinets. The drive profiled here includes a contactor, disconnect, and brake option, and is 690 V power range. Some procedures apply to all configurations, but some vary depending on the size of the enclosure, extended options cabinet, and selected options.

10.3.1 Accessing the Heat Sink Fan in D5h/D6h Drives

D5h and D6h drives include an extended options cabinet mounted below the heat sink fan. To access the heat sink fan in D5h/D6h drives, remove the busbars between the main enclosure and the extended options cabinet using the following steps. In drives with different option configurations, the busbars can vary slightly from the illustrations.

Disassembly

1. Remove the air baffle covering the interior components.
2. Remove the EMC shield by removing 2 screws (T25).
3. Remove the 3 mains input jumper busbars (R, S, and T) between the main enclosure and the extended options cabinet. See *Illustration 10.29*:
 - 3a Remove 3 screws (17 mm) from the top of the mains input jumper busbars, 1 per busbar.
 - 3b Remove 3 nuts (13 mm) from the bottom of the mains input jumper busbars, 1 per busbar.

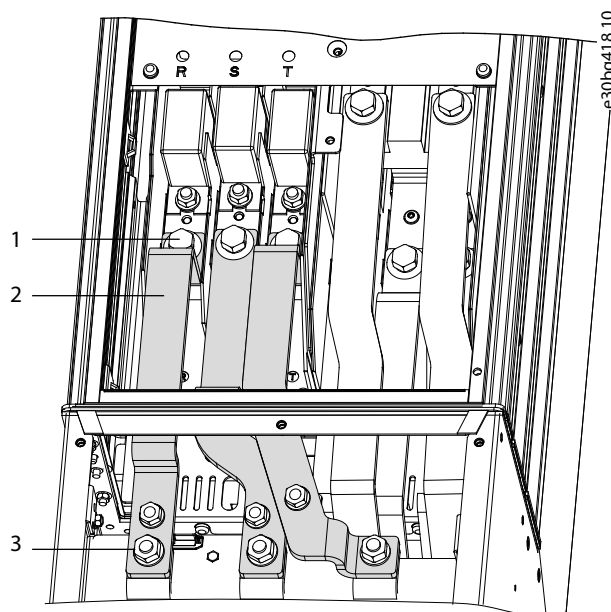

1	Screw (17 mm)
2	Mains input jumper busbars
3	Nut (13 mm)

Illustration 10.29 Mains Input Jumper Busbars in D5h/D6h

4. If optional brake is present, remove the 2 brake jumper busbars between the main enclosure and the extended options cabinet. See

Illustration 10.30:

- 4a Remove 2 nuts (17 mm) from the bottom end of the brake jumper busbars, 1 per busbar.
- 4b Remove 2 screws (17 mm) from the top end of the brake jumper busbars, 1 per busbar.

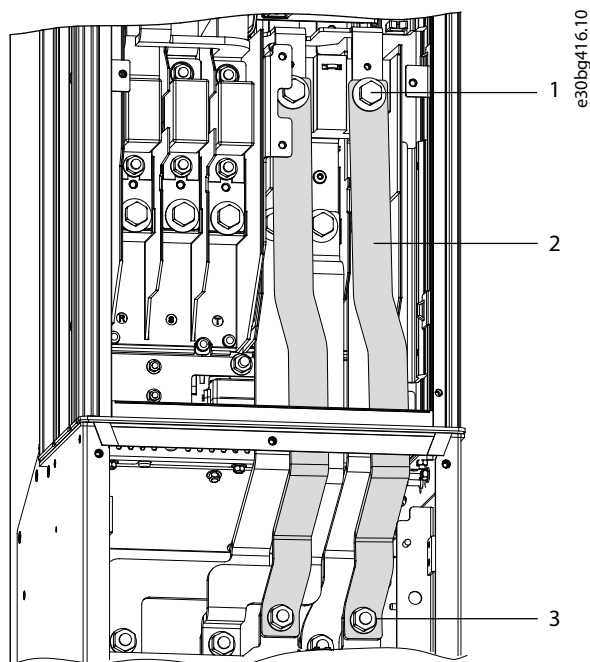

1	Screw (17 mm)
2	Brake jumper busbars
3	Nut (13 mm)

Illustration 10.30 Brake Jumper Busbars in D5h/D6h

5. Remove the 3 motor jumper busbars (U, V, and W) between the main enclosure and the extended options cabinet. See *Illustration 10.31:*

- 5a Remove 3 nuts (13 mm) at the bottom of the motor jumper busbars, 1 per busbar.
- 5b Remove 3 screws (17 mm) from the top of the motor jumper busbars, 1 per busbar.

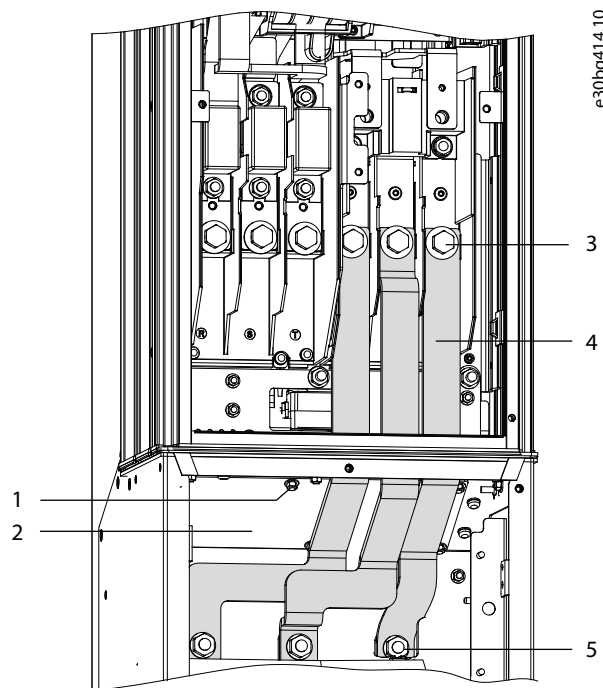

1	Nut (8 mm)
2	Fan access panel
3	Screw (17 mm)
4	Motor output jumper busbars
5	Nut (13 mm)

Illustration 10.31 Motor Jumper Busbars in D5h/D6h

6. Access the heat sink fan cover by removing 6 nuts (8 mm) from the fan access panel.
7. Lift the fan access panel from the extended options cabinet.
8. Remove the heat sink fan. See *chapter 10.2.24 Heat Sink Fan.*

Reassembly

Reinstall in reverse order of this procedure. Tighten hardware according to *chapter 14.1 Fastener Torque Ratings.*

10.3.2 Removing the Drive from the Extended Options Cabinet

To remove the drive from the extended options cabinet, use the following steps.

CAUTION

EXCESSIVE WEIGHT

The drive is heavy, weighing up to 62 kg (135 lb). To avoid injury, do not remove the drive from the extended options cabinet without assistance.

NOTICE

FASTENER REMOVAL

When removing the fasteners from the top flange, remove only the center 2 fasteners, which hold the drive and extended options cabinet together. The outer fasteners continue to support the extended options cabinet after the drive has been removed.

Disassembly

1. Remove the mains input jumper busbars, motor jumper busbars, and optional brake jumper busbars. Refer to *chapter 10.2 D1h/D3h/D5h/D6h/J8 Disassembly and Assembly*.
2. To remove the ground tie plate:
 - 2a Remove 3 nuts (13 mm) at the top of the plate inside the main enclosure.
 - 2b Remove 3 nuts (8 mm) at the bottom of the plate inside the option cabinet.
3. Remove 5 nuts (8 mm) inside the extended options cabinet from the bottom of the 3 brackets between the extended options cabinet and main enclosure.
4. Remove 2 connector plates from the top of the drive.
5. Lift the drive from the extended options cabinet.

Reassembly

Reinstall in reverse order of this procedure. Tighten hardware according to *chapter 14.1 Fastener Torque Ratings*.

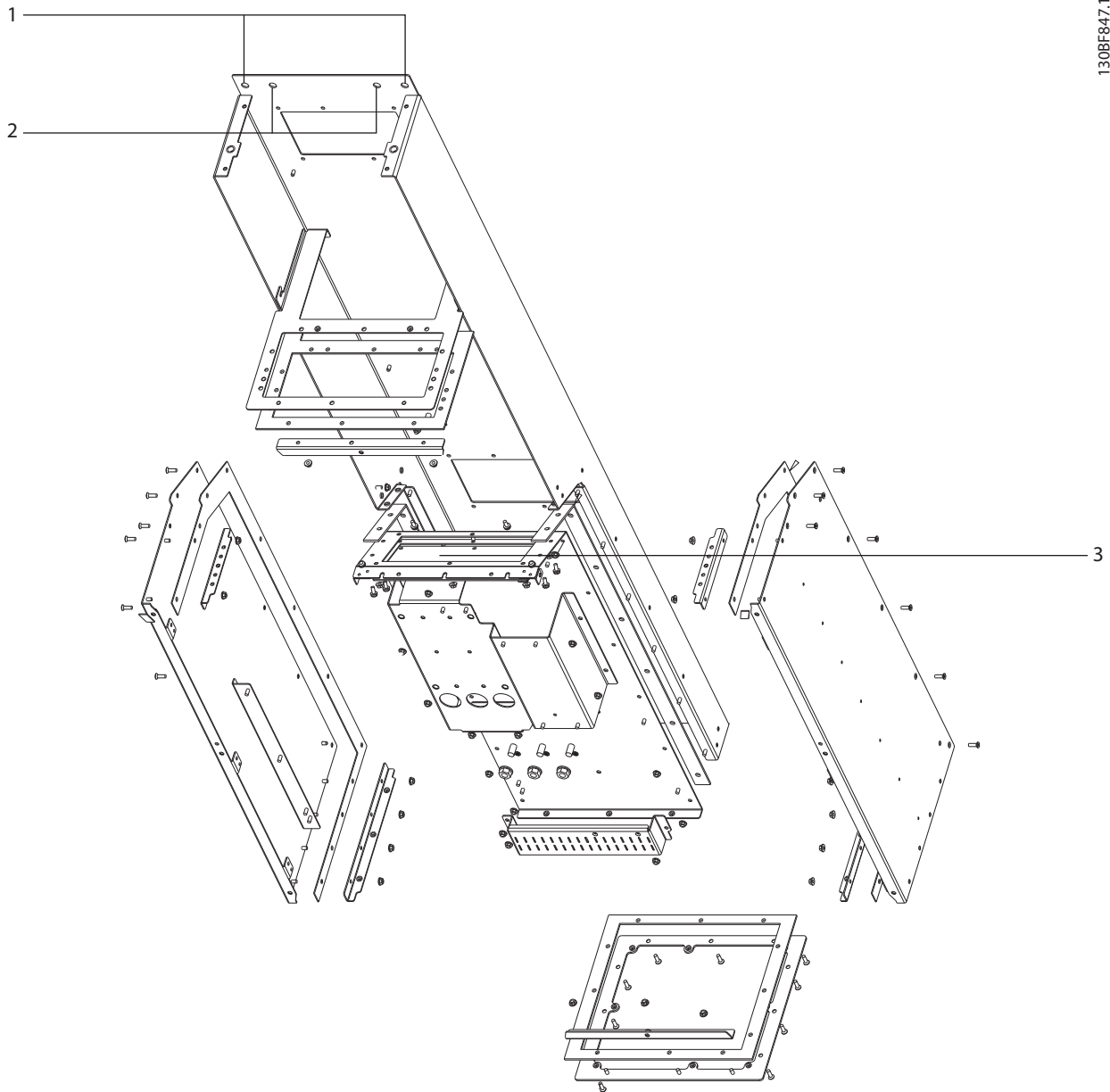

1	Extended options cabinet-to-wall fastener	3	Heat sink fan access panel
2	Extended options cabinet-to-drive fastener	-	-

Illustration 10.32 Extended Options Cabinet, Exploded View

10.3.3 Contactor

To remove or reinstall the contactor, use the following steps. Refer to *Illustration 10.33*.

Disassembly

1. Remove the AC input busbars. Refer to *chapter 11.2.5 AC Input Busbars*.
2. Remove fuses by removing 3 nuts (13 mm).
3. Remove the contactor coil wires from terminals A1 and A2.
4. Remove the contactor by removing 4 bolts (13 mm) that attach the contactor to the contactor bracket.

Reassembly

Reinstall in reverse order of this procedure. Tighten hardware according to *chapter 14.1 Fastener Torque Ratings*.

10.3.4 Disconnect

To remove or reinstall the disconnect, use the following steps. Refer to *Illustration 10.33*.

Disassembly

1. Remove the fuses. Refer to *chapter 11.2.5 AC Input Busbars*.
2. Remove the air baffle by removing 2 nuts (8 mm).
3. Remove 4 nuts (8 mm), 1 from each corner of the disconnect.
4. Lift the disconnect from the drive.

Reassembly

Reinstall in reverse order of this procedure. Tighten hardware according to *chapter 14.1 Fastener Torque Ratings*.

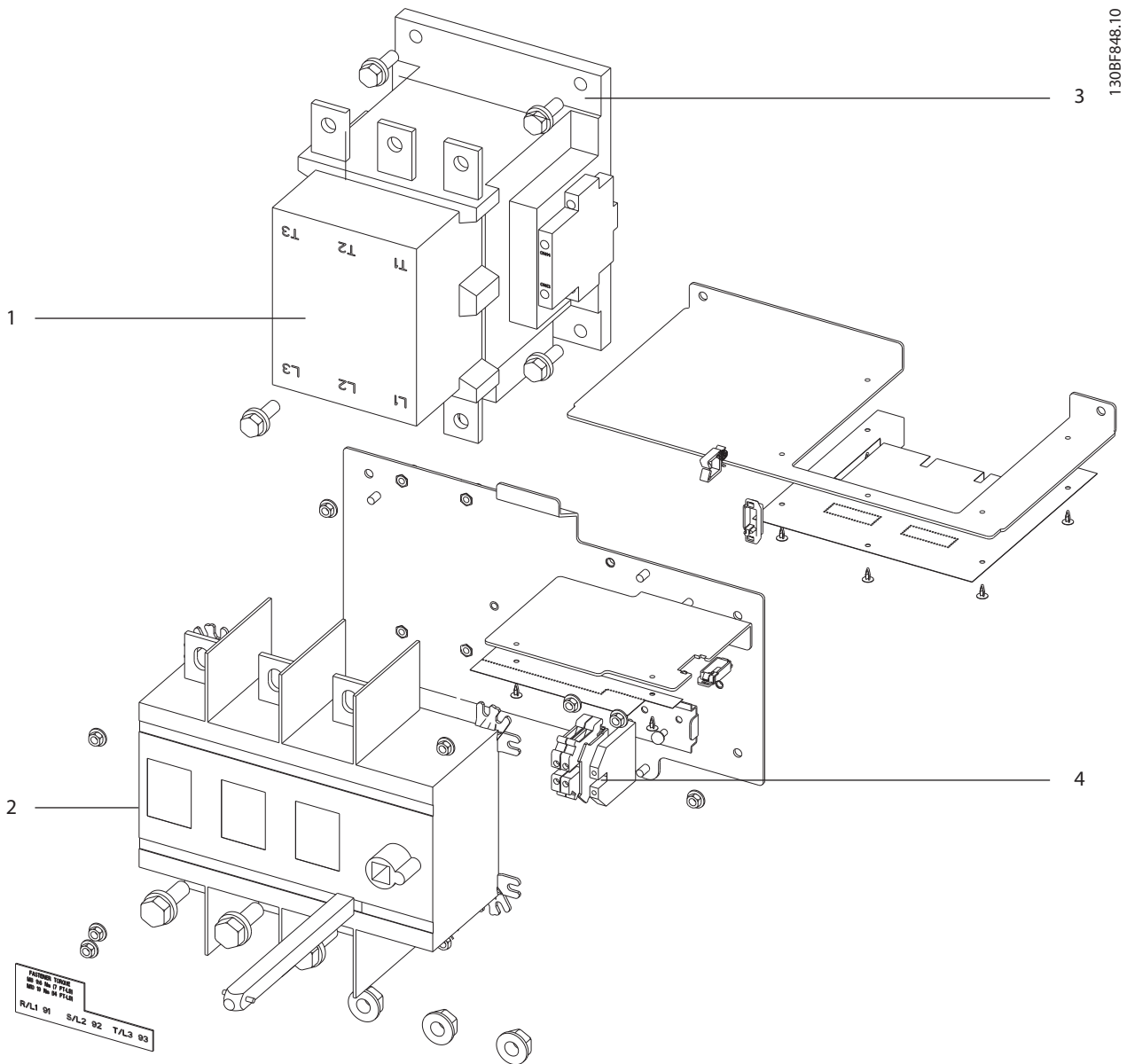

1	Contactor	3	Contactor bracket
2	Disconnect	4	A1/A2 contactor coil terminals

Illustration 10.33 D6h Contactor and Disconnect

10.4 Heat Sink Access Panel

10.4.1 Removing the Heat Sink Access Panel

The drive has an optional access panel for accessing the heat sink. To remove or reinstall the heat sink access panel, use the following steps. Refer to *Illustration 10.34*.

Disassembly

1. Do not power the drive while removing the heat sink access panel.
2. If the drive is mounted on a wall, or its back is otherwise inaccessible, reposition it to provide full access.
3. Remove the internal hex screws (3 mm) connecting the access panel to the back of the enclosure. There are 5 or 9 screws depending on the size of the drive.

Reassembly

Tighten fasteners according to *chapter 14.1 Fastener Torque Ratings*.

1. Do not power the drive while removing the heat sink access panel.
2. If the drive is mounted on a wall, or its back is otherwise inaccessible, reposition it to provide full access.
3. Fasten the internal hex screws (3 mm) connecting the access panel to the back of the enclosure. There are 5 or 9 screws depending on the size of the drive.

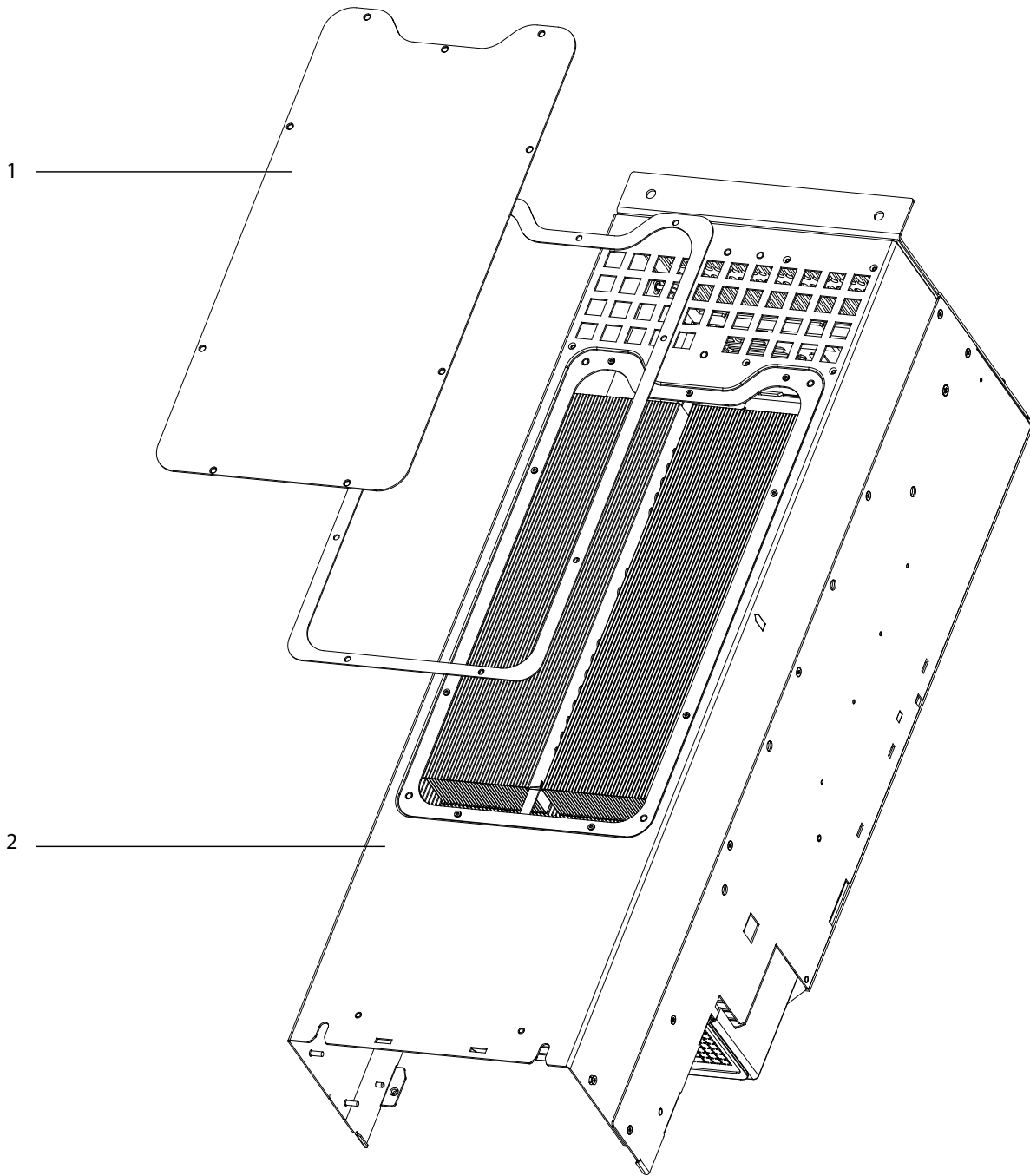

10

1	Heat sink access panel	2	Drive enclosure
---	------------------------	---	-----------------

Illustration 10.34 Heat Sink Access Panel

11 D2h/D4h/D7h/D8h/J9 Unit Disassembly and Assembly

11.1 Before Proceeding

Review all safety warnings and cautions in *chapter 2 Safety*.

- DO NOT touch electrical parts of the drive when connected to mains. Also make sure that other voltage inputs have been disconnected (linkage of DC intermediate circuit). There can be high voltage on the DC-link even when the indicator lights are turned off. Before touching any potentially live parts of the drive, wait at least 40 minutes.
- Before conducting repair or inspection, disconnect mains.
- [Off] on the LCP does not disconnect mains.
- During operation and while programming parameters, the motor can start without warning. Press [Stop] when changing data.
- When operating on a PM motor, disconnect the motor cable.

⚠ WARNING DISCHARGE TIME

The drive contains DC-link capacitors, which can remain charged even when the drive is not powered. High voltage can be present even when the warning LED indicator lights are off. Failure to wait the specified time after power has been removed before performing service or repair work can result in death or serious injury.

- Stop the motor.
- Disconnect AC mains and remote DC-link power supplies, including battery back-ups, UPS, and DC-link connections to other drives.
- Disconnect or lock the motor.
- Disconnect any brake option.
- Disconnect any regen/load share option.
- Wait for the capacitors to discharge fully. The minimum waiting time is specified in the following discharge time table and is also visible on the drive label.
- Before performing any service or repair work, use an appropriate voltage measuring device to make sure that the capacitors are fully discharged. For parallel drive modules, measure DC-bus capacitor voltages before and after the individual DC fuses.

Enclosure Size	Minimum waiting time
D1h–D8h drives	20 minutes
J8–J9 drives	20 minutes
D9h–D10h enclosed drive systems	20 minutes
Da2/Da4/Db2/Db4 parallel drive systems	20 minutes
E1h–E4h drives	40 minutes
E5h–E6h enclosed drive systems	40 minutes

Table 11.1 Discharge Time

⚠ WARNING

SHOCK HAZARD

The following options are powered before the optional circuit breaker or disconnect. Even with the circuit breaker or disconnect in the OFF position, mains voltage is still present inside the drive enclosure.

Failure to turn off the main service line/power to the drive before working on the following options can result in death or serious injury:

- Door interlock
- Space heater
- Cabinet light and outlet
- RCD monitor
- IRM monitor
- Emergency stop
- 24 V DC customer supply

NOTICE

INTERLOCKED DOORS

If supplied with a circuit breaker or disconnect switch, the cabinet doors are interlocked. To open the cabinet doors, set the circuit breaker and disconnect switch to the OFF position.

NOTICE

ELECTROSTATIC DISCHARGE (ESD)

Many electronic components within the drive are sensitive to static electricity. Voltages so low that they cannot be felt, seen, or heard can be harmful to electronic components. Use standard ESD protective procedures whenever handling ESD sensitive components. Failure to conform to standard ESD procedures can reduce component life, diminish performance, or completely destroy sensitive electronic components.

NOTICE**ENCLOSURE SIZE**

Enclosure size designations are used throughout this guide where procedures or components differ between drives based on size. Refer to *chapter 3.4 Enclosure Size Identification* and *chapter 3.5 Enclosure Size Definitions* in determining enclosure size.

11.2 D2h/D4h/D7h/D8h/J9 Disassembly and Assembly

11.2.1 General Information

This chapter contains instructions for disassembly and assembly of D2h/D4h drives. The instructions can be used for related drives and drive modules listed in *Table 11.2*.

Drive model	Description
D2h drive	Standard drive in an IP21/IP54 (UL type 1/12) enclosure
D4h drive	Similar to D2h, but IP20/Chassis drive with no enclosure
D7h drive	Similar to D2h drive, but with extended options cabinet
D8h drive	Similar to D2h drive, but with tall extended options cabinet
J9 drive	Similar to D2h, but regen terminals are standard, and no brake option is available
Parallel drive modules	Similar to D4h, but includes 2 or 4 drive modules in Db2/Db4 parallel drive systems
Enclosed drive module	Similar to D4h, but includes 1 drive module in D10h enclosed drive system

Table 11.2 Drives and Drive Modules Related to D2h Drive

11.2.2 Control Card and Control Card Mounting Plate

To remove or reinstall the control card mounting plate, use the following steps. Refer to *Illustration 11.1*.

Disassembly

1. Open the front panel door or remove the front cover, depending on the enclosure type.
2. Remove the LCP cradle. The LCP cradle can be removed by hand.
3. Remove any customer control wiring from the control card terminal blocks and option cards.
4. Remove the 4 screws (T20) from the corners of the control card mounting plate.
5. Unplug the ribbon cable connecting the control card and the power card.

Reassembly

Tighten fasteners according to *chapter 14.1 Fastener Torque Ratings*.

1. Position the control card mounting plate in the unit.
2. Secure 4 screws (T20), 1 in each corner of the control card mounting plate.
3. Reconnect any customer control wiring to the control card terminal blocks and option cards.
4. Replace the LCP cradle. The cradle can be replaced by hand.
5. Replace the front cover or door of the drive.

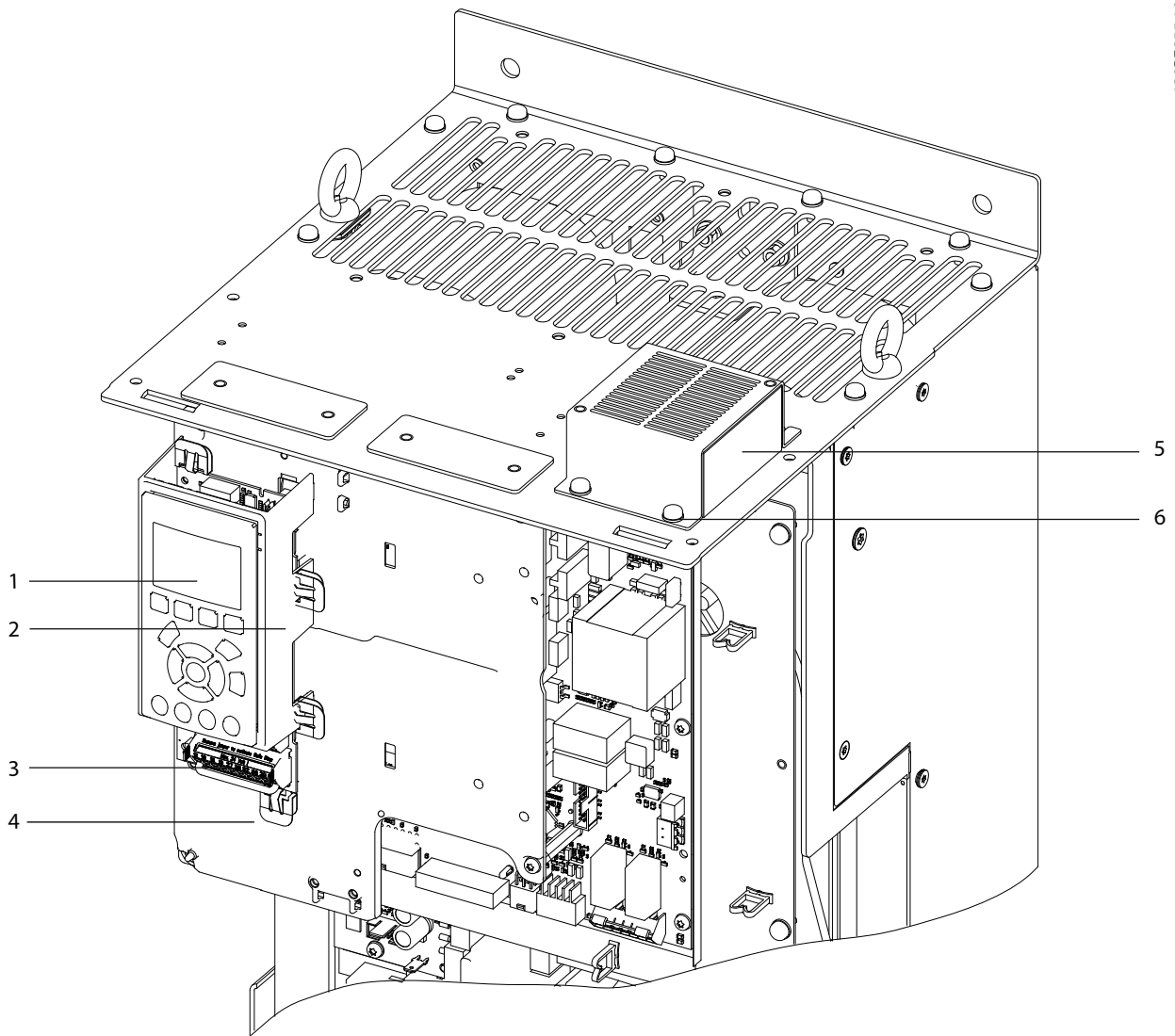

1	LCP	4	Control card mounting plate
2	LCP cradle	5	Top fan
3	Control terminals	6	Screw (T25)

Illustration 11.1 Control Card and Control Card Mounting Plate

11.2.3 Power Card Mounting Plate

The power card can remain attached when the power card mounting plate is removed from the drive. To remove the power card mounting plate, use the following steps. Refer to *Illustration 11.2*.

To remove the power card from the mounting plate, refer to *chapter 11.2.4 Power Card*.

NOTICE

FASTENER VARIATIONS

The IP21 (UL type 1) and IP54 (UL type 12) drives have different types and numbers of fasteners.

Disassembly

1. Remove the control card mounting plate. Refer to *chapter 11.2.2 Control Card and Control Card Mounting Plate*.
2. Unplug cables from the following power card connectors:

2a	MK101
2b	MK103
2c	MK106
2d	MK500
2e	MK501
2f	MK502
2g	MK902
3. Remove the 4 screws (T25), 1 from each corner of the mounting plate.
4. Remove the 1 screw (T25) from the top center of the mounting plate.
5. Remove the power card mounting plate from the unit.

NOTICE

PARTS REUSE

When installing the power card, ensure that the insulator sheet is installed behind the power card.

Reassembly

Reinstall in reverse order of this procedure. Tighten hardware according to *chapter 14.1 Fastener Torque Ratings*.

11.2.4 Power Card

To remove or reinstall the power card, use the following steps. Refer to *Illustration 11.2*.

NOTICE

PARTS REUSE

A current scaling card is not included with the replacement power card. Retain the current scaling card so it can be reinstalled on the new power card.

Disassembly

1. Remove the control card mounting plate. Refer to *chapter 11.2.2 Control Card and Control Card Mounting Plate*.
2. Unplug the following power card connectors:

2a	MK101
2b	MK103
2c	MK106
2d	MK500
2e	MK501
2f	MK502
2g	MK902
3. Remove 5 screws (T20) from the power card.
4. Remove 2 standoffs (8 mm) from the power card.
5. Remove the power card from 3 plastic standoffs, pinching the standoffs to compress them.
6. Remove the current scaling card from the power card, pinching the tip of the plastic standoff. To avoid bending the card, lift it parallel to the power card.
7. Remove the insulator sheet from the power card mounting plate.

Reassembly

Reinstall in reverse order of this procedure. Tighten hardware according to *chapter 14.1 Fastener Torque Ratings*.

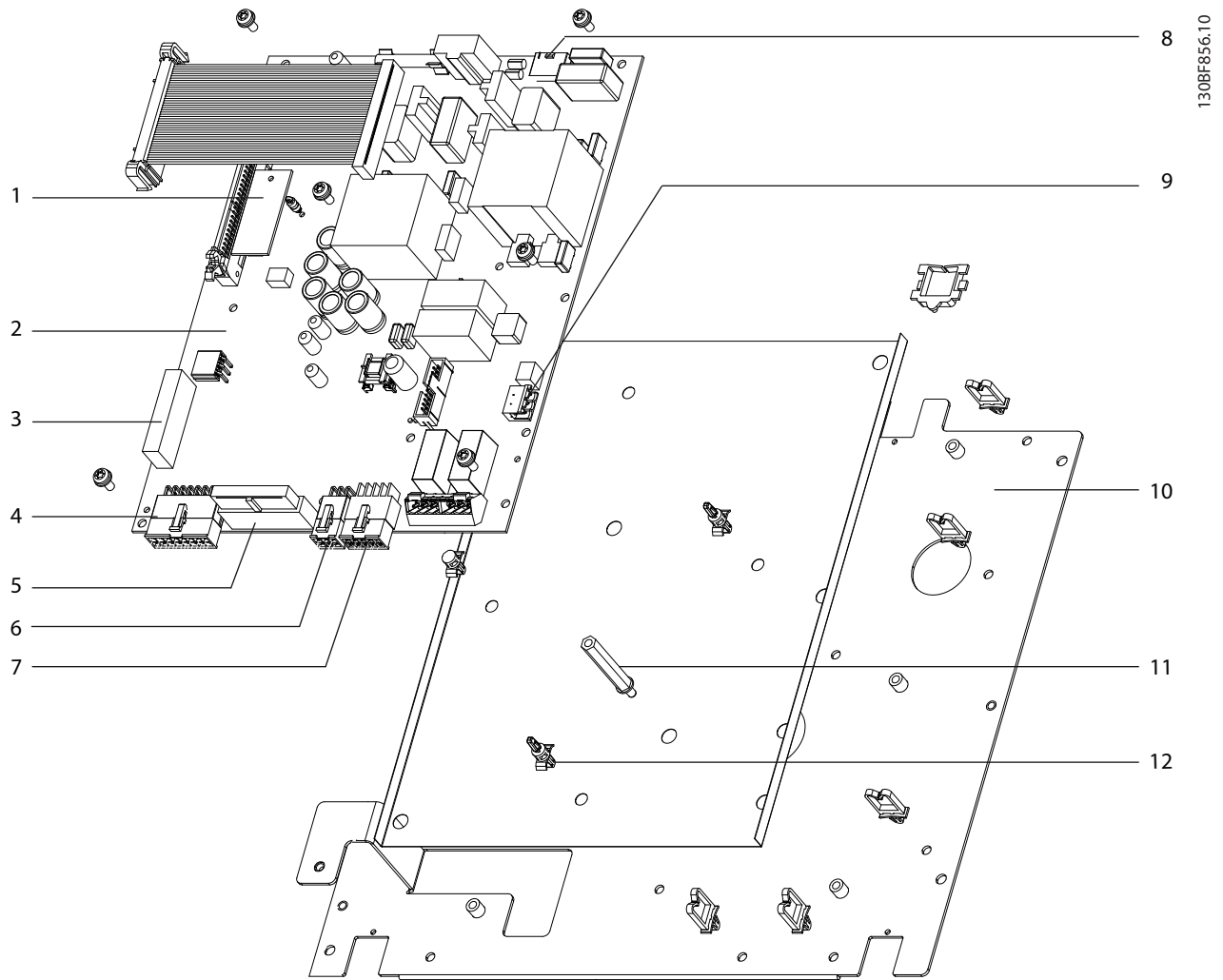

1	Current scaling card	7	MK501
2	Power card (PCA3)	8	MK902
3	MK104	9	MK106
4	MK101	10	Power card mounting plate
5	MK103	11	Standoff (8 mm)
6	MK502	12	Plastic standoff

Illustration 11.2 Power Card and Power Card Mounting Plate

11.2.5 AC Input Busbars

To remove the AC input busbars, use the following steps. The AC input busbars can look different when the drive includes extra input options, such as RFI filter or mains fuses. *Illustration 11.3* shows the AC input busbars configured to include mains fuses.

1. Remove the air baffle by removing 4 screws (T25) and 2 nuts (13 mm).
2. The next step differs based on the input options present in the drive. Select the appropriate procedure for the drive:
 - No options
 - Mains fuses only
 - RFI filter only
 - Mains fuses and RFI filter

No Options

1. Remove 3 nuts (13 mm), 1 from the top of each AC input busbar.
2. Remove 3 nuts (13 mm), 1 from the bottom of each AC input busbar.
3. Remove the busbars from the drive module.

AC fuses only

1. Remove AC fuses by removing 6 nuts (13 mm), 1 from each end of the 3 fuses.
2. Remove 3 nuts (13 mm), 1 from the top of each AC input busbar.
3. Remove the AC input busbars from the drive module.

RFI filter only

1. Remove 3 nuts (13 mm) at the top of the RFI filter, 1 per bus phase.
2. Remove 6 nuts (13 mm) at the bottom of the RFI filter, 2 per bus phase
3. Remove 4 thread-cutting screws (T20), which connect the RFI filter to the side channels of the drive module.
4. Unplug the RFI cable from the MK100 connector on the RFI printed circuit card.
5. Lift the RFI filter from the drive module.

AC fuses and RFI filter

1. Remove AC fuses by removing 6 nuts (13 mm), 1 from each end of the 3 fuses.
2. Remove 3 nuts (13 mm) from the top of the RFI filter, 1 per bus phase.
3. Remove 4 thread-cutting screws (T20), which connect the RFI filter to the side channels of the drive module.
4. Unplug the RFI cable from the MK100 connector on the RFI printed circuit card.
5. Lift the RFI filter from the drive module.

Reassembly

Reinstall in reverse order of these procedures. Tighten fasteners according to *chapter 14.1 Fastener Torque Ratings*.

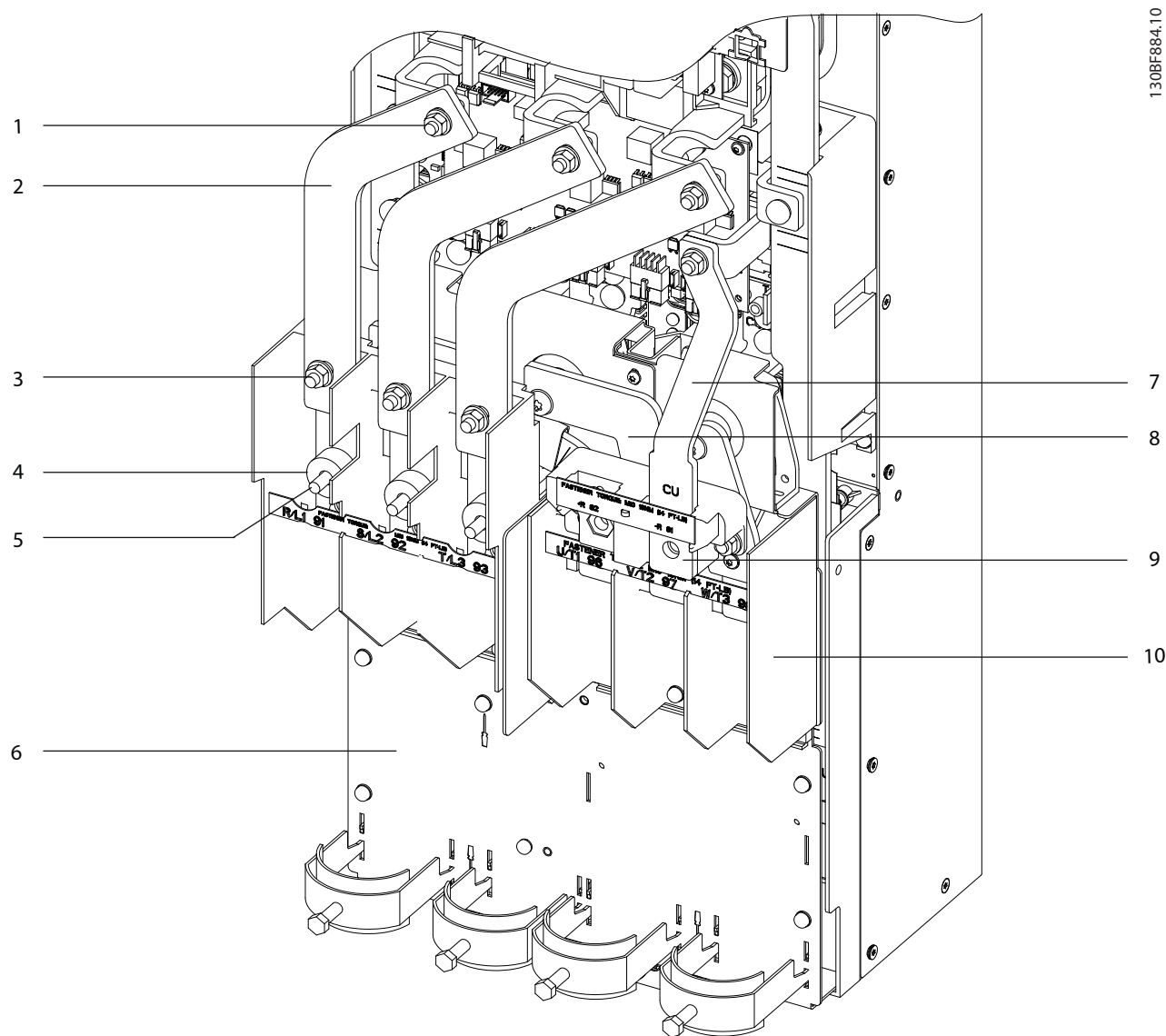

130BF884.10

1	Top nut (13 mm)	6	Power terminal mounting plate
2	AC input busbar	7	Brake busbar (optional)
3	Bottom nut (13 mm)	8	U motor busbar
4	Fuse spacer	9	Brake terminal (optional)
5	Mains input terminal	10	Motor terminal block

Illustration 11.3 AC Input Busbars and Power Terminals

11.2.6 Mains Input Terminal Block

To remove or reinstall the mains input terminal block, use the following steps. See *Illustration 11.3* and *Illustration 11.4*.

Disassembly

1. Disconnect the customer input power wiring.
2. Remove the AC input busbars. Refer to *chapter 11.2.5 AC Input Busbars*.
3. Remove 2 screws (T25) at the bottom of the mains input terminal block.
4. Release current sensor wiring from the cable retaining clips (not shown).
5. Place the R/S/T terminal label above the terminal connections. Slide the mains input terminal block downward to disengage it from the 2 metal retaining clips holding it in place.

Reassembly

Tighten fasteners according to *chapter 14.1 Fastener Torque Ratings*.

1. Position the mains input terminal block on the power terminal mounting plate and slide it upward under 2 metal retaining clips.
2. Fasten 2 screws (T25) at the bottom of the mains input terminal block.
3. Route the current sensor wiring through the cable retaining clips.
4. Place the R/S/T terminal label above the terminal connections.
5. Replace the AC input busbars. Refer to *chapter 11.2.5 AC Input Busbars*.
6. Reconnect customer input wiring.

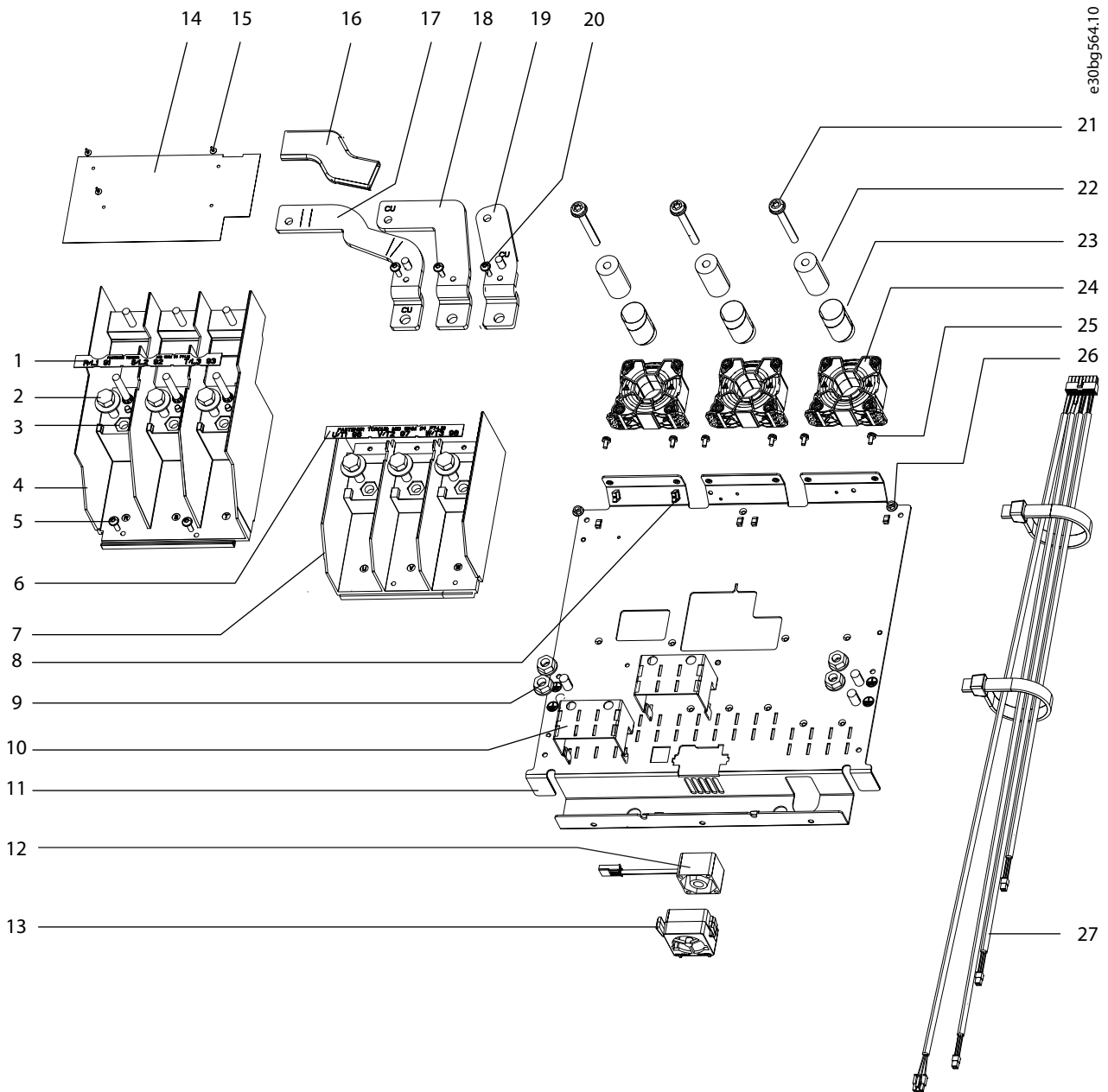

e30bg564.10

11

1	R/S/T terminal label	10	Cable clamp adapter	19	Motor busbar, W
2	Machine screw	11	Power terminal mounting plate	20	Torx screw
3	Nut	12	Mixing fan	21	Screw
4	Mains input terminal block	13	Mixing fan housing	22	Cylinder busbar
5	Machine screw	14	EMC shield	23	Nomex tube
6	U/V/W terminal label	15	Plastic mounting button	24	Current sensor
7	Motor terminal block	16	Busbar insulator sleeve	25	Thread-forming screw
8	Cable retaining clip	17	Motor busbar, U	26	Nut
9	Nut with captive washer	18	Motor busbar, V	27	Current sensor cables

Illustration 11.4 Exploded View of Terminal Blocks and Current Sensors

11.2.7 EMC Shield

To remove or reinstall the EMC shield, use the following steps. See *Illustration 11.4*.

Disassembly

1. Remove 1 screw (T20) from the EMC shield.
2. Remove the EMC shield from the drive.

Reassembly

Tighten fasteners according to *chapter 14.1 Fastener Torque Ratings*.

1. Position the EMC shield in the drive.
2. Secure 1 screw (T20) in the EMC shield.

11.2.8 Brake Terminal Block (Optional)

Drives can include an optional brake. To remove or reinstall the optional brake terminal block, use the following steps. Refer to *Illustration 11.3*.

Disassembly

1. Disconnect the brake wiring.
2. To remove the R(+) terminal:
 - 2a Remove 1 thread-forming screw (T25) from the terminal block.
 - 2b Remove 1 screw (T40).
3. To remove the R(-) terminal:
 - 3a Remove 1 thread-forming screw (T25) from the terminal block.
 - 3b Remove 1 nut (13 mm).
4. Remove the brake terminal block by removing 2 nuts (13 mm).

Reassembly

Tighten fasteners according to *chapter 14.1 Fastener Torque Ratings*.

1. Position the brake terminal block in the drive and secure 2 nuts (13 mm).
2. To attach the R(-) terminal:
 - 2a Fasten 1 thread-forming screw (T25) in the terminal block.
 - 2b Fasten 1 nut (13 mm).
3. To attach the R(+) terminal:
 - 3a Fasten 1 thread-forming screw (T25) in the terminal block.
 - 3b Secure 1 screw (T40).
4. Reconnect the brake wiring.

11.2.9 Motor Terminal Block

To remove or reinstall the motor terminal block, use the following steps. Refer to *Illustration 11.3* and *Illustration 11.4*.

Disassembly

1. Remove the mains input terminal block. Refer to *chapter 11.2.6 Mains Input Terminal Block*.
2. Remove the optional brake terminal, if present. Refer to *chapter 11.2.8 Brake Terminal Block (Optional)*.
3. Disconnect wiring to the motor, and remove the U/V/W terminal label.
4. Remove the EMC shield:
 - 4a Remove 1 screw (T25).
 - 4b Lift the EMC shield from the drive.
5. Remove the U motor busbar:
 - 5a Remove 1 thread-forming screw (T25) from the middle of the U busbar.
 - 5b Unfasten 1 bolt (T40) from the U busbar.
6. Remove the V motor busbar:
 - 6a Remove 1 thread-forming screw (T25) from the middle of the V busbar.
 - 6b Unfasten 1 bolt (T40) from the V busbar.
7. Remove the W motor busbar:
 - 7a Remove 1 thread-forming screw (T25) from the middle of the W busbar.
 - 7b Unfasten 1 bolt (T40) from the W busbar.
8. Remove 3 current sensor cylinder busbars.
9. Remove 2 screws (T25) from the bottom of the motor terminal block.
10. Remove the motor terminal block by sliding it down to disengage it from the 2 metal retaining clips.

Reassembly

Tighten fasteners according to *chapter 14.1 Fastener Torque Ratings*.

1. Position the output terminal block by sliding it upward under the 2 metal retaining clips on the power terminal mounting plate.
2. Fasten 2 machine screws (T25) at the bottom of the terminal block.
3. Position the 3 Nomex tubes, 1 in the middle of each current sensor.
4. Insert 3 cylinder busbars, 1 inside each Nomex tube.
5. Replace the U motor busbar:
 - 5a Slide the insulator sleeve over the U busbar.
 - 5b Fasten 1 screw (T30) in the current sensor end of the busbar.
 - 5c Fasten 1 thread-forming screw (T25) in the middle of the busbar.
6. Replace the V motor busbar:
 - 6a Fasten 1 screw (T30) in the current sensor end of the busbar.
 - 6b Fasten 1 thread-forming screw (T25) in the middle of the busbar.
7. Replace the W motor busbar:
 - 7a Fasten 1 screw (T30) in the current sensor end of the busbar.
 - 7b Fasten 1 thread-forming screw (T25) in the middle of the busbar.
8. Position the EMC shield between the mains input terminal block and motor terminal block and secure with 1 screw (T25).
9. Replace the optional brake terminal, if present. Refer to *chapter 11.2.8 Brake Terminal Block (Optional)*.
10. Replace the mains input terminal block. Refer to *chapter 11.2.6 Mains Input Terminal Block*.
11. Reconnect wiring to the motor terminals, and replace the U/V/W terminal label.

11.2.10 Mixing Fan

The mixing fan snaps into a slot in the power terminal mounting plate. To remove or reinstall the mixing fan, use the following steps. See *Illustration 11.5*.

Disassembly

1. Place the end of a screwdriver under each of the mixing fan release tabs. Press in and lift to free the fan and housing from the power terminal mounting plate.
2. Unplug the mixing fan cable connector. Tape the free end of the fan cable to the mounting plate so that it does not fall back into the drive.
3. Remove the mixing fan from the fan housing.

Reassembly

1. Connect the fan cable to the mixing fan cable connector.
2. Position the mixing fan in the fan housing.
3. Position the fan and housing in the fan slot on the power terminal mounting plate.
4. Press the mixing fan into the slot until the release tabs snap into place.

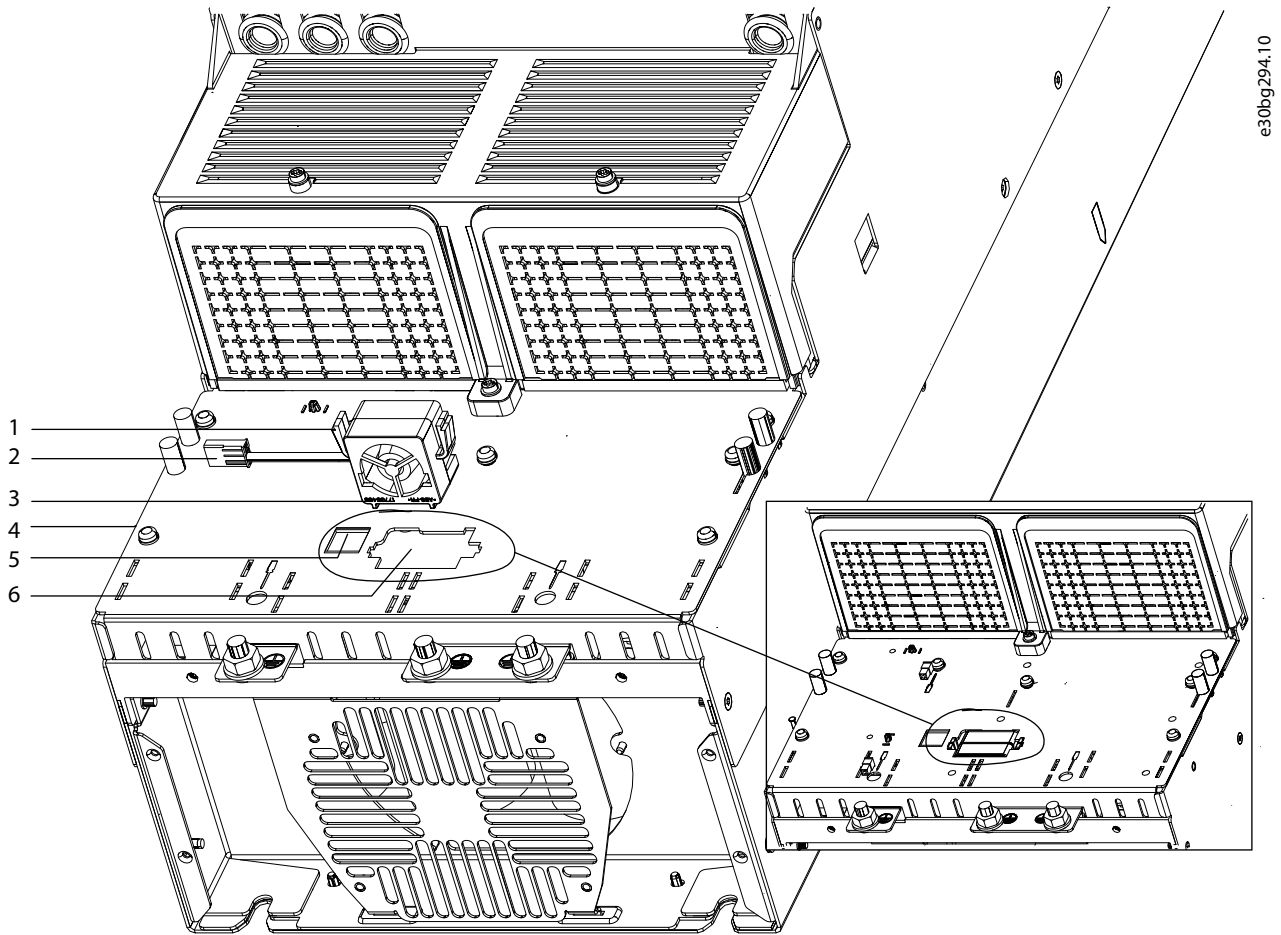

e30bg294.10

1	Mixing fan release tab	4	Power terminal mounting plate
2	Cable connector	5	Cable access hole
3	Mixing fan	6	Mixing fan slot

Illustration 11.5 Mixing Fan

11.2.11 Power Terminal Mounting Plate

To remove or reinstall the power terminal mounting plate, use the following steps. Refer to *Illustration 11.4* and *Illustration 11.6*.

Disassembly

1. Remove the motor terminal block. Refer to *chapter 11.2.9 Motor Terminal Block*.
2. Remove 5 thread-forming screws (T25) from the power terminal mounting plate.
3. Remove 3 nuts (8 mm) from the bottom of the power terminal mounting plate.
4. Remove the power terminal mounting plate from the unit.

Reassembly

Tighten fasteners according to *chapter 14.1 Fastener Torque Ratings*.

1. Position the power terminal mounting plate in the unit.
2. Secure 5 thread-forming screws (T25) in the power terminal mounting plate.
3. Fasten 3 nuts (8 mm) at the bottom of the plate.
4. Replace the motor terminal block. Refer to *chapter 11.2.9 Motor Terminal Block*.

11.2.12 Current Sensors

NOTICE

PARTS VARIATIONS

Due to differences in manufacturer, some current sensors look different than the sensors shown in *Illustration 11.6*. LEM is the manufacturer of current sensors used since the first quarter of 2016. Previously, Honeywell manufactured the current sensors.

To remove or reinstall the current sensors, use the following steps. See *Illustration 11.6*.

Disassembly

1. Remove the power terminal mounting plate. Refer to *chapter 11.2.11 Power Terminal Mounting Plate*.
2. Disconnect the current sensor cable from the cable connector on each of the 3 current sensors.
3. Remove 6 screws (T20), 2 from each of the 3 current sensors.
4. Remove the current sensors from the unit.

Reassembly

Tighten fasteners according to *chapter 14.1 Fastener Torque Ratings*.

1. Position 3 current sensors on top of the power terminal mounting plate so that the cable connectors face the back of the drive. Ensure that the airflow arrows on the sensors point toward the front of the drive.
2. Secure 6 thread-forming screws (T20), 2 in the base of each current sensor. Torque to 2.0 Nm (17.7 in-lb).
3. Connect the current sensors cables to the current sensors, 1 cable to each current sensor.
4. Route the cables through the cable guides.
5. Replace the power terminal mounting plate. Refer to *chapter 11.2.11 Power Terminal Mounting Plate*.

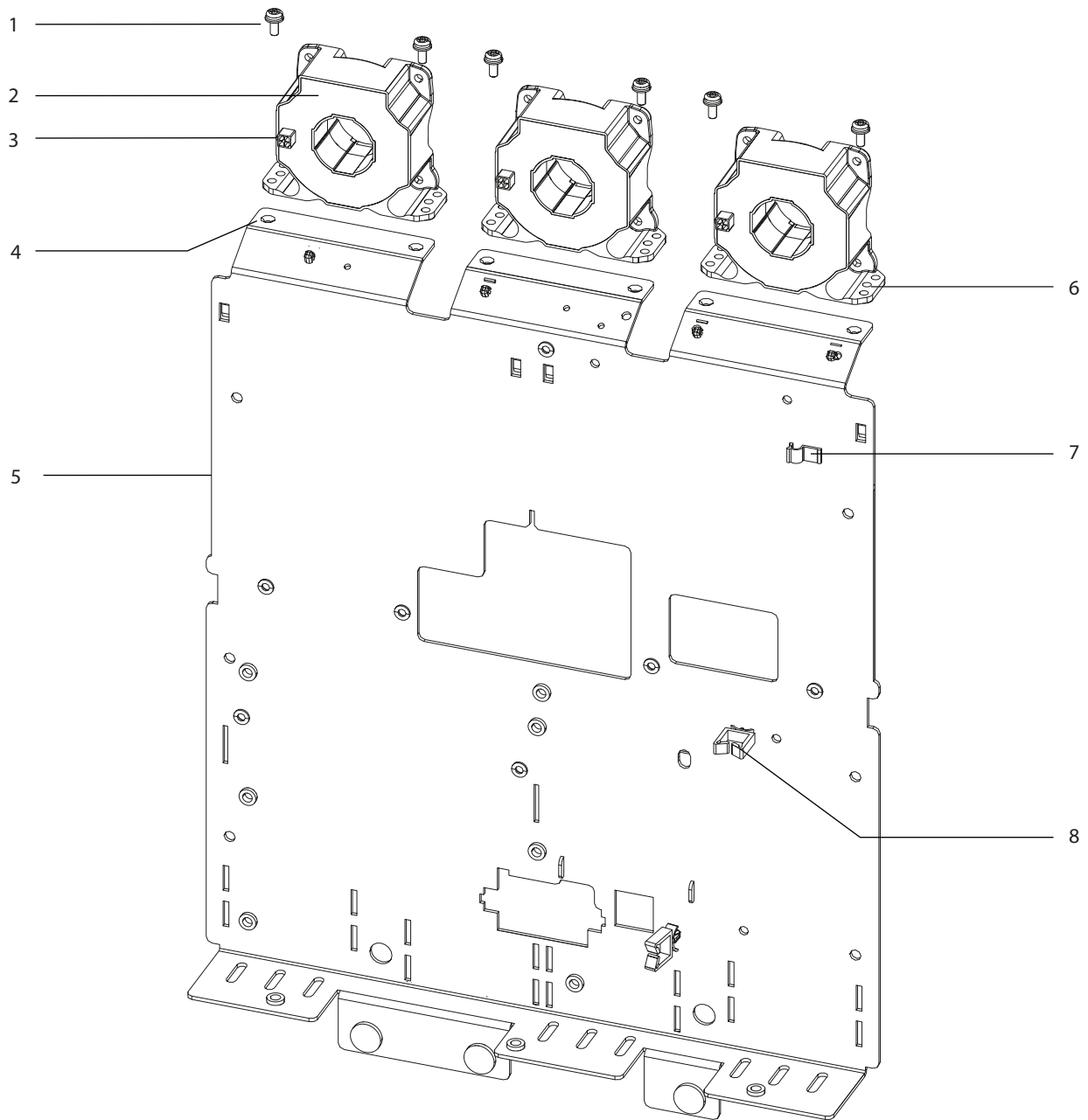

11

1	Thread-forming screw (T20)	5	Power terminal mounting plate
2	Current sensor	6	Mounting hole
3	Current sensor cable connector	7	Wire guide
4	Mounting hole	8	Cable clip

Illustration 11.6 D2h Power Terminal Mounting Plate and Current Sensors

11.2.13 Balance/High Frequency Card

To remove or reinstall the balance/high frequency card for 240/400 V AC or 690 V AC drives, use the following steps. Refer to *Illustration 11.7*.

Disassembly in 240/400 V AC units

1. Remove the power terminal mounting plate. Refer to *chapter 11.2.11 Power Terminal Mounting Plate*.
2. Unplug the cable from the MK100 connector on the balance/high frequency card.
3. Remove 1 standoff (8 mm) from the corner of the card.
4. Remove 3 nuts (8 mm) from the card. Two of the nuts also hold in place the DC(+) and DC(-) wires.
5. Remove the balance/high frequency card and insulator sheet from the drive.

Reassembly in 240/400 V AC units

Tighten hardware according to *chapter 14.1 Fastener Torque Ratings*.

1. Place the insulator sheet and balance/high frequency card in the drive.
2. Fasten 3 nuts (8 mm) in the card. Two of the nuts also hold in place the DC(+) and DC(-) wires.
3. Fasten 1 standoff (8 mm) in the corner of the card.
4. Connect the cable to the MK100 connector on the balance/high frequency card.
5. Replace the power terminal mounting plate. Refer to *chapter 11.2.11 Power Terminal Mounting Plate*.

Disassembly in 690 V AC units

1. Remove the power terminal mounting plate. Refer to *chapter 11.2.11 Power Terminal Mounting Plate*.
2. Unplug the cable from the MK100 connector on the balance/high frequency card.
3. Remove 1 standoff (8 mm) from the corner of the card.
4. Remove 3 nuts (8 mm) and 1 screw (T20) from the card. One of the nuts and the screw also hold in place the DC(+) and DC(-) wires.
5. Remove the balance/high frequency card and insulator sheet from the unit.

Reassembly in 690 V AC units

Tighten hardware according to *chapter 14.1 Fastener Torque Ratings*.

1. Place the insulator sheet and balance/high frequency card in the unit.
2. Fasten 3 nuts (8 mm) and 1 screw (T20) in the card. One of the nuts and the screw also hold in place the DC(+) and DC(-) wires.
3. Fasten 1 standoff (8 mm) in the corner of the card.
4. Connect the cable to the MK100 connector on the balance/high frequency card.
5. Replace the power terminal mounting plate. Refer to *chapter 11.2.11 Power Terminal Mounting Plate*.

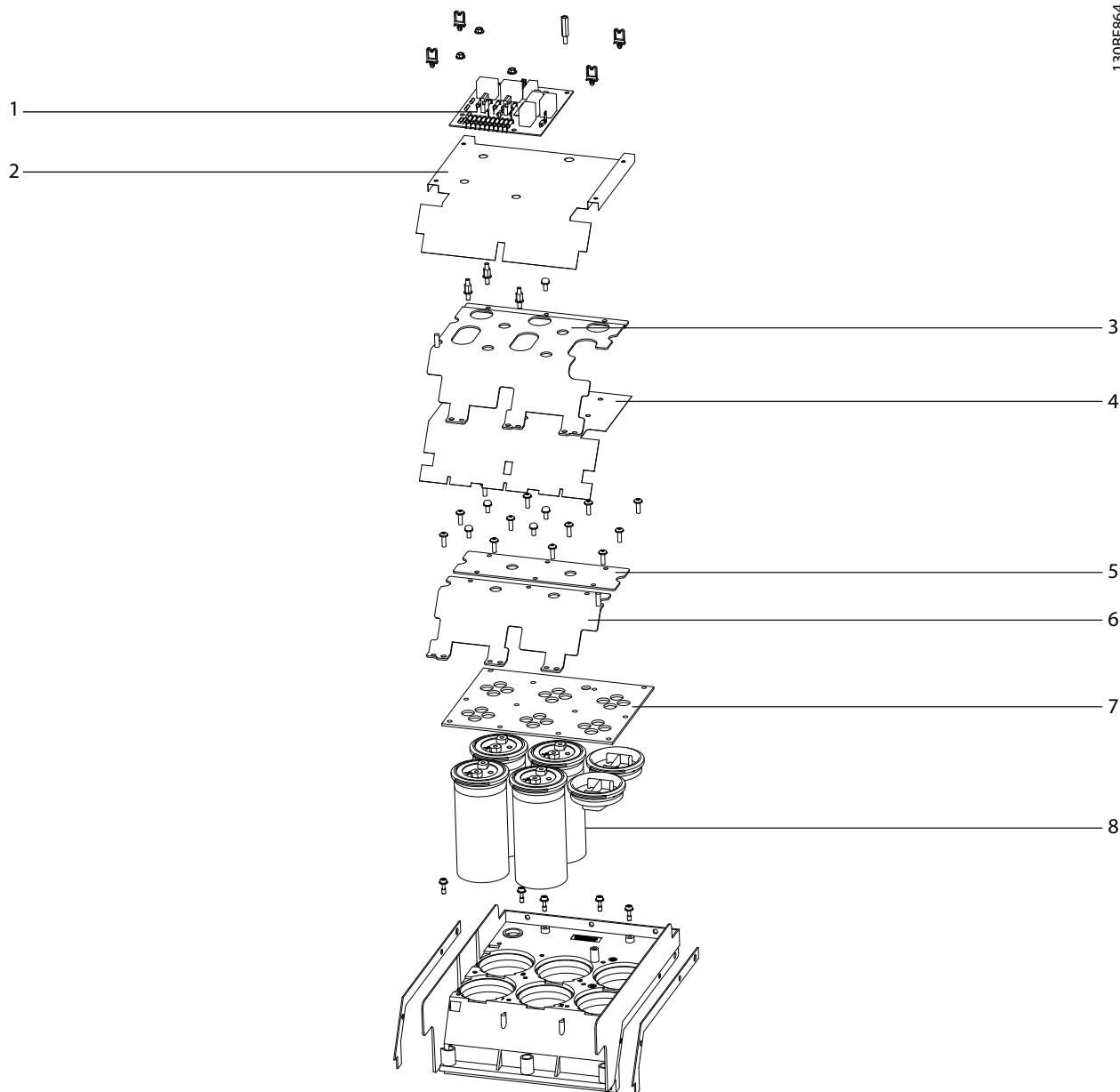

11

1	Balance/high frequency card	5	DC center capacitor plate
2	Capacitor bank cover	6	DC(+) capacitor plate
3	DC(-) capacitor plate	7	Capacitor locking panel
4	Insulator sheet	8	DC capacitor

Illustration 11.7 Balance/High Frequency Card and DC Capacitor Bank (240/400 V unit shown, 690 V unit is similar.)

11.2.14 Gate Drive Card

To remove or replace the gate drive card, use the following steps. Refer to *Illustration 11.8*.

Disassembly

1. Remove the AC input busbars or RFI option (not shown). Refer to *chapter 11.2.5 AC Input Busbars*.
2. Unplug the cables from the following gate drive card connectors:
 - 2a MK100
 - 2b MK102
 - 2c MK201, if brake option is present
 - 2d MK501
 - 2e MK601
 - 2f MK701
3. Remove 6 thread-forming screws (T20) from the gate drive card. Remove the card from the unit.

Reassembly

Tighten hardware according to *chapter 14.1 Fastener Torque Ratings*.

1. Position the gate drive card in the unit.
2. Fasten 6 thread-forming screws (T20) in the gate drive card.
3. Plug the cables into the following gate drive card connectors:
 - 3a MK100
 - 3b MK102
 - 3c MK201, if brake option is present
 - 3d MK501
 - 3e MK601
 - 3f MK701
4. Replace the AC input busbars or RFI option (not shown). Refer to *chapter 11.2.5 AC Input Busbars*.

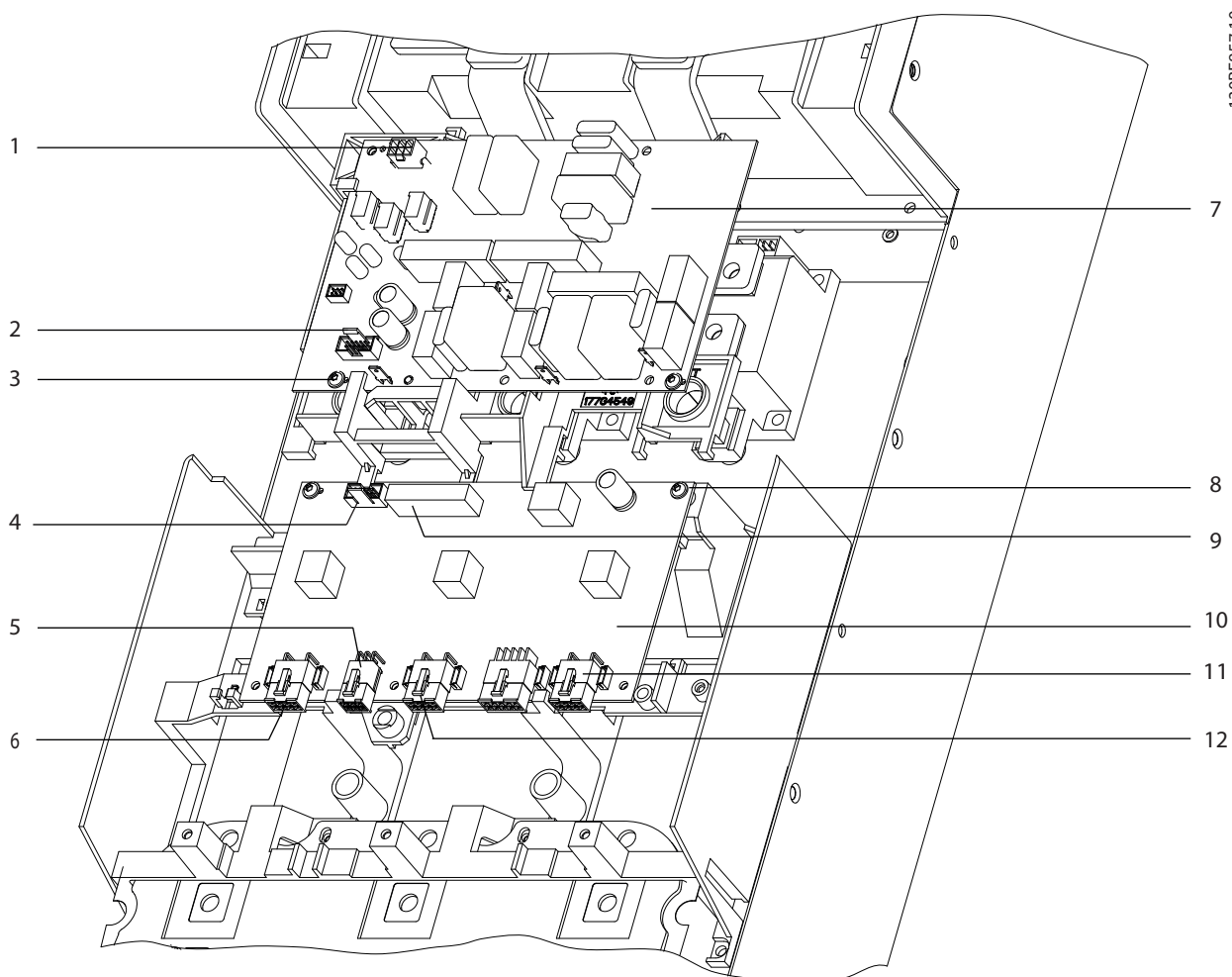

11

1	MK1802	7	Inrush card
2	MK1800	8	Screw (T20)
3	Screw (T20)	9	MK101
4	MK102	10	Gate drive card
5	MK100	11	MK701
6	MK501	12	MK601

Illustration 11.8 Gate Drive Card and Inrush Card

11.2.15 Inrush Card

To remove or replace the inrush card, use the following steps. Refer to *Illustration 11.8*.

Disassembly

1. Remove the power card mounting plate. Refer to *chapter 11.2.3 Power Card Mounting Plate*.
2. Unplug the cable from the inrush card connector MK1802.
3. Remove 2 thread-forming screws (T20).
4. Remove 5 screws (T20) from the inrush card.
5. Remove the inrush card from the unit.

Reassembly

Tighten hardware according to *chapter 14.1 Fastener Torque Ratings*.

1. Position the inrush card in the drive.
2. Secure 5 screws (T20) in the inrush card.
3. Secure 2 thread-forming screws (T20).
4. Connect the cable to the inrush card connector MK1802.
5. Replace the power card mounting plate. Refer to *chapter 11.2.3 Power Card Mounting Plate*.

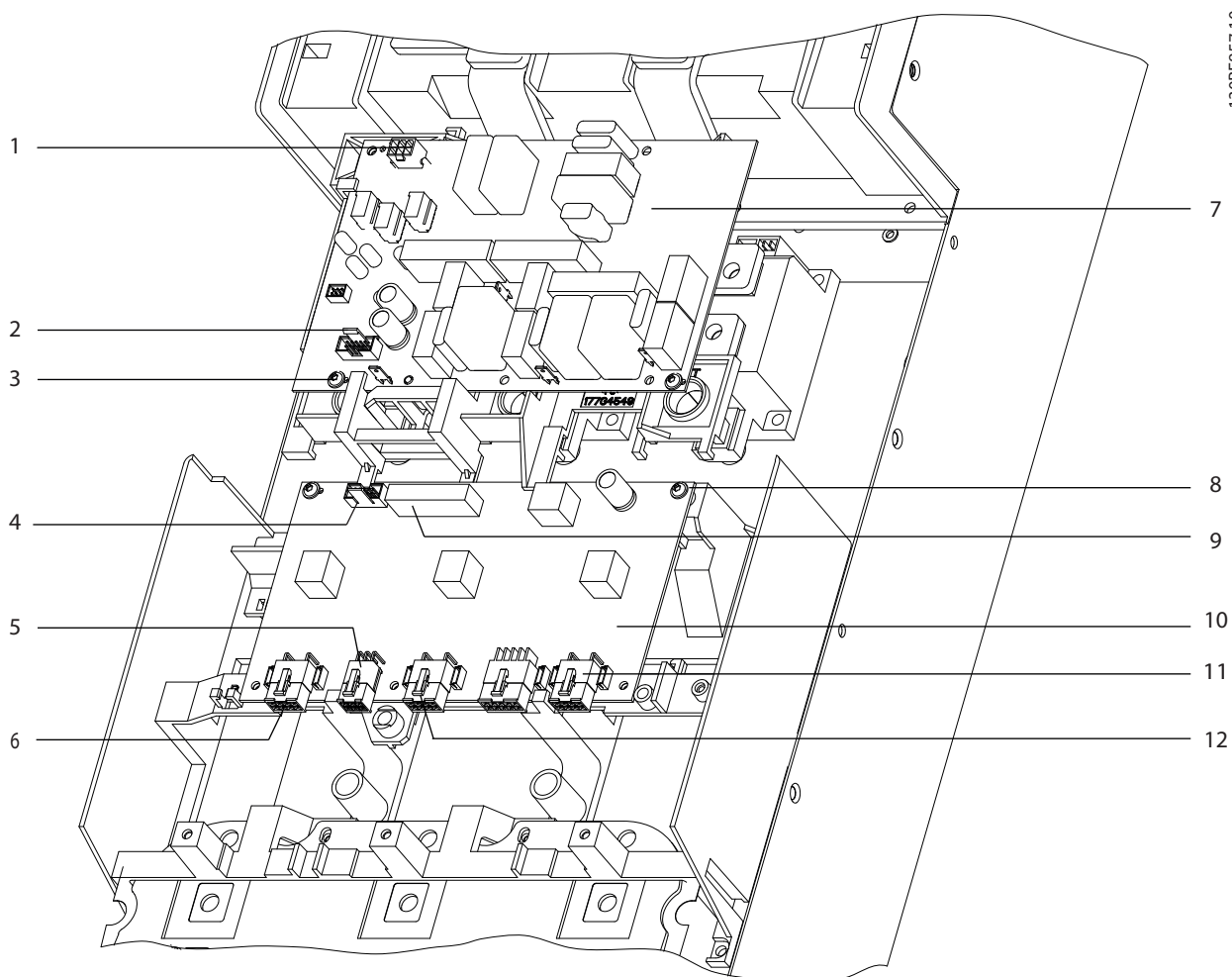

11

1	MK1802	7	Inrush card
2	MK1800	8	Screw (T20)
3	Screw (T20)	9	MK101
4	MK102	10	Gate drive card
5	MK100	11	MK701
6	MK501	12	MK601

Illustration 11.9 Inrush Card and Gate Drive Card

11.2.16 SCR Input Busbars

To remove or reinstall the SCR input busbars, use the following steps. Refer to *Illustration 11.10*.

Disassembly

1. Remove the inrush card. Refer to *chapter 11.2.15 Inrush Card*.
2. Remove 2 screws (T20) from the middle of the inrush card support bracket.
3. Remove 2 standoffs (16 mm) from the inrush card support bracket.
4. Remove 3 standoffs (19 mm) connecting the busbars to the SCR modules, 1 for each SCR input busbar.
5. Remove the SCR input busbars from the unit.

NOTICE

PARTS ALIGNMENT

To align all components, hand-fasten the hardware and then position the inrush card support bracket before tightening.

Reassembly

Tighten hardware according to *chapter 14.1 Fastener Torque Ratings*.

1. Position the SCR input busbars in the unit.
2. Fasten 3 standoffs (19 mm) connecting the busbars to the SCR modules, 1 for each SCR input busbar.
3. Fasten 2 standoffs (16 mm) in the inrush card support bracket.
4. Secure 2 screws (T20) in the middle of the inrush card support bracket.
5. Replace the inrush card. Refer to *chapter 11.2.15 Inrush Card*.

11.2.17 SCRs

To remove or reinstall the SCRs, use the following steps. Refer to *Illustration 11.10*.

Disassembly

1. Remove the SCR input busbars. Refer to *chapter 11.2.16 SCR Input Busbars*.
2. Remove the DC(+) busbar by removing 3 screws (T50), 1 from each SCR module.
3. Remove the DC(-) busbar by removing 1 screw (T30) and 3 screws (T50), 1 from each SCR module.
4. Disconnect the gate leads, 1 from each SCR module.
5. Remove 1 screw (T30) from each of the 4 corners of each SCR module.

Reassembly

For reassembly, use the SCR spare part instructions that come with the parts kit. Tighten hardware according to *chapter 14.1 Fastener Torque Ratings*.

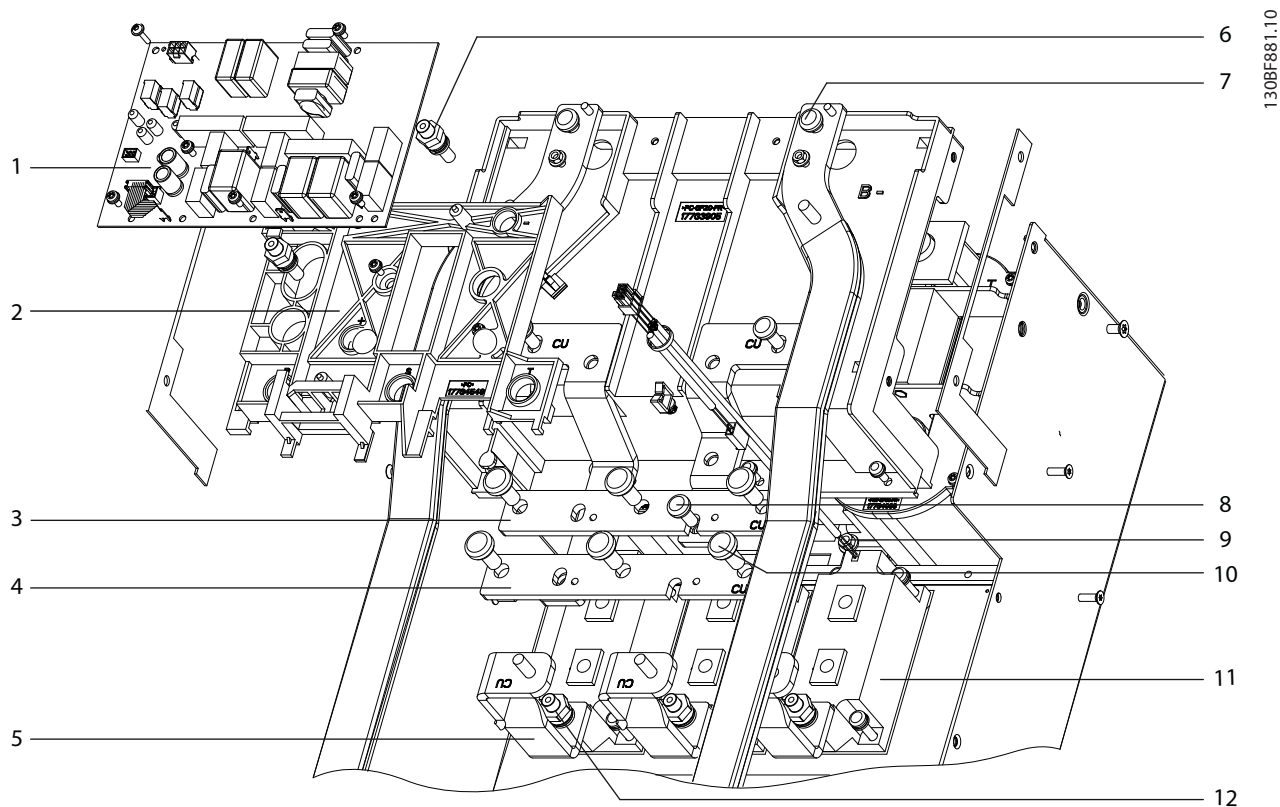

130BF881.10

1	Inrush card	7	Screw (T40)
2	Inrush support bracket	8	Screw (T30)
3	DC(-) busbar	9	Gate lead
4	DC(+) busbar	10	Screw (T50)
5	SCR input busbar	11	SCR
6	Standoff (16 mm)	12	Standoff (19 mm)

Illustration 11.10 SCRs and SCR Input Busbars

11.2.18 DC Bus Rails

To remove or reinstall the DC bus rails with brake option, use the following steps. Refer to *Illustration 11.11*.

11.2.18.1 Without Optional Brake

Disassembly

1. Remove the power card mounting plate. Refer to *chapter 11.2.3 Power Card Mounting Plate*.
2. Remove the power terminal mounting plate. Refer to *chapter 11.2.11 Power Terminal Mounting Plate*.
3. Remove the 2 screws (T40) at the top end of the DC bus rails, 1 per bus rail.
4. From the lower end of the DC bus rails, remove 4 nuts (10 mm), 2 per bus rail.

Reassembly

Tighten hardware according to *chapter 14.1 Fastener Torque Ratings*.

1. Secure 2 screws (T40) at the top end of the DC bus rails, 1 per bus rail.
2. Fasten 4 nuts (10 mm) at the lower end of the DC bus rails, 2 per bus rail.
3. Replace the power terminal mounting plate. Refer to *chapter 11.2.11 Power Terminal Mounting Plate*.
4. Replace the power card mounting plate. Refer to *chapter 11.2.3 Power Card Mounting Plate*.

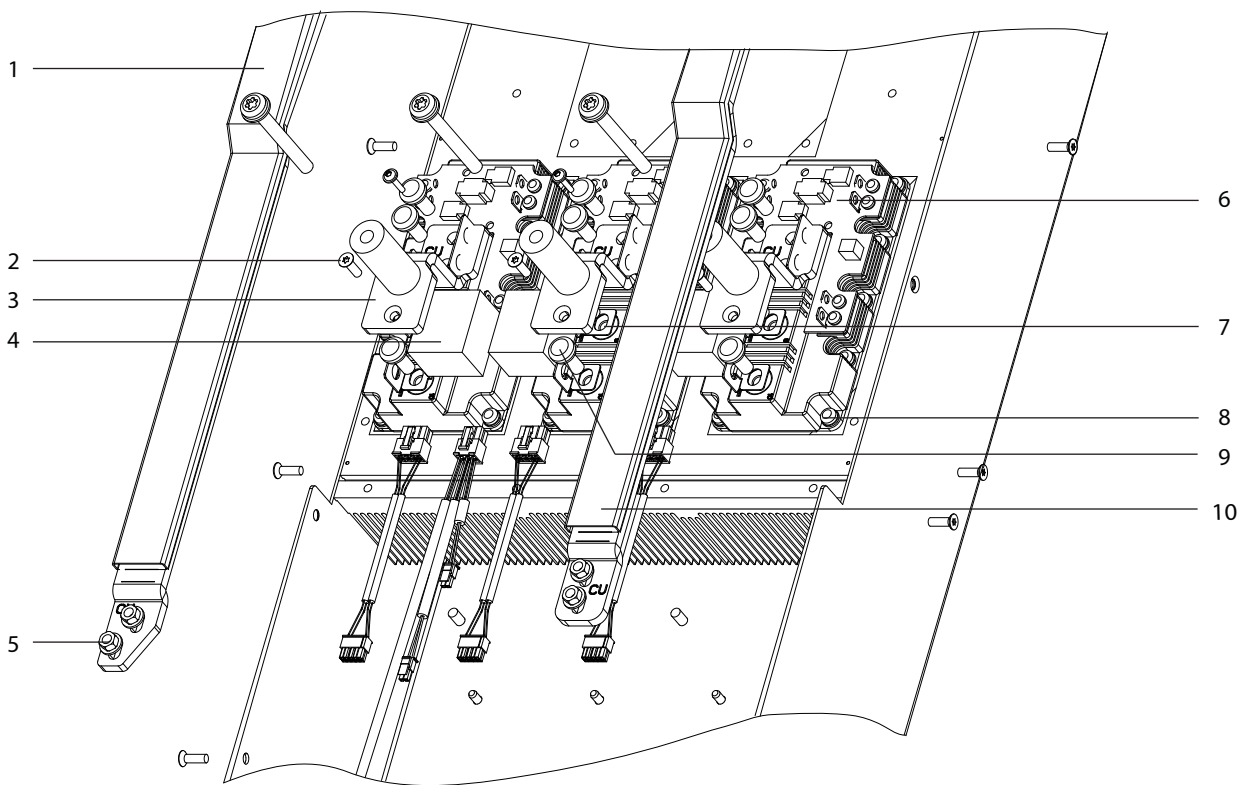

1	DC(+) bus rail	6	IGBT module
2	Screw (T20)	7	IGBT output busbar
3	IGBT output busbar	8	Screw (T40)
4	Snubber capacitor	9	Screw (T25)
5	Nut (8 mm)	10	DC(-) bus rail

Illustration 11.11 DC Bus Rails without Brake Option

11.2.18.2 With Optional Brake

To remove or reinstall the DC bus rails with optional brake, use the following steps. Refer to *Illustration 11.12*.

Disassembly

1. Remove the power card mounting plate. Refer to *chapter 11.2.3 Power Card Mounting Plate*.
2. Remove the power terminal mounting plate. Refer to *chapter 11.2.11 Power Terminal Mounting Plate*.
3. Remove 2 screws (T40) at the top end of the DC bus rails, 1 per bus rail.
4. Remove 4 nuts (10 mm) from the lower end of the DC bus rails, 2 per bus rail.
5. Remove 1 nut (13 mm) from the DC(+) bus rail, near the center.
6. Remove 1 screw (T40) from the DC(-) bus rail, near the center.
7. Remove the gate drive card. Refer to *chapter 11.2.14 Gate Drive Card*.

Reassembly

Tighten hardware according to *chapter 14.1 Fastener Torque Ratings*.

1. Replace the gate drive card. Refer to *chapter 11.2.14 Gate Drive Card*.
2. Fasten 1 screw (T40) in the DC(-) bus rail, near the center.
3. Fasten 1 nut (13 mm) in the DC(+) bus rail, near the center.
4. Secure 2 screws (T40) in the top end of the DC bus rails, 1 per bus rail.
5. Secure 4 nuts (10 mm) in the lower end of the DC bus rails, 2 per bus rail.
6. Replace the power terminal mounting plate. Refer to *chapter 11.2.11 Power Terminal Mounting Plate*.
7. Replace the power card mounting plate. Refer to *chapter 11.2.3 Power Card Mounting Plate*.

130BF853.10

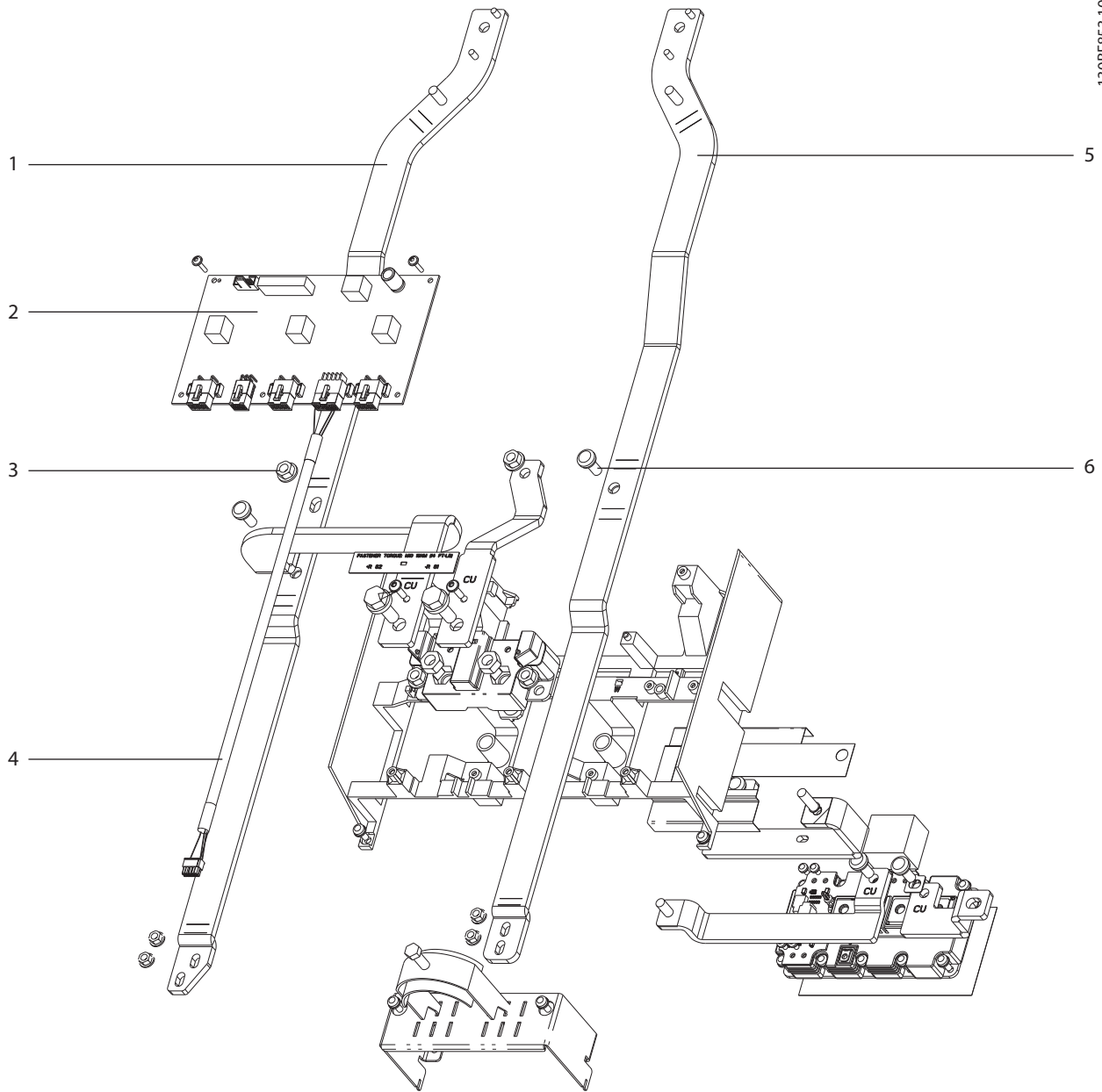

11

1	DC(+) bus rail	4	IGBT cable
2	Gate drive card	5	DC(-) bus rail
3	Nut (13 mm)	6	Screw (T40)

Illustration 11.12 DC Bus Rails with Brake Option

11.2.19 IGBTs

To remove or reinstall the IGBT modules, use the following steps for 400 V AC and 690 V AC units. Refer to *Illustration 11.13*.

Disassembly in 400 V AC units

1. Remove the gate drive card. Refer to *chapter 11.2.14 Gate Drive Card*.
2. Remove the balance/high frequency card. Refer to *chapter 11.2.13 Balance/High Frequency Card*.
3. Remove the DC bus rails. Refer to *chapter 11.2.18 DC Bus Rails*.
4. Remove the insulator sheet from the capacitor bank.
5. Remove 1 thread-forming screw (T20) from each IGBT output busbar.
6. Remove 2 screws (T40) connecting each IGBT output busbar to the IGBT module, and remove the busbars.
7. Remove the IGBT temperature cable by disconnecting the cable from each IGBT module.
8. Remove the gate leads, 1 from each IGBT.
9. Remove 2 screws (T40) from each snubber capacitor. Remove the snubber capacitors.
10. Remove the DC(+) plate by removing:
 - 10a 1 standoff (8 mm) connecting the plate to the positive terminal of capacitor 3.
 - 10b Screws (T25) from the positive terminals of capacitors 1, 2, 4, 9, and 12. Number of screws varies with drive size.
11. Remove the insulator sheet between the DC(+) plate and the DC(-) plate.
12. Remove the DC(-) plate by removing:
 - 12a 1 standoff (8 mm) connecting the plate to the negative terminal of capacitor 6.
 - 12b Screws (T25) connecting the plate to the negative terminals of capacitors 5, 7, 8, 10, and 11. Number of screws varies with drive size.
13. Remove the plastic IGBT support (not shown) by removing 7 screws (T25).
14. Remove the IGBTs by removing 10 screws (T25) from each IGBT module.

Disassembly in 690 V AC units

1. Remove the gate drive card. Refer to *chapter 11.2.14 Gate Drive Card*.
2. Remove the balance/high frequency card. Refer to *chapter 11.2.13 Balance/High Frequency Card*.
3. Remove the DC bus rails. Refer to *chapter 11.2.18 DC Bus Rails*.
4. Remove the insulator sheet from the capacitor bank.
5. Remove 1 thread-forming screw (T20) from each IGBT output busbar.
6. Remove the IGBT output busbar by removing 2 screws (T40) connecting the busbar to the IGBT module.
7. Remove the IGBT temperature cable by disconnecting the cable from each IGBT module.
8. Remove the gate leads, 1 from each IGBT.
9. Remove 2 screws (T40) from each snubber capacitor. Remove the snubber capacitors.
10. Remove the DC(+) plate by removing:
 - 10a 2 thread-forming screws (T20).
 - 10b Screws (T25) connecting the plate to the positive terminals of capacitors 4, 8, 10, and 12. Number of screws varies with drive size.
11. Remove the insulator sheet between the DC(+) plate and the DC(-) plate.
12. Remove the DC(-) plate by removing:
 - 12a 1 standoff (8 mm) connecting the plate to the negative terminal of capacitor 2.
 - 12b Screws (T25) connecting the plate to the negative terminals of capacitors 1, 5, and 6. Number of screws varies with drive size.
13. Remove the plastic IGBT support (not shown) by removing 7 screws (T25).
14. Remove the IGBTs by removing 10 screws (T25) from each IGBT module.

Reassembly in 690 V AC units

For reassembly, refer to the replacement IGBT instructions that come with the spare parts kit.

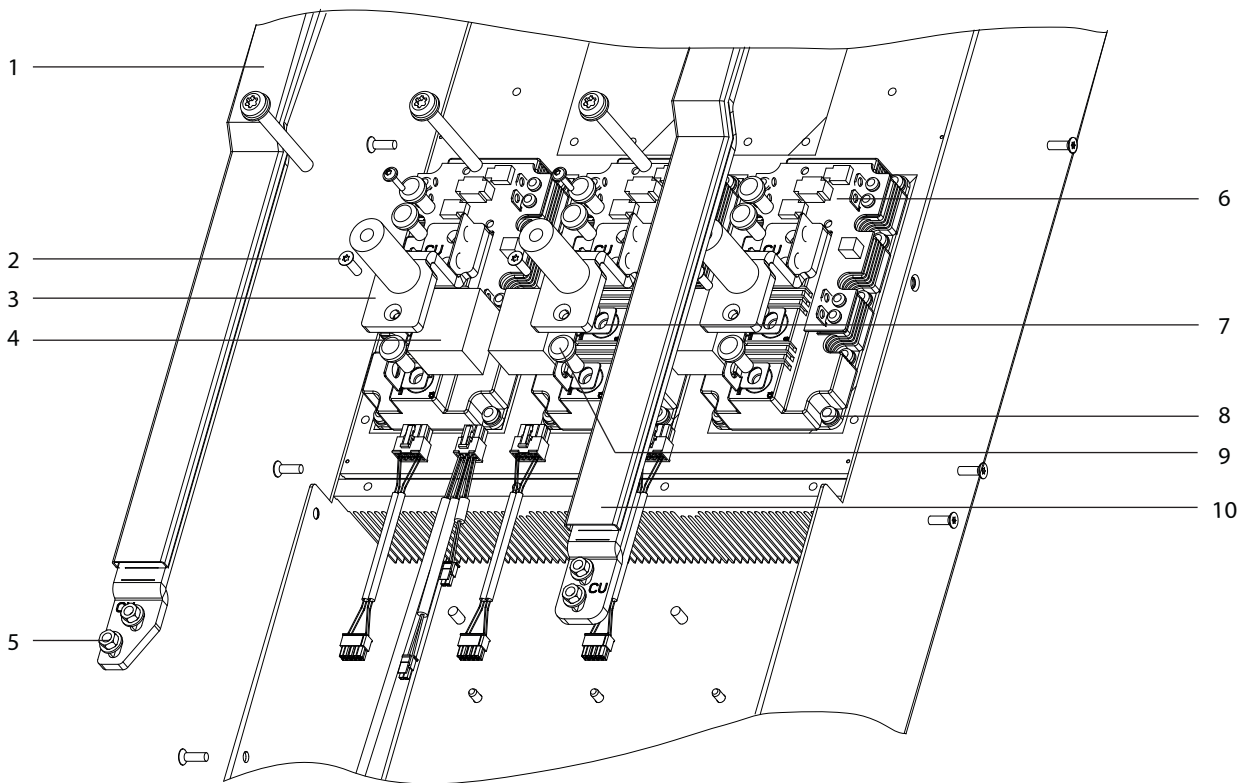

130BF858.10

1	DC(+) bus rail	6	IGBT module
2	Screw (T20)	7	IGBT output busbar
3	IGBT output busbar	8	IGBT terminal screw (T40)
4	Snubber capacitor	9	IGBT screw (T25)
5	Nut (8 mm)	10	DC(-) bus rail

Illustration 11.13 IGBT Modules

11.2.20 Standard DC Capacitors

To remove or reinstall the standard DC capacitors, use the following steps.

NOTICE

CAPACITOR REPLACEMENT

When replacing DC capacitors, always replace the entire bank of capacitors, even if only 1 DC capacitor has failed.

NOTICE

CAPACITOR TYPE

Drives can contain standard DC capacitors or twistlock capacitors. Use the standard DC capacitor instructions for drives manufactured prior to the following time period:

- 240/400 V AC units produced before week 18, 2018.
- 690 V AC units produced before week 23, 2018.

For excluded drives, see *chapter 11.2.22 Twistlock DC Capacitors*.

Disassembly in 400 V AC units

To remove the standard DC capacitors from 400 V DC units, use the following steps. Refer to *Illustration 11.14*.

1. Remove the gate drive card. Refer to *chapter 11.2.14 Gate Drive Card*.
2. Remove the balance/high frequency card. Refer to *chapter 11.2.13 Balance/High Frequency Card*.
3. Remove the DC bus rails. Refer to *chapter 11.2.18 DC Bus Rails*.
4. Remove the insulator sheet from the capacitor bank.
5. Remove the IGBT output busbars by removing 3 thread-forming screws (T20), 1 per busbar, and 6 screws (T40), 2 per busbar.
6. Remove the snubber capacitors, 1 from each IGBT module, by removing 2 screws (T40).
7. Remove the DC(+) plate by removing:
 - 7a The standoff (8 mm) connecting the plate to the positive terminal of capacitor 3.
 - 7b Screws (T25) connecting the plate to the positive terminals of capacitors 1, 2, 4, 9, and 12. The number of T25 screws varies based on the size of the drive.
8. Remove the insulator between the DC(+) plate and the DC(-) plate. If necessary, first remove the screws connecting the DC(-) plate and the DC center plate to the capacitors.
9. Remove the DC(-) plate by removing:

- 9a The standoff (8 mm) connecting the plate to the negative terminal of capacitor 6.
- 9b Screws (T25) connecting the plate to the negative terminals of capacitors 5, 7, 8, 10, and 11. The number of T25 screws varies based on the size of the drive.

10. Remove the insulator sheet between the DC(-) plate and the DC center plate. If necessary, first remove the screws connecting the DC center plate to the capacitors.
11. Remove the DC center plate by removing:
 - 11a The standoff (8 mm) connecting the plate to the negative terminal of capacitor 2.
 - 11b Screws (T25) connecting the plate to the negative terminal of capacitors 1, 3, 4, 9, and 12.
 - 11c Screws (T25) connecting the plate to the positive terminal of capacitors 5, 6, 7, 8, 10, and 11. The number of screws (T25) varies based on the size of the drive.
12. Remove the capacitor locking panel by removing the 10 thread-forming screws (T25).

Reassembly in 400 V AC units

Reinstall in reverse order of this procedure. Tighten hardware according to *chapter 14.1 Fastener Torque Ratings*.

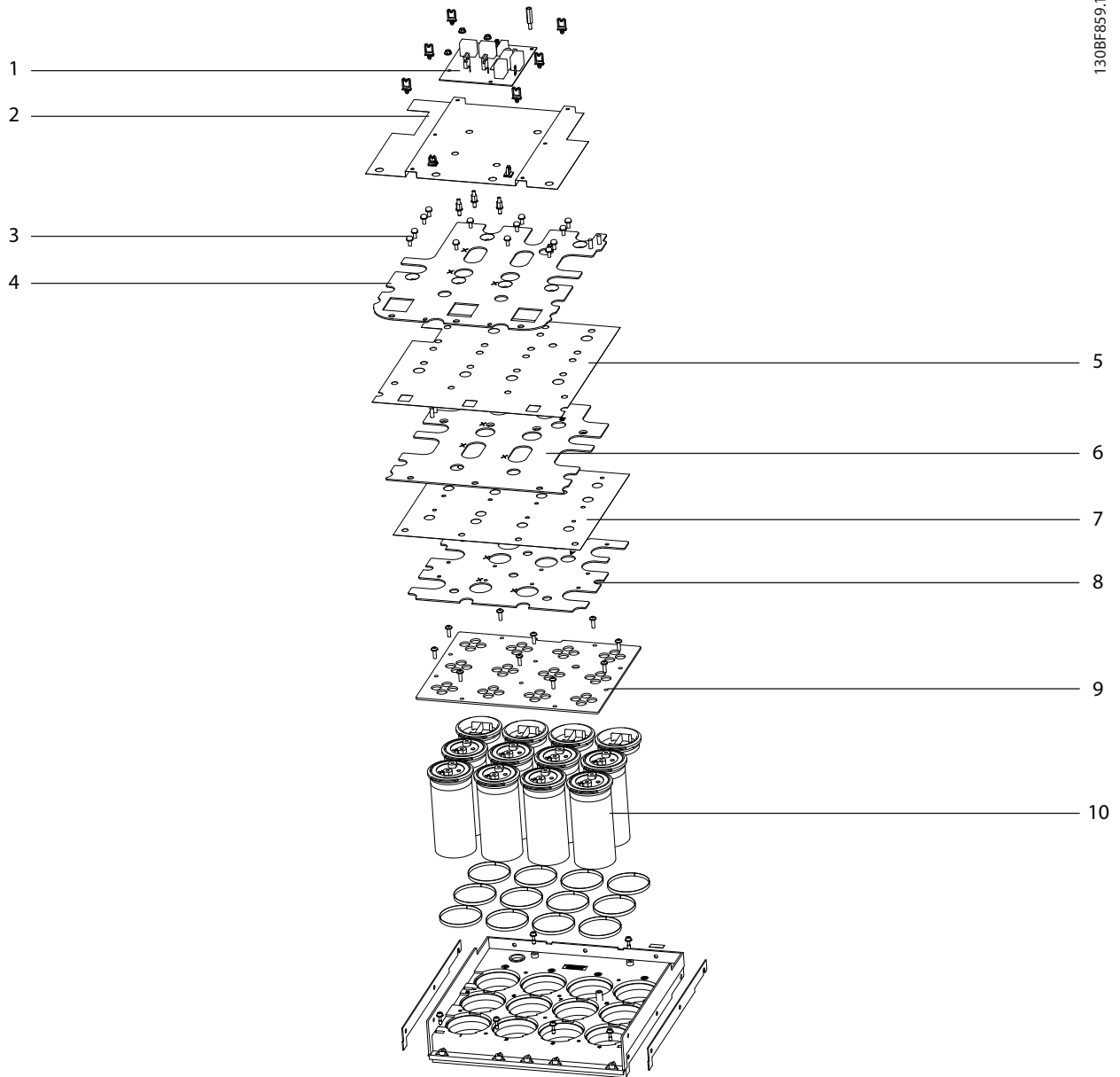

11

1	Balance/high frequency card	6	DC(-) plate
2	Capacitor bank cover	7	Insulator sheet
3	Screw (T25)	8	DC center capacitor plate
4	DC(+) plate	9	Capacitor locking plate
5	Insulator sheet	10	Standard DC capacitor

Illustration 11.14 Standard DC Capacitors, 400 V AC Unit

To remove the standard DC capacitors from 690 V AC units, use the following steps. Refer to *Illustration 11.15*.

Disassembly in 690 V AC units

1. Remove the gate drive card. Refer to *chapter 11.2.14 Gate Drive Card*.
2. Remove the balance/high frequency card. Refer to *chapter 11.2.13 Balance/High Frequency Card*.
3. Remove the DC bus rails. Refer to *chapter 11.2.18 DC Bus Rails*.
4. Remove the insulator sheet from the capacitor bank.
5. Remove the IGBT output busbars by removing 3 thread-forming screws (T20), 1 per busbar, and 6 screws (T40), 2 per busbar.
6. Remove the snubber capacitors, 1 from each IGBT module, by removing 2 screws (T40).
7. Remove the DC(+) plate by removing:
 - 7a Two thread-forming screws (T20).
 - 7b Screws (T25) connecting the plate to the positive terminals of capacitors 4, 8, 10, and 12. The number of screws (T25) varies based on the size of the drive.
8. Remove the insulator sheet between the DC(+) plate and the DC(-) plate. If necessary, first remove the screws connecting the DC(-) plate and the 2 DC center plates to the capacitors.
9. Remove the DC(-) plate by removing:
 - 9a The standoff (8 mm) connecting the plate to the negative terminal of capacitor 2.
 - 9b Screws (T25) connecting the plate to the negative terminals of capacitors 1, 5, and 6. The number of screws (T25) varies based on the size of the drive.
10. Remove the insulator sheet between the DC(-) plate and the 2 DC center plates. If necessary, first remove the screws connecting the 2 DC center plates to the capacitors.
11. Remove DC center plate 1 by removing:
 - 11a 1 standoff (8 mm) connecting the plate to the positive terminal of capacitor 7.
 - 11b Screws (T25) connecting the plate to the negative terminal of capacitors 4, 8, 10, and 12.
 - 11c Screws (T25) connecting the plate to the positive terminals of capacitors 3, 9, and 11. Number of screws (T25) varies based on the size of the drive.
12. Remove DC center plate 2 by removing:

- 12a 1 standoff (8 mm) connecting the plate to the positive terminal of capacitor 6.
 - 12b Screws (T25) connecting the plate to the negative terminal of capacitors 3, 7, 9, and 11.
 - 12c Screws (T25) connecting the plate to the positive terminals of capacitors 1, 2, and 5. The number of screws (T25) varies based on the size of the drive.
13. Remove the capacitor locking panel by removing 10 screws (T25 thread-forming).

Reassembly in 690 V AC units

Reinstall in reverse order of this procedure. Tighten hardware according to *chapter 14.1 Fastener Torque Ratings*.

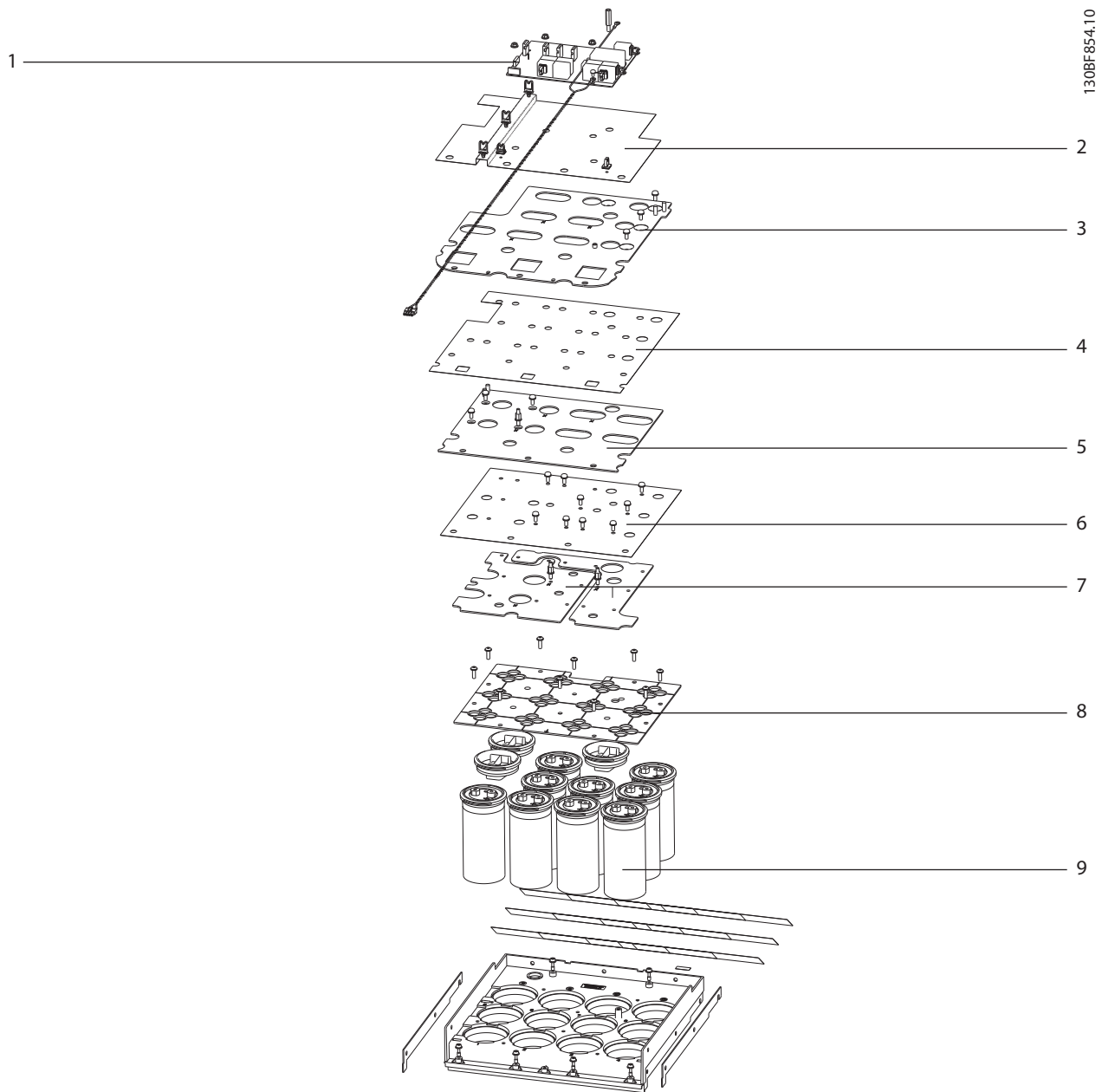

1	Balance/high frequency card	6	Insulator sheet
2	Capacitor bank cover	7	DC center plates
3	DC(+) plate	8	Capacitor locking panel
4	Insulator sheet	9	Standard DC capacitors
5	DC(-) plate	-	-

Illustration 11.15 Standard DC Capacitors, 690 V AC Unit

11.2.21 Standard DC Capacitor Bank Layouts

Standard DC capacitor banks differ in the number of capacitors present and the location of fasteners, such as screws and standoffs. The drive size and power rating determine the layout of the capacitor bank. Use *Table 11.3* and *Table 11.4* to find the capacitor bank layout for a particular drive in D2h/D4h/D7h/D8h/J9 sizes. Each illustration includes a table that lists which fasteners are screws or standoffs, and which DC bus plate or midplate they secure.

Graphic reference	Model	
	FC 102, FC 103, and FC 202	FC 302
<i>Illustration 11.17</i>	N200	N160
<i>Illustration 11.18</i>	N250	N200
<i>Illustration 11.19</i>	N315	N250

Table 11.3 Standard DC Capacitor Bank Layout 380–480/500 V

Graphic reference	Model	
	FC 102, FC 103, and FC 202	FC 302
<i>Illustration 11.20</i>	N200	N160
<i>Illustration 11.20</i>	N250	N200
<i>Illustration 11.21</i>	N315	N250
<i>Illustration 11.21</i>	N400	N315

Table 11.4 Standard DC Capacitor Bank Layout 525–690 V

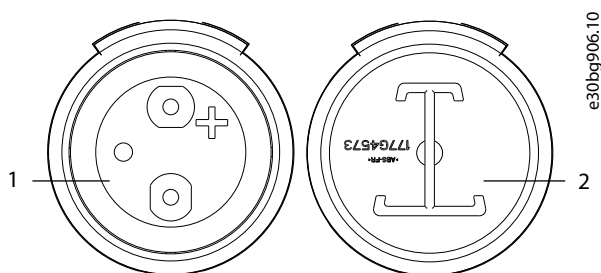

1	Standard DC capacitor
2	Plug

Illustration 11.16 Standard DC Capacitor and Plug

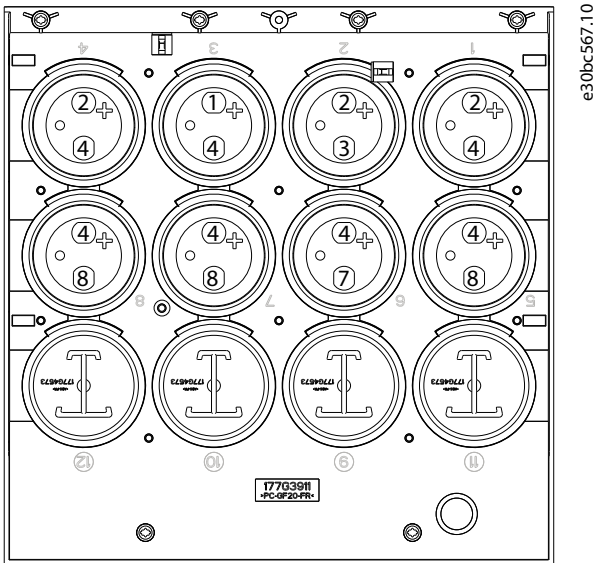

1	DC(+) plate standoff
2	DC(+) plate screw
3	Midplate 1 standoff
4	Midplate 1 screw
5	Midplate 2 standoff
6	Midplate 2 screw
7	DC(-) plate standoff
8	DC(-) plate screw

Illustration 11.17 Standard DC Cap Bank with 8 Capacitor Layout

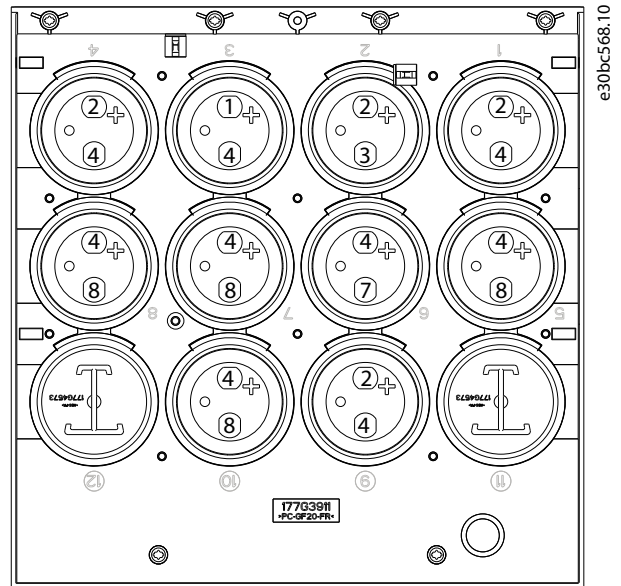

1	DC(+) plate standoff
2	DC(+) plate screw
3	Midplate 1 standoff
4	Midplate 1 screw
5	Midplate 2 standoff
6	Midplate 2 screw
7	DC(-) plate standoff
8	DC(-) plate screw

Illustration 11.18 Standard DC Cap Bank with 10 Capacitor Layout

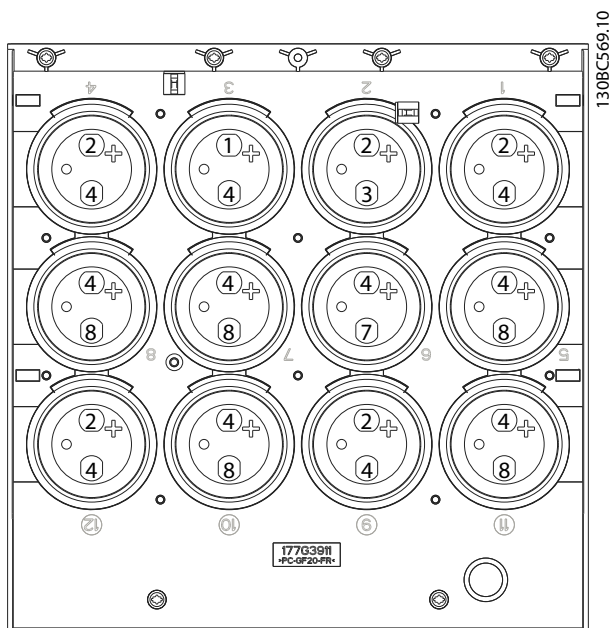

1	DC(+) plate standoff
2	DC(+) plate screw
3	Midplate 1 standoff
4	Midplate 1 screw
5	Midplate 2 standoff
6	Midplate 2 screw
7	DC(-) plate standoff
8	DC(-) plate screw

Illustration 11.19 Standard DC Cap Bank with 12 Capacitor Layout

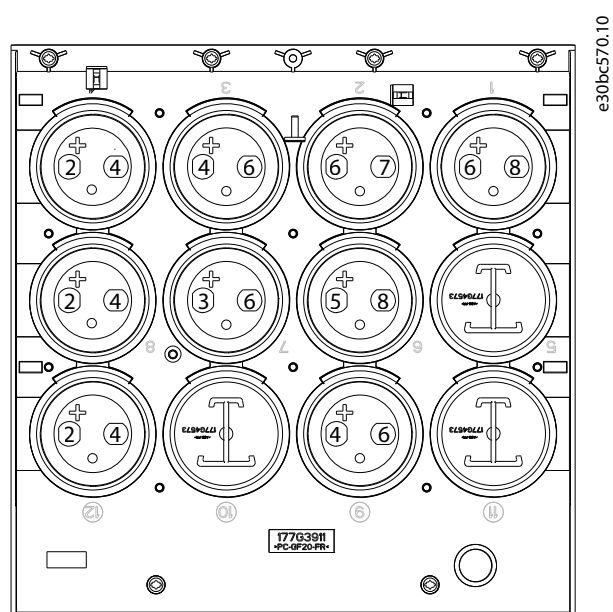

1	DC(+) plate standoff
2	DC(+) plate screw
3	Midplate 1 standoff
4	Midplate 1 screw
5	Midplate 2 standoff
6	Midplate 2 screw
7	DC(-) plate standoff
8	DC(-) plate screw

Illustration 11.20 Standard DC Cap Bank with 9 Capacitor Layout

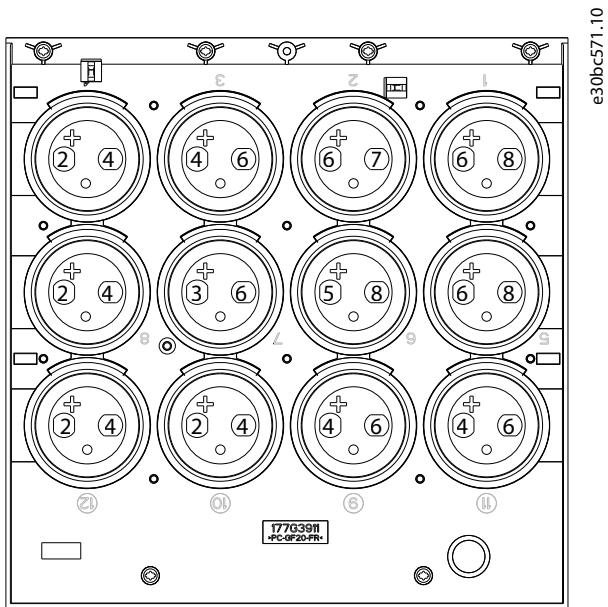

1	DC(+) plate standoff
2	DC(+) plate screw
3	Midplate 1 standoff
4	Midplate 1 screw
5	Midplate 2 standoff
6	Midplate 2 screw
7	DC(-) plate standoff
8	DC(-) plate screw

Illustration 11.21 Standard DC Cap Bank 12 Capacitor Layout

11.2.22 Twistlock DC Capacitors

To remove or reinstall twistlock DC capacitors, use the following steps.

NOTICE

CAPACITOR REPLACEMENT

When replacing DC capacitors, always replace the entire bank of capacitors, even if only 1 DC capacitor has failed.

NOTICE

CAPACITOR TYPE

Drives can contain standard DC capacitors or twistlock DC capacitors. Use the twistlock DC capacitor instructions for drives manufactured within the following time period.

- 240/400 V drives produced week 18, 2018 or after.
- 690 V drives produced week 23, 2018 or after.

For all other drives of this size, refer to *chapter 11.2.20 Standard DC Capacitors*.

Disassembly in 240/400 V AC units

To remove the twistlock DC capacitors from 240/400 V AC units, use the following steps. Refer to *Illustration 11.22*.

1. Remove the gate drive card. Refer to *chapter 11.2.14 Gate Drive Card*.
2. Remove the balance/high frequency card. Refer to *chapter 11.2.13 Balance/High Frequency Card*.
3. Remove the DC bus rails. Refer to *chapter 11.2.18 DC Bus Rails*.
4. Remove insulator sheet 1 from the capacitor bank.
5. To remove the IGBT output busbars:
 - 5a Remove 3 thread-forming screws (T20), 1 per busbar.
 - 5b Remove 6 screws (T40), 2 per busbar.
6. Remove the snubber capacitors, 1 from each IGBT module, by removing 2 screws (T40) from each snubber capacitor.
7. To remove the DC(+) plate:
 - 7a Remove 1 standoff (8 mm) connecting the DC(+) plate to the positive terminal of capacitor 3.
 - 7b Remove the screws (T25) connecting the DC(+) plate to the positive terminals of capacitors 1, 2, 4, 9, and 12. The number of screws varies based on the size of the drive.
8. Remove insulator sheet 2 from between the DC(+) plate and the DC(-) plate. If necessary, first remove the screws connecting the DC(-) plate and the midplate to the capacitors.
9. To remove the DC(-) plate:
 - 9a Remove 1 standoff (8 mm) connecting the DC(-) plate to the negative terminal of capacitor 6.
 - 9b Remove the screws (T25) connecting the DC(-) plate to the negative terminals of capacitors 5, 7, 8, 10, and 11. The number of screws varies based on the size of the drive.
10. Remove insulator sheet 3 from between the DC(-) plate and the midplate. If necessary, first remove the screws connecting the midplate to the capacitors.
11. To remove the midplate:
 - 11a Remove 1 standoff (8 mm) connecting the midplate to the negative terminal of capacitor 2.
 - 11b Remove the screws (T25) connecting the midplate to the negative terminal of capacitors 1, 3, 4, 9, and 12. The number of screws varies based on the size of the drive.
 - 11c Remove the screws (T25) connecting the plate to the positive terminal of capacitors 5, 6, 7, 8, 10, and 11. The number of screws varies based on the size of the drive.
12. Remove the capacitor locking panel by removing the 10 thread-forming screws (T25).
13. To remove a twistlock DC capacitor, use the special tool provided in the parts kit (or grip the edges with a large pliers).
14. Turn the twistlock DC capacitor approximately 30° counterclockwise to release it. Pull the capacitor out of the housing.

Reassembly in 240/400 V AC units

Reinstall in reverse order of this procedure. Tighten hardware according to *chapter 14.1 Fastener Torque Ratings*.

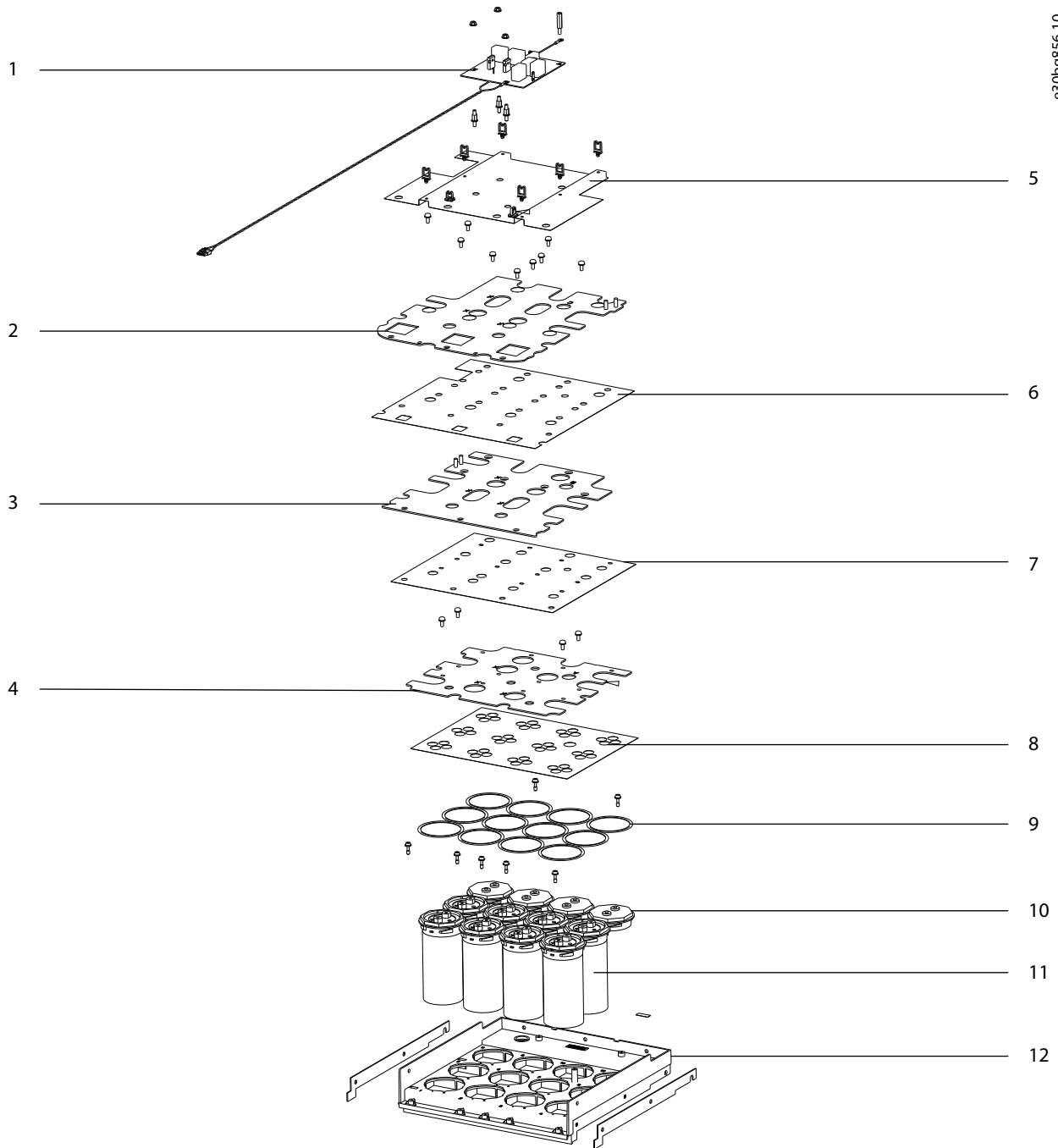

e30bg856.10

1	Balance/high frequency card	7	Insulator sheet 3
2	DC(+) plate	8	Capacitor locking plate
3	Midplate	9	Capacitor gasket
4	DC(-) plate	10	Plug
5	Insulator sheet 1	11	Twistlock DC capacitor
6	Insulator sheet 2	12	Capacitor bank housing

Illustration 11.22 DC Twistlock Capacitors, 240/400 V AC Unit

690 V AC Power Size

To remove the twistlock DC capacitors from 690 V AC units, use the following steps. Refer to *Illustration 11.23*.

Disassembly in 690 V AC units

1. Remove the gate drive card. Refer to *chapter 11.2.14 Gate Drive Card*.
2. Remove the balance/high frequency card. Refer to *chapter 11.2.13 Balance/High Frequency Card*.
3. Remove the DC bus rails. Refer to *chapter 11.2.18 DC Bus Rails*.
4. Remove insulator sheet 1.
5. To remove the IGBT output busbars:
 - 5a Remove 3 thread-forming screws (T20), 1 per busbar.
 - 5b Remove 6 screws (T40), 2 per busbar.
6. Remove the snubber capacitors, 1 from each IGBT module, by removing 2 screws (T40) from each snubber capacitor.
7. To remove the DC(+) plate:
 - 7a Remove 2 thread-forming screws (T20).
 - 7b Remove 4 screws (T25) connecting the plate to the positive terminals of capacitors 4, 8, 10, and 12. Number of screws varies based on the size of the drive.
8. Remove insulator sheet 2. If necessary, first remove the screws connecting the DC(-) plate and the 2 midplates to the capacitors.
9. To remove the DC(-) plate:
 - 9a Remove 1 standoff (8 mm) connecting the DC(-) plate to the negative terminal of capacitor 2.
 - 9b Remove the screws (T25) connecting the DC(-) plate to the negative terminals of capacitors 1, 5, and 6. Number of screws varies based on the size of the drive.
10. Remove insulator sheet 3 between the DC(-) plate and the 2 midplates. If necessary, first remove the screws connecting the 2 midplates to the capacitors.
11. To remove midplate 1:
 - 11a Remove 1 standoff (8 mm) connecting midplate 1 to the positive terminal of capacitor 7.
 - 11b Remove the screws (T25) connecting midplate 1 to the negative terminal of capacitors 4, 8, 10, and 12. Number of

screws varies based on the size of the drive.

- 11c Remove the screws (T25) connecting midplate 1 to the positive terminals of capacitors 3, 9, and 11. Number of screws varies based on the size of the drive.

12. To remove midplate 2:

- 12a Remove 1 standoff (8 mm) connecting midplate 2 to the positive terminal of capacitor 6.

- 12b Remove the screws (T25) connecting midplate 2 to the negative terminal of capacitors 3, 7, 9, and 11.

- 12c Remove the screws (T25) connecting midplate 2 to the positive terminals of capacitors 1, 2, and 5. Number of screws varies based on the size of the drive.

13. Remove the capacitor locking panel by removing 10 thread-forming screws (T25).

14. To remove a twistlock DC capacitor, use the special tool provided in the parts kit (or grip the edges with a large pliers).

15. Turn the twistlock DC capacitor approximately 30° counterclockwise to release it. Pull the capacitor out of the housing.

Reassembly in 690 V AC units

Reinstall in reverse order of this procedure. Tighten hardware according to *chapter 14.1 Fastener Torque Ratings*.

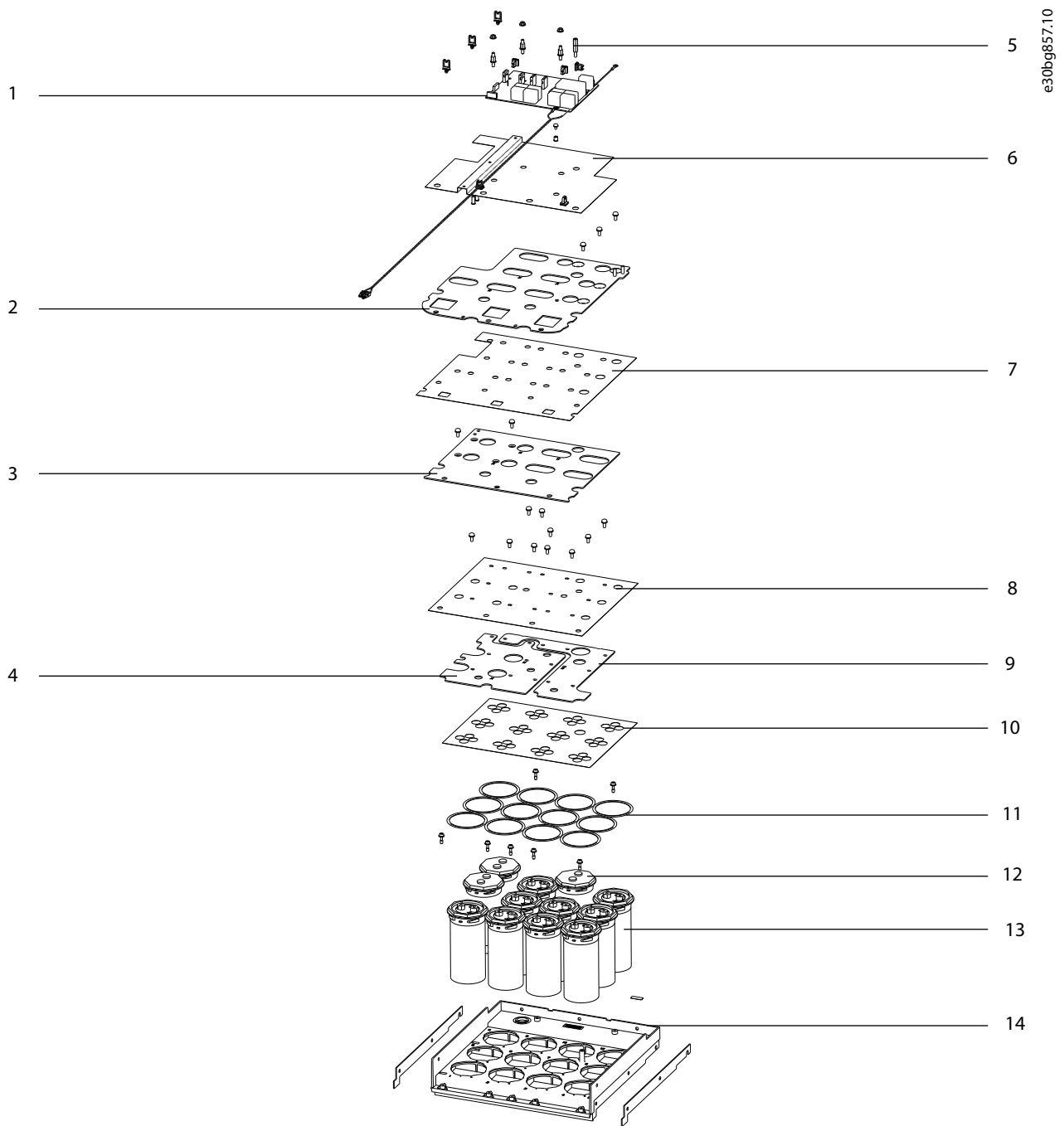

e30b9857.10

1	Balance/high frequency card	8	Insulator sheet 3
2	DC(+) plate	9	Midplate 2
3	Midplate 1	10	Capacitor locking panel
4	DC(-) plate	11	O-ring gasket
5	Standoff	12	Plug
6	Insulator sheet 1	13	Twistlock DC capacitor
7	Insulator sheet 2	14	Capacitor bank housing

Illustration 11.23 Twistlock DC Capacitors, 690 V AC Unit

11.2.23 Twistlock DC Capacitor Bank Layouts

Twistlock DC capacitor banks differ in the number of capacitors and plugs present and the location of fasteners, such as screws and standoffs. The drive size and power rating determine the layout of the twistlock DC capacitor bank. Use *Table 11.5* to *Table 11.7* to find the twistlock DC capacitor bank layout for a particular drive in D2h/D4h/D7h/D8h/J9 sizes.

Graphic reference	Model	
	FC 102, FC 103, and FC 202	FC 302
<i>Illustration 11.25</i>	N90K	N75K
<i>Illustration 11.25</i>	N110	N90K
<i>Illustration 11.26</i>	N150	N110
<i>Illustration 11.27</i>	N160	N150

Table 11.5 Twistlock DC Capacitor Bank Layout 200–240 V

Graphic reference	Model	
	FC 102, FC 103, and FC 202	FC 302
<i>Illustration 11.25</i>	N200	N160
<i>Illustration 11.26</i>	N250	N200
<i>Illustration 11.27</i>	N315	N250

Table 11.6 Twistlock DC Capacitor Bank Layout 380–500 V

Graphic reference	Model	
	FC 102, FC 103, and FC 202	FC 302
<i>Illustration 11.28</i>	N200	N160
<i>Illustration 11.28</i>	N250	N200
<i>Illustration 11.29</i>	N315	N250
<i>Illustration 11.29</i>	N400	N315

Table 11.7 Twistlock DC Capacitor Bank Layout 525–690 V

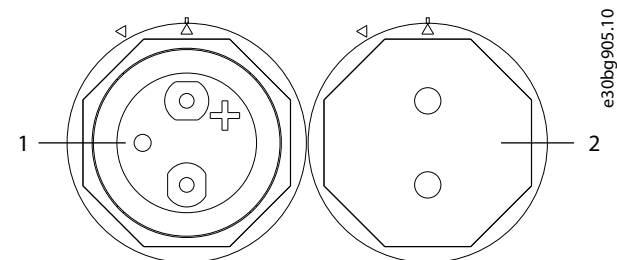

1	Twistlock DC capacitor
2	Plug

Illustration 11.24 Twistlock DC Capacitor and Plug

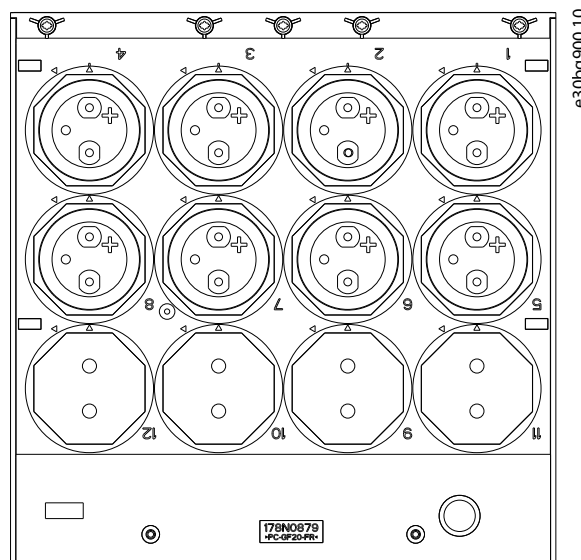

Illustration 11.25 Twistlock 8-Capacitor Layout

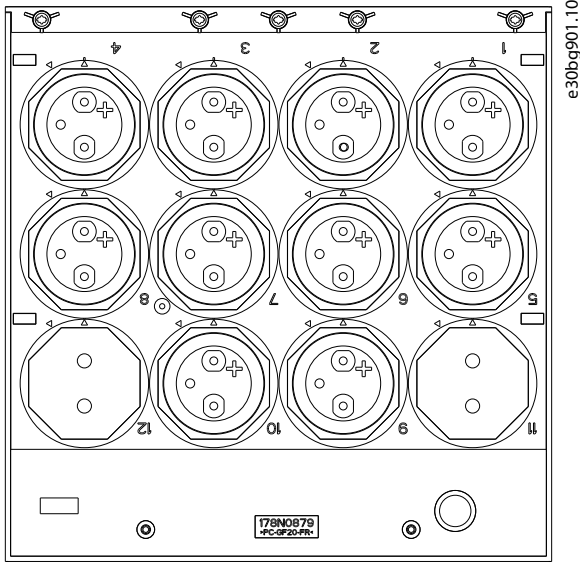

Illustration 11.26 Twistlock 10-Capacitor Layout

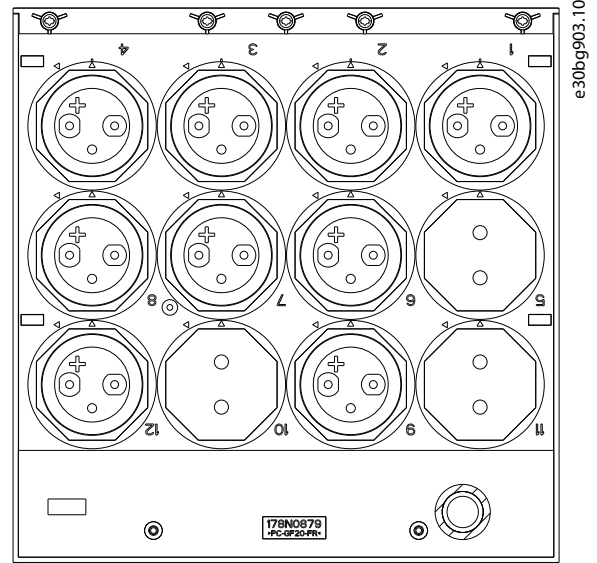

Illustration 11.28 Twistlock 9-Capacitor Layout

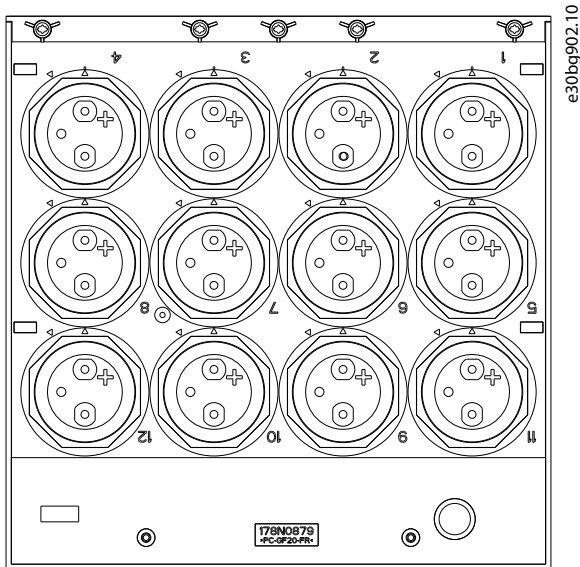

Illustration 11.27 Twistlock 12-Capacitor Layout

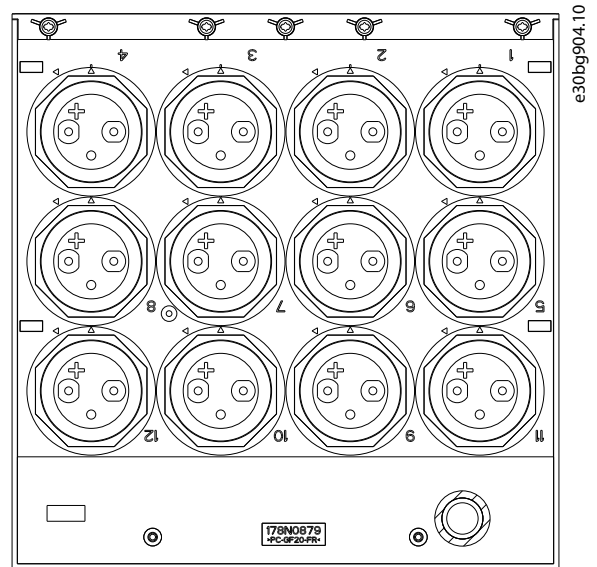

Illustration 11.29 Twistlock 12-Capacitor Layout

11.2.24 Brake IGBT Module

Drives configured with the brake option have a brake IGBT module. To remove or reinstall the optional brake IGBT module, use the following steps. Refer to *Illustration 11.30*.

Disassembly

1. Remove the gate drive card. See *chapter 11.2.14 Gate Drive Card*.
2. Remove the DC bus rails. Refer to *chapter 11.2.18 DC Bus Rails*.
3. Remove the snubber capacitor and 3 busbars from the brake IGBT module by removing 3 screws (T40).
4. Remove the insulator shield by removing 2 plastic standoffs.
5. Remove the SCR input busbars. See *chapter 11.2.16 SCR Input Busbars*.
6. Remove the brake IGBT module by removing 10 screws (T25).

Reassembly

For reassembly, use the replacement brake IGBT instructions provided with the spare parts kit.

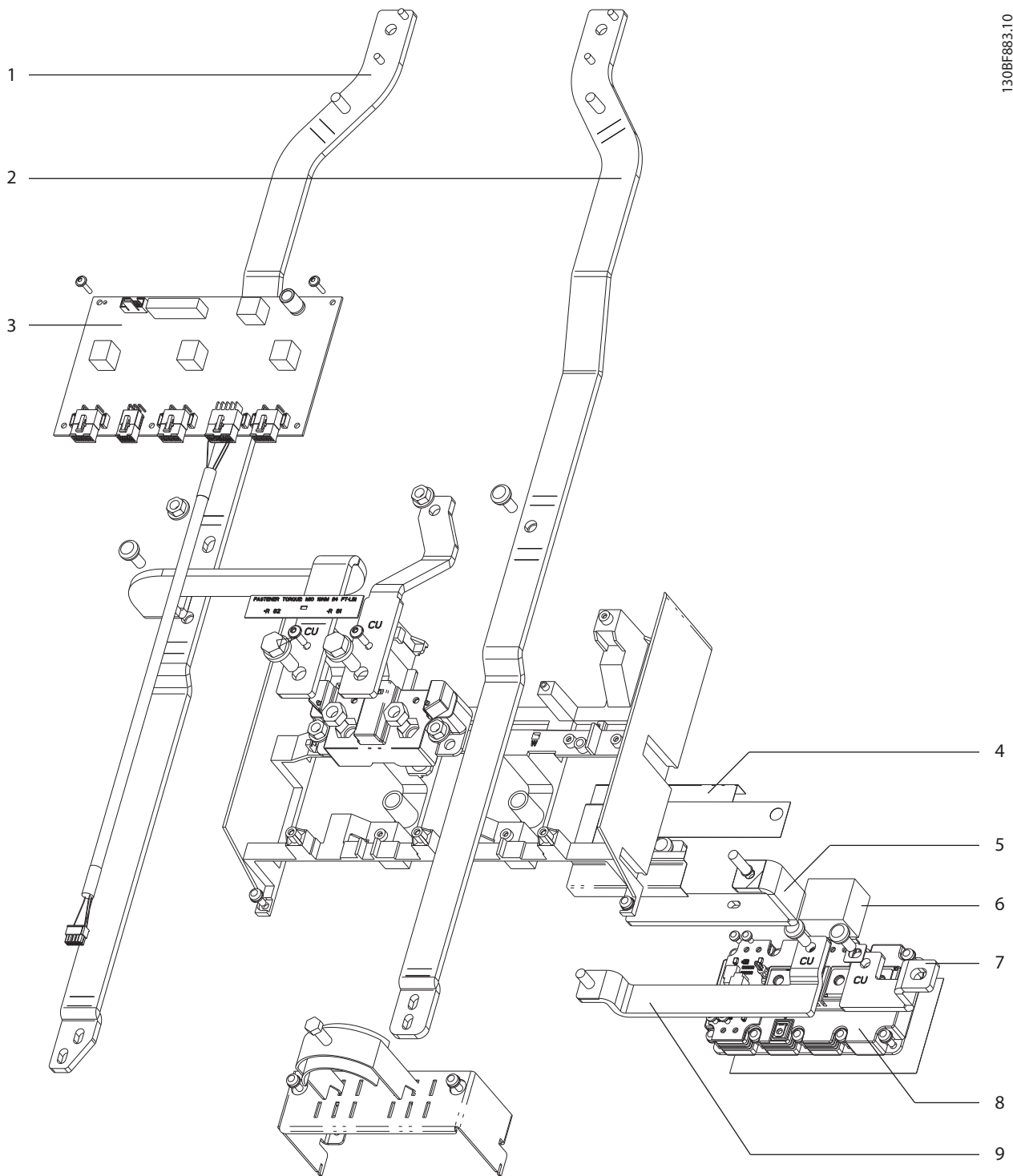

11

1	DC(+) bus rail	6	Snubber capacitor
2	DC(-) bus rail	7	DC(-) to brake IGBT busbar
3	Gate drive card	8	Brake IGBT module
4	Insulator shield	9	DC(+) to brake IGBT busbar
5	Brake IGBT output to R(-) terminal busbar	-	-

Illustration 11.30 Brake IGBT Module

11.2.25 Heat Sink Fan

To remove or reinstall the heat sink fan, use the following steps. For IP20/Chassis drives, see *Illustration 11.32*. For IP21/IP54 (UL type 1/12) Drives, see *Illustration 10.24*.

NOTICE

HEAT SINK FAN ACCESS

If there is an extended options cabinet connected to the drive, see *chapter 11.3.2 Accessing the Heat Sink Fan in D7h/D8h Drives*.

Disassembly

1. To access the heat sink fan when an optional telescoping duct is installed:
 - 1a Remove 6 nuts (T25) from the duct flange that attaches the duct to the bottom of the drive. See *Illustration 11.31*.
 - 1b Lower the telescoping duct so that the heat sink fan cover is accessible.
2. Remove the heat sink fan cover by removing 2 captive screws (T25). Take care not to damage wiring inside the drive.
3. Lift the heat sink fan off the mounting studs and lift it out of the drive. The heat sink fan cable is still connected.
4. Squeeze together the top portion of the black rubber cable grommet until it pops through the hole, releasing the heat sink fan cable.
5. Disconnect the heat sink fan cable connector. To avoid dropping the end of the cable into the drive, affix the loose cable to the drive with adhesive tape.

Reassembly

Tighten hardware according to *chapter 14.1 Fastener Torque Ratings*.

1. Attach the heat sink fan cable connector to the fan cable.
2. Feed the fan cable back through the access hole. Press together the top of the rubber fan grommet until it pops into place in the hole.
3. Place the heat sink fan over the mounting studs.
4. Replace the heat sink fan cover by securing 2 captive screws (T25). Torque to 2.3 Nm (20 in-lb).
5. If an optional telescoping duct is installed, extend the duct upward and secure the duct flange to the drive with 6 nuts (T25).

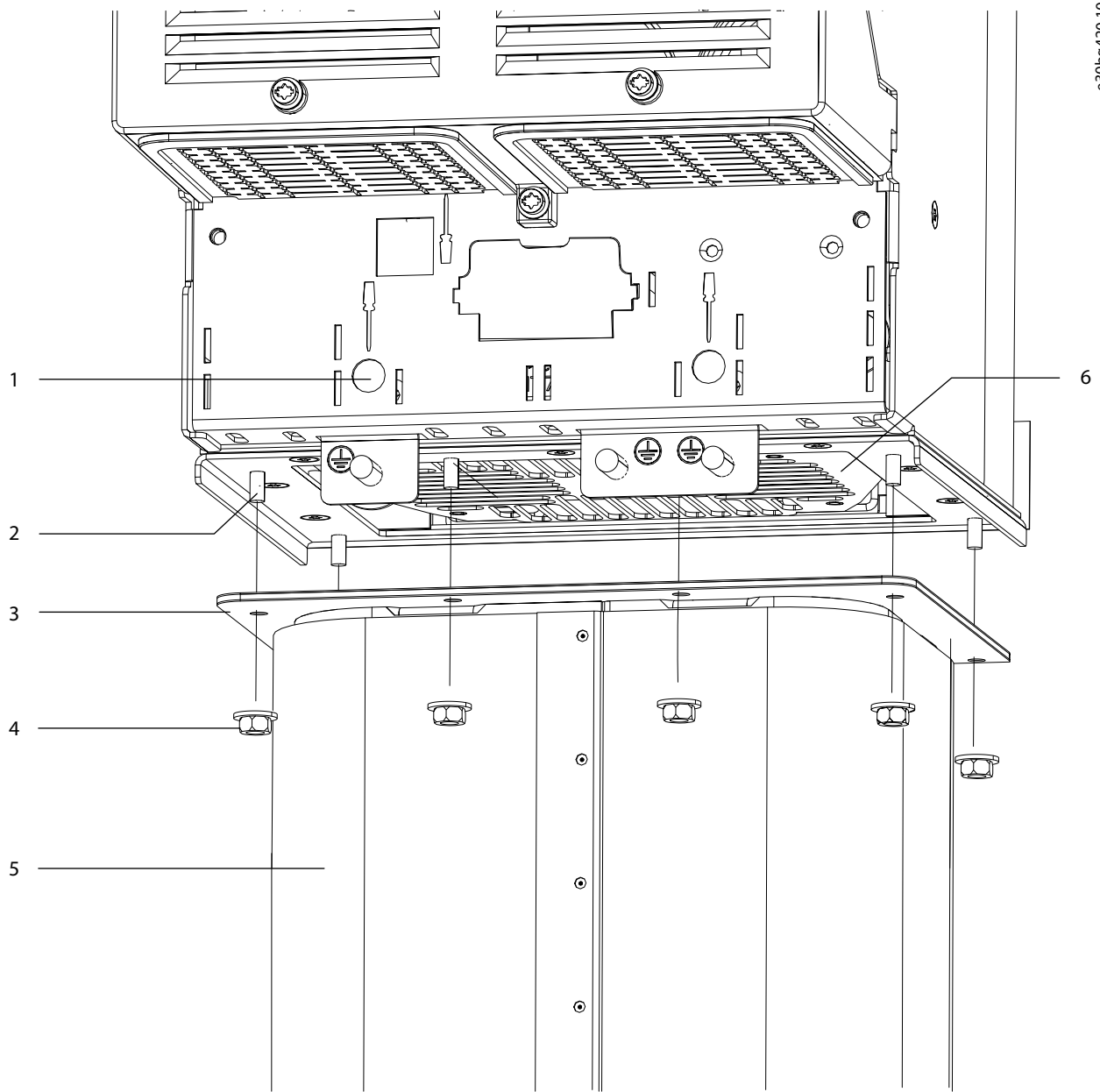

e30bg420.10

1	Screwdriver access holes for captive screws (T25)	4	Nut (T25)
2	Threaded stud	5	Telescoping duct
3	Duct flange	6	Heat sink fan cover

Illustration 11.31 Heat Sink Fan Access with Telescoping Cooling Duct

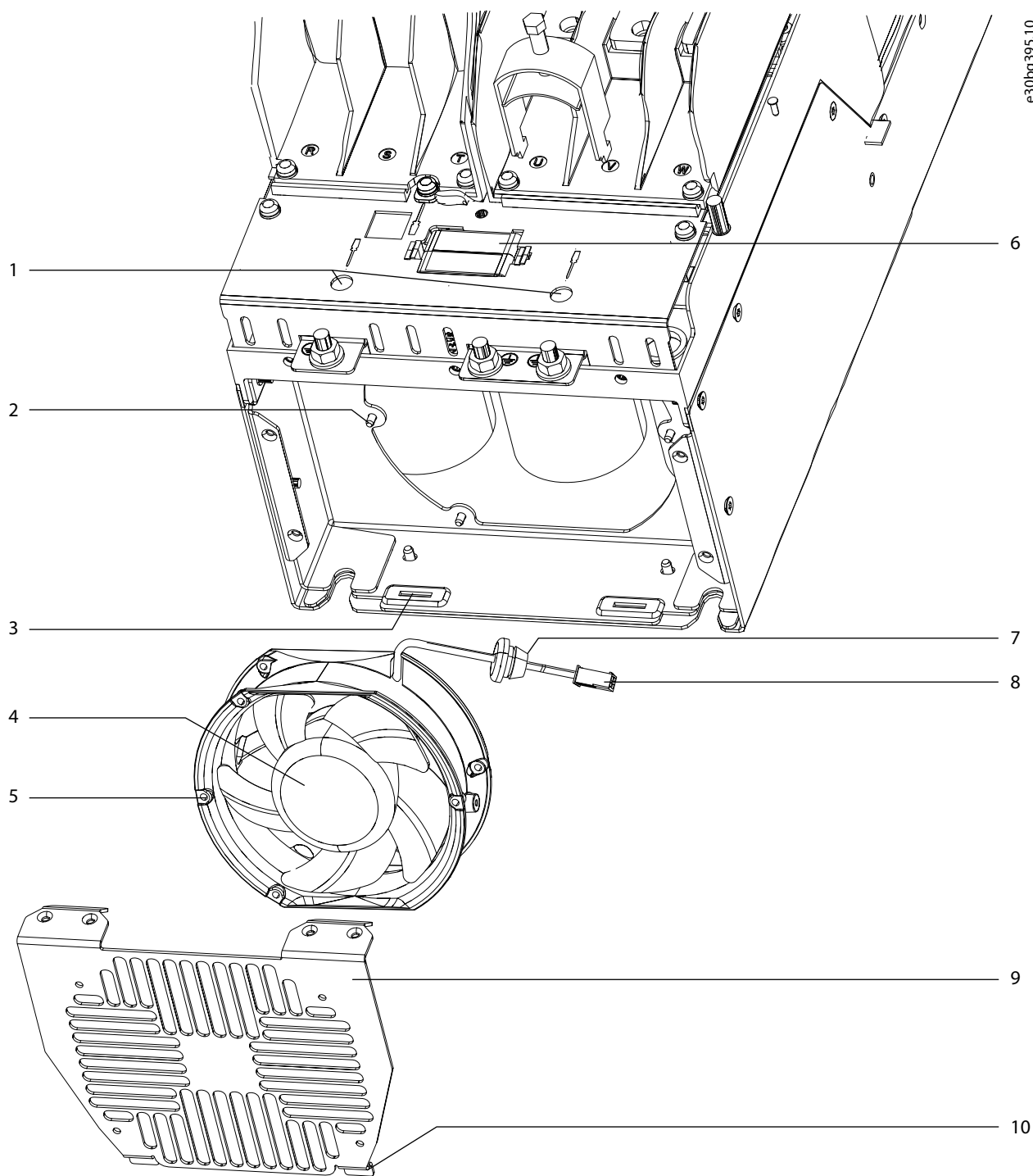

11

1	Screwdriver access holes for captive screws (T25)	6	Mixing fan
2	Mounting studs	7	Cable grommet
3	Slot for fan cover	8	Fan cable connector
4	Heat sink fan	9	Fan cover
5	Mounting holes	10	Fan cover tabs

Illustration 11.32 Heat Sink Fan in IP20/Chassis Drives

11.2.26 Door Fan

Door fans are found in only IP21 (UL type 1) and IP54 (UL type 12) enclosures and extended option cabinets. To remove or reinstall a door fan, use the following steps. See *Illustration 11.33* and *Illustration 11.34*.

Disassembly

1. Pinch together the release tabs on the door fan front grill and remove the grill from the enclosure door.
2. Remove the door fan filter.
3. Open the enclosure door and unplug the in-line connector attaching the door fan cable.
4. Release the cable from the cable guides.
5. Detach 4 screws (T20) from the corners of the door fan. When removing the screws, hold each nut (7 mm) with a wrench on the opposite side of the door.
6. Remove the door fan from the enclosure door.
7. Using a pliers, pinch together the post in each corner of the door fan guard to release it from the fan.

NOTICE

FAN DIRECTION

To ensure proper cooling, position the door fan so that the air direction arrow points away from the internal drive components when the door is closed.

Reassembly

Tighten hardware according to *chapter 14.1 Fastener Torque Ratings*.

1. Align the posts on the door fan guard with the holes in the corners of the door fan and press together.
2. Position the door fan in the door of the enclosure. Check that the air direction arrow points away from the interior of the drive when the door is closed.
3. Replace 4 screws (T20) in the corners of the door fan, securing each with a nut (7 mm).
4. Route the door fan cable through the cable guides and attach the in-line cable connector.
5. Replace the filter over the door fan on the outside of the door.
6. Reposition the door fan grill over the filter and press to snap in place.

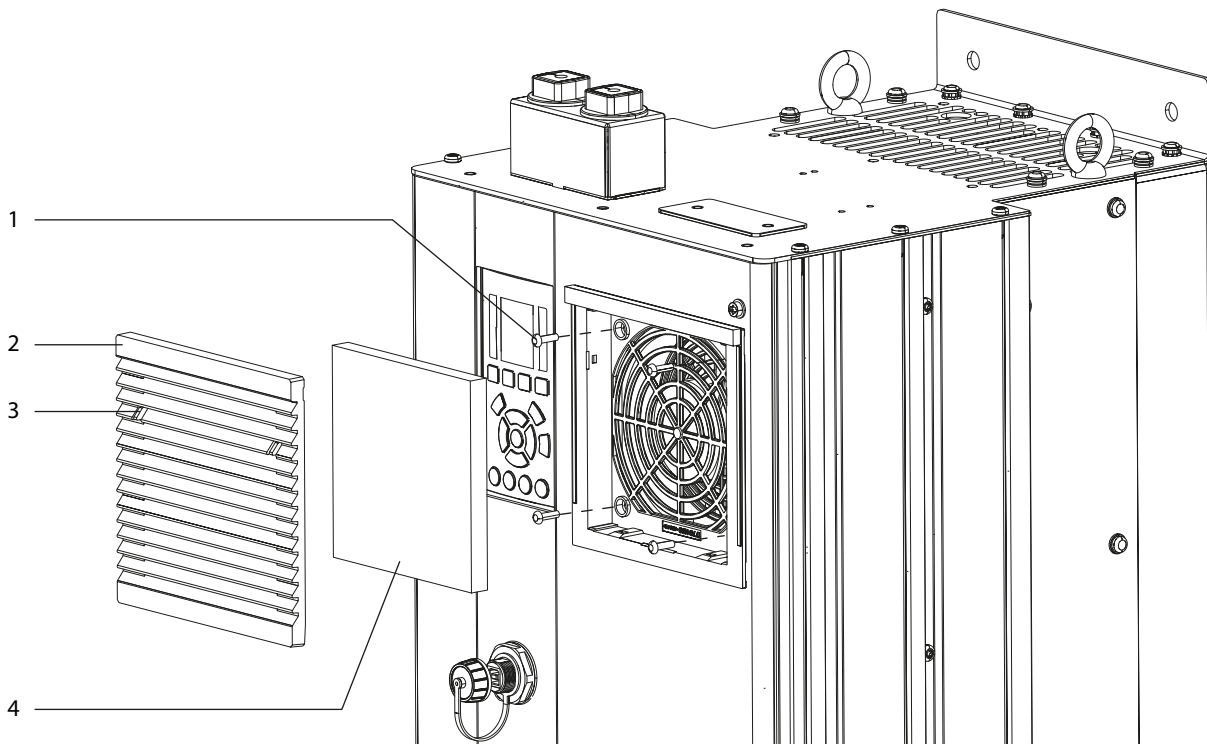

e30bg286.10

1	Screw (T20)	3	Release tab
2	Door fan front grill	4	Door fan filter

Illustration 11.33 Front View of Door Fan Assembly

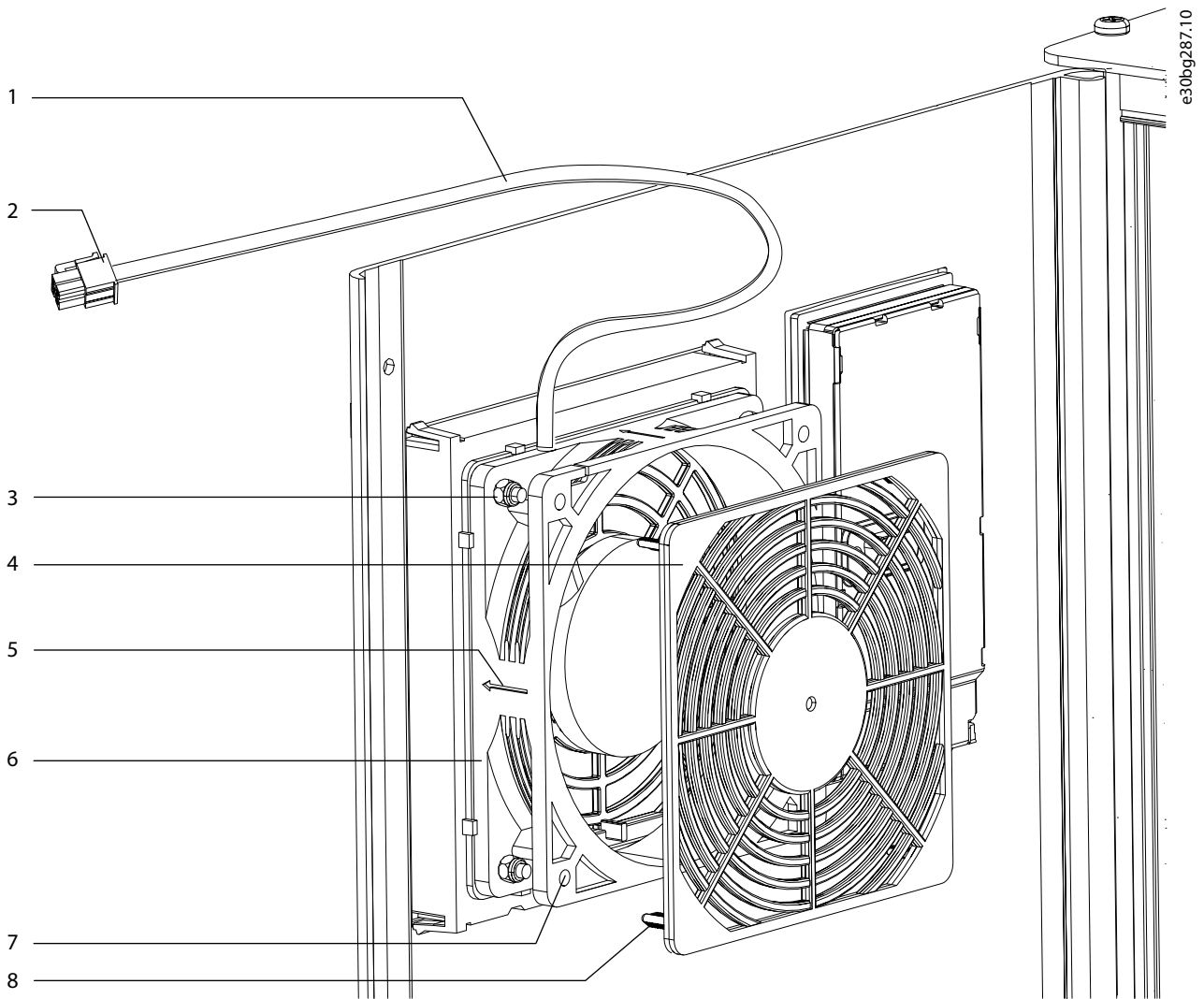

11

1	Door fan cable	5	Air direction arrow
2	Cable connector	6	Door fan
3	Nut (7 mm)	7	Hole for corner post
4	Door fan guard	8	Corner post

Illustration 11.34 Interior View of Door Fan Assembly

11.2.27 Top Fan

The top fan is present in IP20/Chassis units only. The top fan assembly includes 1 fan in a housing or secured under a sheet metal or wire grill. To remove or reinstall the top fan, use the following steps. See *Illustration 11.35* and *Illustration 11.36*.

Disassembly

1. Unfasten 2 screws (T25) and remove the front cover from the unit.
2. Unplug the top fan cable connector.
3. Pull the top fan cable through the cable access hole, freeing it from the enclosure.
4. If a fan housing is present, perform the following steps. See *Illustration 10.27*. Otherwise, proceed to the next step.
 - 4a Remove 2 screws (T25) from the top fan housing.
 - 4b Slide the fan housing and top fan out from under the retaining clips on top of the drive.
5. If a wire or sheet metal grill is present, perform the following steps. See *Illustration 10.28*.
 - 5a Remove 2 screws (T25) from opposite corners of the top fan grill.
 - 5b Lift the grill and top fan from the drive.

Reassembly

Tighten hardware according to *chapter 14.1 Fastener Torque Ratings*.

1. Feed the top fan cable through the cable access hole on the top of the drive.
2. Reconnect the in-line fan cable connector.
3. If a fan housing is present, perform the following steps. See *Illustration 10.27*. Otherwise, proceed to the next step.
 - 3a Place the top fan in the fan housing. Check that the air direction arrows point upward and away from the drive.
 - 3b Slide the top fan housing and fan under the retaining clips on top of the drive.
 - 3c Fasten 2 screws (T25) in the top fan housing, securing it to the drive.
4. If a wire or sheet metal grill is present, perform the following steps. See *Illustration 10.28*.
 - 4a Position the fan on top of the drive. Check that the air direction arrows point upward and away from the drive.
 - 4b Place the grill on top of the fan.
 - 4c Fasten 2 screws (T25) in opposite corners of the grill, securing the top fan to the drive.
5. Replace the front cover on the drive, and fasten with 2 screws (T25).

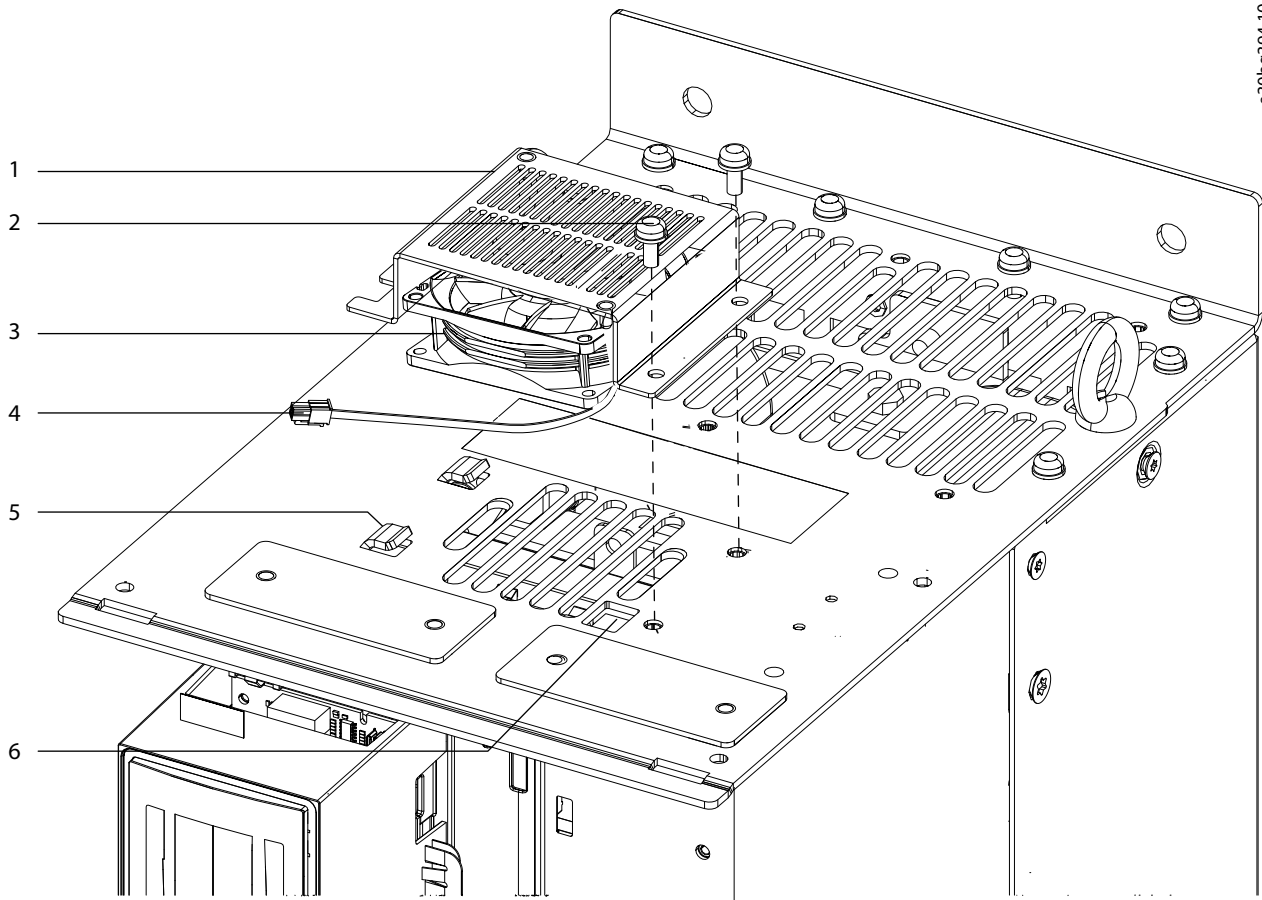

11

1	Top fan housing	4	Top fan cable and connector
2	Screw (T25)	5	Retaining clip
3	Top fan	6	Cable access hole

Illustration 11.35 Top Fan with Housing

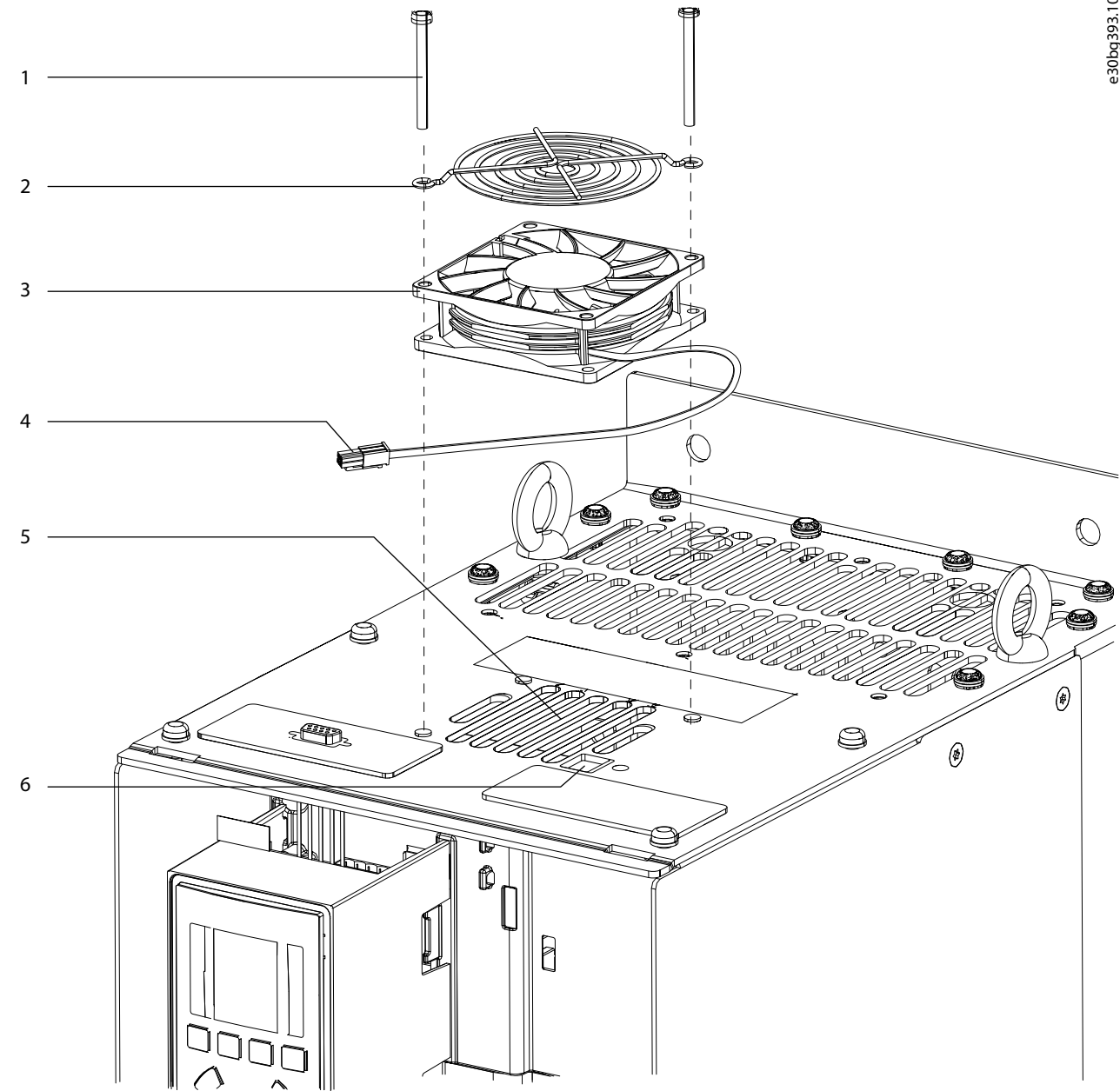

1	Screw (T25)	4	Top fan cable and connector
2	Top fan grill	5	Top vent
3	Top fan	6	Cable access hole

Illustration 11.36 Top Fan with Grill

11.3 D7h/D8h Disassembly and Assembly

The D7h and D8h drives are D2h drives with extended options cabinets. The unit profiled here includes a contactor, disconnect, and brake option, and is 690 V power range. Some procedures apply to all configurations, but some vary depending on the size of the drive, extended options cabinet, and selected options.

11.3.1 Removing the Drive from the Extended Options Cabinet

To remove the drive from the extended options cabinet, use the following steps. Refer to *Illustration 11.37*.

NOTICE

DRIVE WEIGHT

The D8h drive is heavy. To avoid injury, remove it from the extended options cabinet using 2 people or appropriate equipment for lifting.

NOTICE

FASTENER REMOVAL

When removing the fasteners from the top flange, remove only the center 2 fasteners, which hold the drive and extended options cabinet together. The outer fasteners continue to support the extended options cabinet after the drive has been removed.

Disassembly

1. Remove the input, output, and brake (if present) busbars in accordance with *chapter 11.3.2 Accessing the Heat Sink Fan in D7h/D8h Drives*.
2. Remove the ground bracket by removing 2 nuts (17 mm) from the ground studs on the left side of the plate, 1 screw (T25) from the center, and 2 nuts (8 mm) from the bottom.
3. Remove 6 nuts (8 mm) inside the option cabinet on the bottom of the 3 brackets between the option cabinet and the main enclosure.
4. Remove 2 connector plates on the top of the drive by removing 8 screws (T25), 4 from each plate.
5. Lift the drive away from the extended options cabinet.

Reassembly

Reinstall in reverse order of this procedure. Tighten hardware according to *chapter 14.1 Fastener Torque Ratings*.

11.3.2 Accessing the Heat Sink Fan in D7h/D8h Drives

Disassembly

The D7h and D8h drives include an extended options cabinet mounted below the main enclosure. To access the heat sink fan in D7h/D8h drives, remove the busbars between the main enclosure and the extended options cabinet using the following steps. In drives with different option configurations, the busbars can vary slightly from the busbars pictured.

1. Remove the air baffle covering the interior components.
2. Remove the EMC shield by removing 2 screws (T25).
3. Remove the 3 mains input jumper busbars between the main enclosure and the extended options cabinet. See *Illustration 11.37*:
 - 3a Remove 3 screws (17 mm) from the top of the mains input jumper busbars, 1 per busbar.
 - 3b Remove 3 nuts (13 mm) from the bottom of the mains input jumper busbars, 1 per busbar.

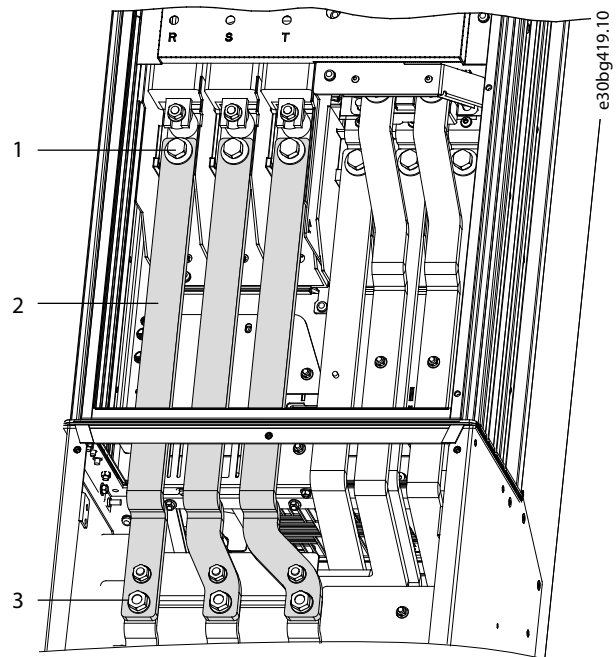

1	Screw (17 mm)
2	Mains input jumper busbars
3	Nut (13 mm)

Illustration 11.37 Mains Input Jumper Busbars in D7h/D8h

4. If the brake/regen option is present, remove the 2 brake jumper busbars between the main enclosure and the extended options cabinet. See *Illustration 11.38*:

- 4a Remove 2 nuts (8 mm) attaching the brake jumper busbars to the standoffs, 1 per busbar.
- 4b Remove 2 nuts (17 mm) from the lower end of the brake jumper busbars, 1 per busbar.
- 4c Remove 2 screws (17 mm) from the top end of the brake jumper busbars, 1 per busbar.

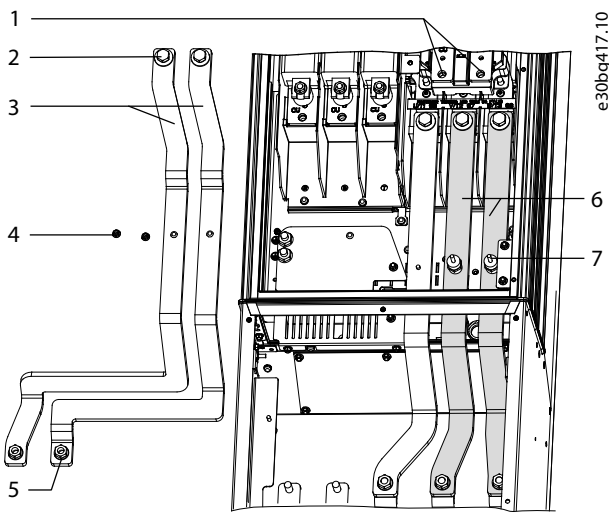

1	Brake terminals
2	Screw (17 mm)
3	Brake jumper busbars
4	Nut (8 mm) for standoff
5	Nut (17 mm)
6	Motor busbars (V and W)
7	Standoff

Illustration 11.38 Brake/Regen Jumper Busbars in D7h/D8h

5. Remove the 3 motor output jumper busbars between the main enclosure and the extended options cabinet. See *Illustration 11.39*:

- 5a Remove 3 nuts (17 mm) at the bottom of the motor output busbars, 1 per busbar.
- 5b Remove 3 screws (17 mm) from the top of the motor output busbars, 1 per busbar.

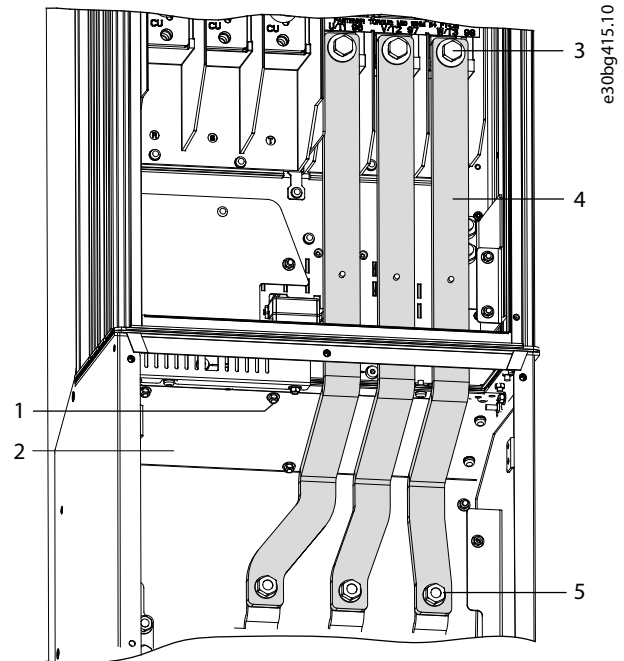

1	Nut (8 mm)
2	Fan access panel
3	Screw (17 mm)
4	Motor output jumper busbars
5	Nut (13 mm)

Illustration 11.39 Motor Output Jumper Busbars in D7h/D8h

- 6. Access the heat sink fan cover by removing 6 nuts (8 mm) from the heat sink fan access panel.
- 7. Lift the heat sink fan access panel from the extended options cabinet.
- 8. Remove the heat sink fan. Refer to *chapter 11.2.25 Heat Sink Fan*.

Reassembly

Reinstall in reverse order of this procedure. Tighten hardware according to *chapter 14.1 Fastener Torque Ratings*.

11.3.3 Contactor

To remove or reinstall the contactor, use the following steps. Refer to *Illustration 11.40*.

Disassembly

1. Remove the input busbars in accordance with *chapter 11.3.2 Accessing the Heat Sink Fan in D7h/D8h Drives*.
2. Remove the fuses (not shown) by removing 3 nuts (17 mm) from above the fuses and 3 screws (17 mm) from below the fuses.
3. Remove the contactor to fuse busbars by removing 3 nuts (17 mm).
4. Remove the contactor coil wires from terminals A1 and A2.
5. Remove 4 bolts (13 mm) from the contactor bracket and lift out the contactor.

Reassembly

Reinstall in reverse order of this procedure. Tighten hardware according to *chapter 14.1 Fastener Torque Ratings*.

11.3.4 Disconnect

To remove or reinstall the disconnect, use the following steps. Refer to *Illustration 11.40*.

Disassembly

1. Remove the fuses in accordance with *chapter 11.3.3 Contactor*.
2. Remove 4 screws (T25), 1 from each corner of the disconnect.
3. Remove the disconnect by pulling it downward and out of the cabinet.

Reassembly

Reinstall in reverse order of this procedure. Tighten hardware according to *chapter 14.1 Fastener Torque Ratings*.

130BF846.10

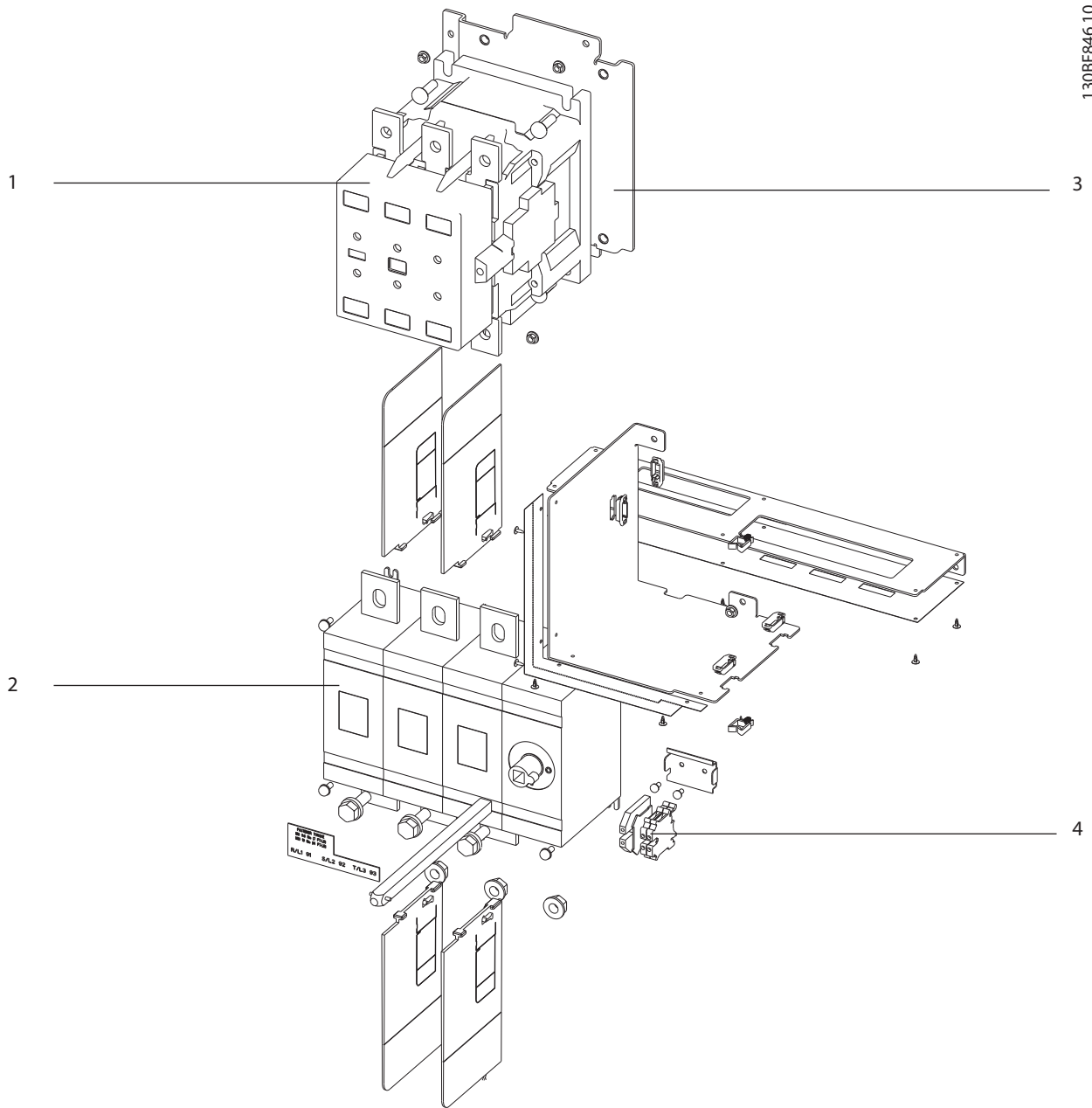

11

1	Contactor	3	A1/A2 contactor coil terminals
2	Disconnect	4	Contacteur bracket

Illustration 11.40 Contactor and Disconnect

11.4 Heat Sink Access Panel

11.4.1 Removing the Heat Sink Access Panel

The drive has an optional access panel for accessing the heat sink. To remove or reinstall the heat sink access panel, use the following steps. Refer to *Illustration 11.41*.

Disassembly

1. Do not power the drive while removing the heat sink access panel.
2. If the drive is mounted on a wall, or its back is otherwise inaccessible, reposition it to provide full access.
3. Remove the internal hex screws (3 mm) connecting the access panel to the back of the enclosure. There are 5 or 9 screws depending on the size of the drive.

Reassembly

Tighten fasteners according to *chapter 14.1 Fastener Torque Ratings*.

1. Do not power the drive while removing the heat sink access panel.
2. If the drive is mounted on a wall, or its back is otherwise inaccessible, reposition it to provide full access.
3. Fasten the internal hex screws (3 mm) connecting the access panel to the back of the enclosure. There are 5 or 9 screws depending on the size of the drive.

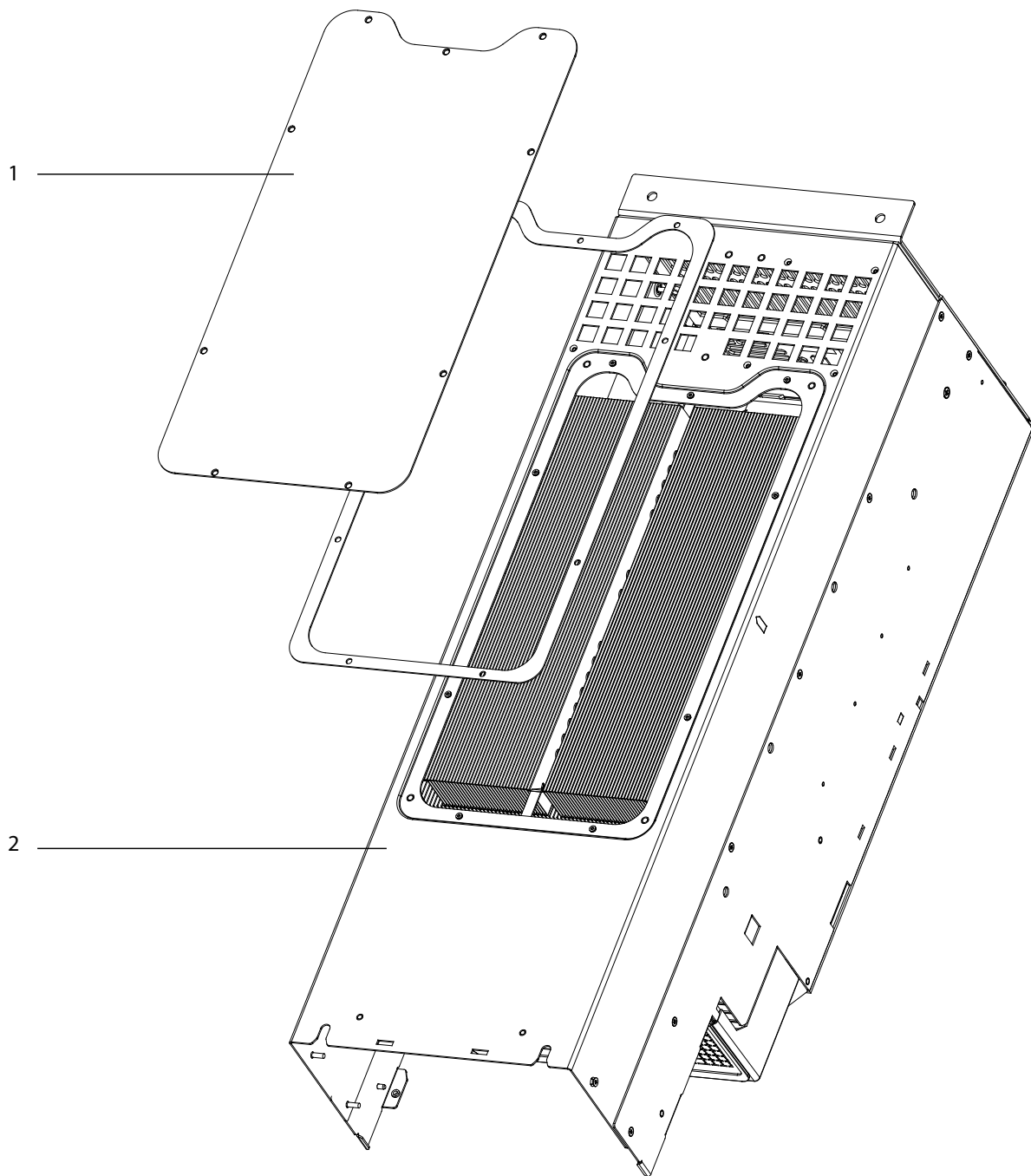

1	Heat sink access panel	2	Drive enclosure
---	------------------------	---	-----------------

Illustration 11.41 Heat Sink Access Panel

12 Da2/Db2/Da4/Db4 Parallel System Disassembly and Assembly

12.1 Before Proceeding

Review all safety warnings and cautions in *chapter 2 Safety*.

- DO NOT touch electrical parts of the drive when connected to mains. Also make sure that other voltage inputs have been disconnected (linkage of DC intermediate circuit). There can be high voltage on the DC-link even when the indicator lights are turned off. Before touching any potentially live parts of the drive, wait at least 40 minutes.
- Before conducting repair or inspection, disconnect mains.
- [Off] on the LCP does not disconnect mains.
- During operation and while programming parameters, the motor can start without warning. Press [Stop] when changing data.
- When operating on a PM motor, disconnect the motor cable.

⚠ WARNING DISCHARGE TIME

The drive contains DC-link capacitors, which can remain charged even when the drive is not powered. High voltage can be present even when the warning LED indicator lights are off. Failure to wait the specified time after power has been removed before performing service or repair work can result in death or serious injury.

- Stop the motor.
- Disconnect AC mains and remote DC-link power supplies, including battery back-ups, UPS, and DC-link connections to other drives.
- Disconnect or lock the motor.
- Disconnect any brake option.
- Disconnect any regen/load share option.
- Wait for the capacitors to discharge fully. The minimum waiting time is specified in the following discharge time table and is also visible on the drive label.
- Before performing any service or repair work, use an appropriate voltage measuring device to make sure that the capacitors are fully discharged. For parallel drive modules, measure DC-bus capacitor voltages before and after the individual DC fuses.

Enclosure Size	Minimum waiting time
D1h–D8h drives	20 minutes
J8–J9 drives	20 minutes
D9h–D10h enclosed drive systems	20 minutes
Da2/Da4/Db2/Db4 parallel drive systems	20 minutes
E1h–E4h drives	40 minutes
E5h–E6h enclosed drive systems	40 minutes

Table 12.1 Discharge Time

⚠ WARNING

SHOCK HAZARD

The following options are powered before the optional circuit breaker or disconnect. Even with the circuit breaker or disconnect in the OFF position, mains voltage is still present inside the drive enclosure.

Failure to turn off the main service line/power to the drive before working on the following options can result in death or serious injury:

- Door interlock
- Space heater
- Cabinet light and outlet
- RCD monitor
- IRM monitor
- Emergency stop
- 24 V DC customer supply

NOTICE

INTERLOCKED DOORS

If supplied with a circuit breaker or disconnect switch, the cabinet doors are interlocked. To open the cabinet doors, set the circuit breaker and disconnect switch to the OFF position.

NOTICE

ELECTROSTATIC DISCHARGE (ESD)

Many electronic components within the drive are sensitive to static electricity. Voltages so low that they cannot be felt, seen, or heard can be harmful to electronic components. Use standard ESD protective procedures whenever handling ESD sensitive components. Failure to conform to standard ESD procedures can reduce component life, diminish performance, or completely destroy sensitive electronic components.

NOTICE**ENCLOSURE SIZE**

Enclosure size designations are used throughout this guide where procedures or components differ between drives based on size. Refer to *chapter 3.4 Enclosure Size Identification* and *chapter 3.5 Enclosure Size Definitions* in determining enclosure size.

12.1.1 Lifting the Unit

For dimensions and center of gravity, see the *VLT® Parallel Drive Modules Installation Guide*.

- Ensure that the lifting device is suitable for the task.
- Move the unit using a hoist, crane, or forklift with the appropriate rating.
- Always use the dedicated lifting eye bolts. See *Illustration 12.1*.

CAUTION**HEAVY LOAD**

Unbalanced loads can fall and loads can tip over. Failure to take proper lifting precautions increases risk of death, serious injury, or equipment damage.

- Never walk under suspended loads.
- To guard against injury, wear personal protective equipment such as gloves, safety glasses, and safety shoes.
- Be sure to use lifting devices with the appropriate weight rating. The lifting bar must be able to handle the weight of the load.
- The load's center of gravity can be in an unexpected location. Failure to locate the center of gravity and correctly position the load before lifting can cause unexpected shifting during lifting and transport.
- The angle from the top of the drive module to the lifting cables has an impact on the maximum load force on the cable. This angle must be 65° or greater. Refer to *Illustration 12.1*. Attach and dimension the lifting cables properly.

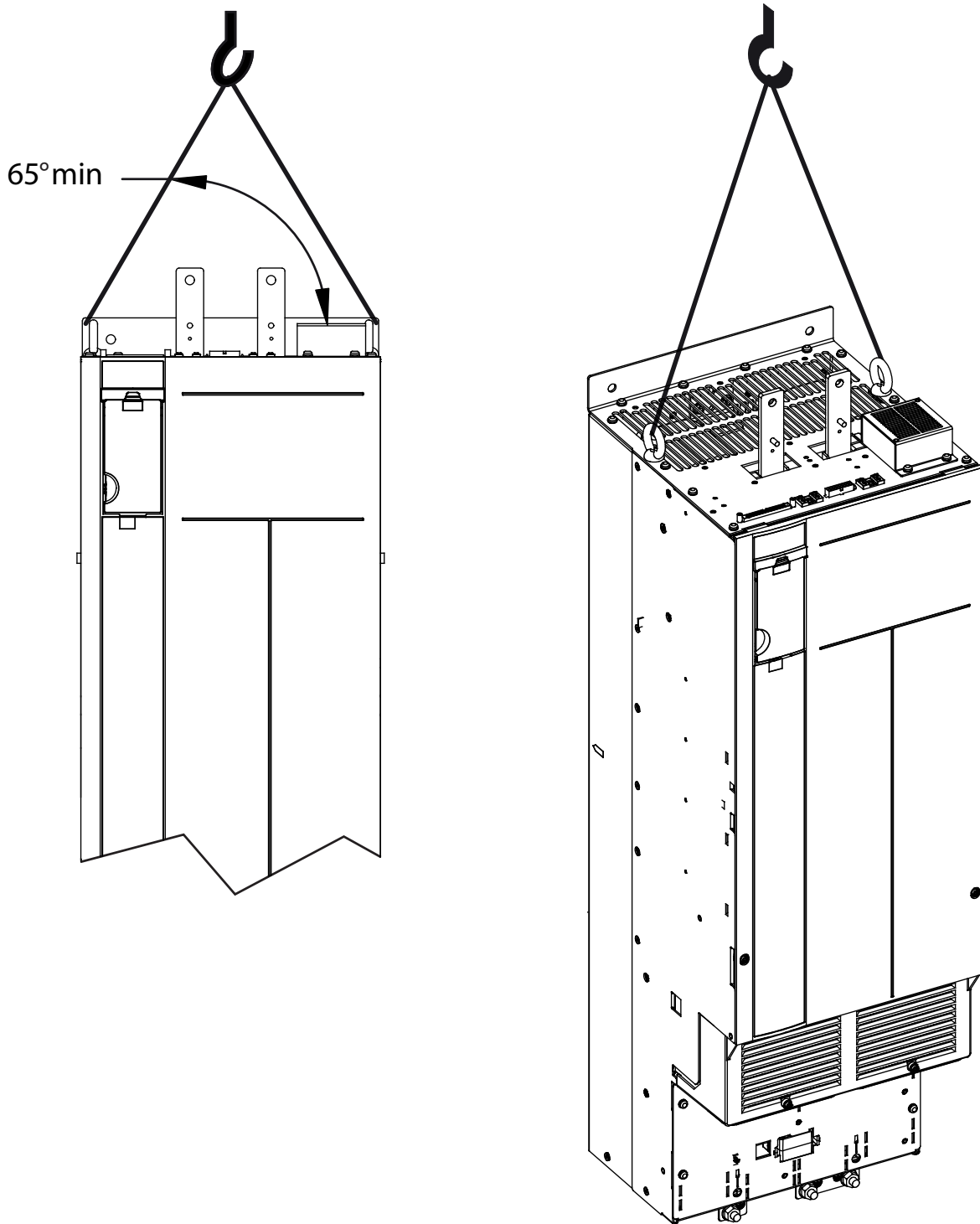

12

Illustration 12.1 Lifting the Drive Module

12.2 Parallel Drive System Disassembly and Assembly

12.2.1 Removing the Control Shelf

To remove the control shelf assembly, use the following steps. See *Illustration 12.2*.

1. Disconnect the relay cable from the corresponding relay connector on the top of the drive module.
2. Disconnect the 44-pin ribbon cables from the MDCIC plug on the top of the drive module.
3. If the drive module has an external LCP, disconnect the LCP cable from the connector on the control shelf.
4. Unfasten the mounting bracket and remove the control shelf assembly.
5. Place the control shelf assembly in an ESD-protected package.

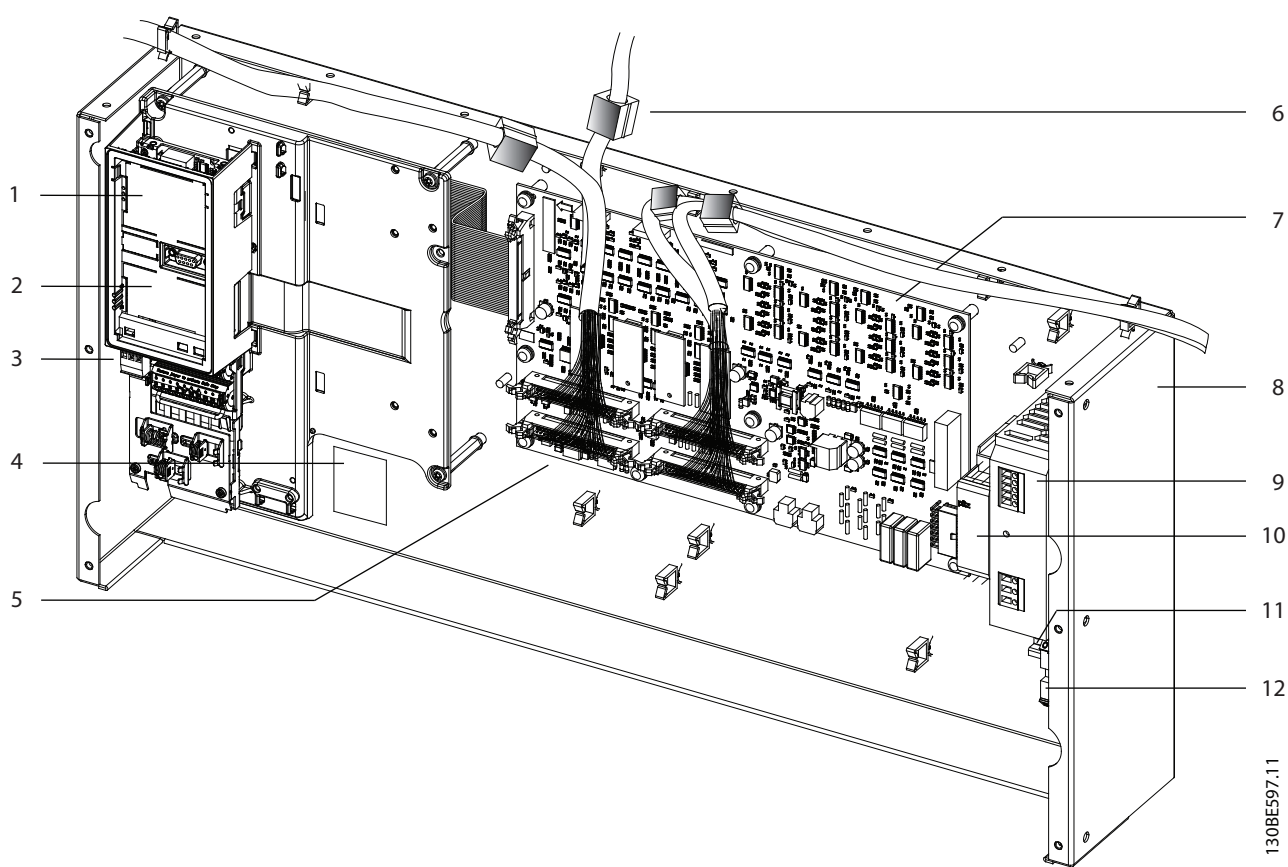

1	LCP cradle	7	Multi-drive control interface card (MDCIC)
2	Control card (underneath LCP cradle)	8	Control shelf
3	Control terminal blocks	9	Switched mode power supply (SMPS)
4	Product label	10	Pilz relay
5	44-pin cables from MDCIC to drive modules	11	DIN rail
6	Ferrite core	12	Terminal block mounted on DIN rail

Illustration 12.2 Control Shelf Disassembly for a 4-module System

12.2.2 Removing a Drive Module

To remove a drive module from the cabinet enclosure, use the following steps.

1. Remove busbars, wiring connections, shielding, or other components blocking access to the drive module. See *Illustration 12.3*.

NOTICE

Because drive module systems can be customized, the components that must be removed to allow access can vary.

2. Install 2 eye bolts in the top of the drive module and attach a hoist with an appropriate lifting harness. Alternatively, support the drive module from below the unit with a lift or jack.
3. Remove 2 M10 screws from each DC fuse on the top of the drive module.
4. Remove 2 DC fuses and microswitches. Refer to *Illustration 3.7*.
5. Remove 2 nuts at the bottom of the unit, unfastening it from the mounting panel. See *Illustration 12.3*.
6. Remove the M10x26 screws from the top of the unit, unfastening it from the top of the mounting panel.
7. Using the proper lifting equipment, lift the drive module from the cabinet enclosure.

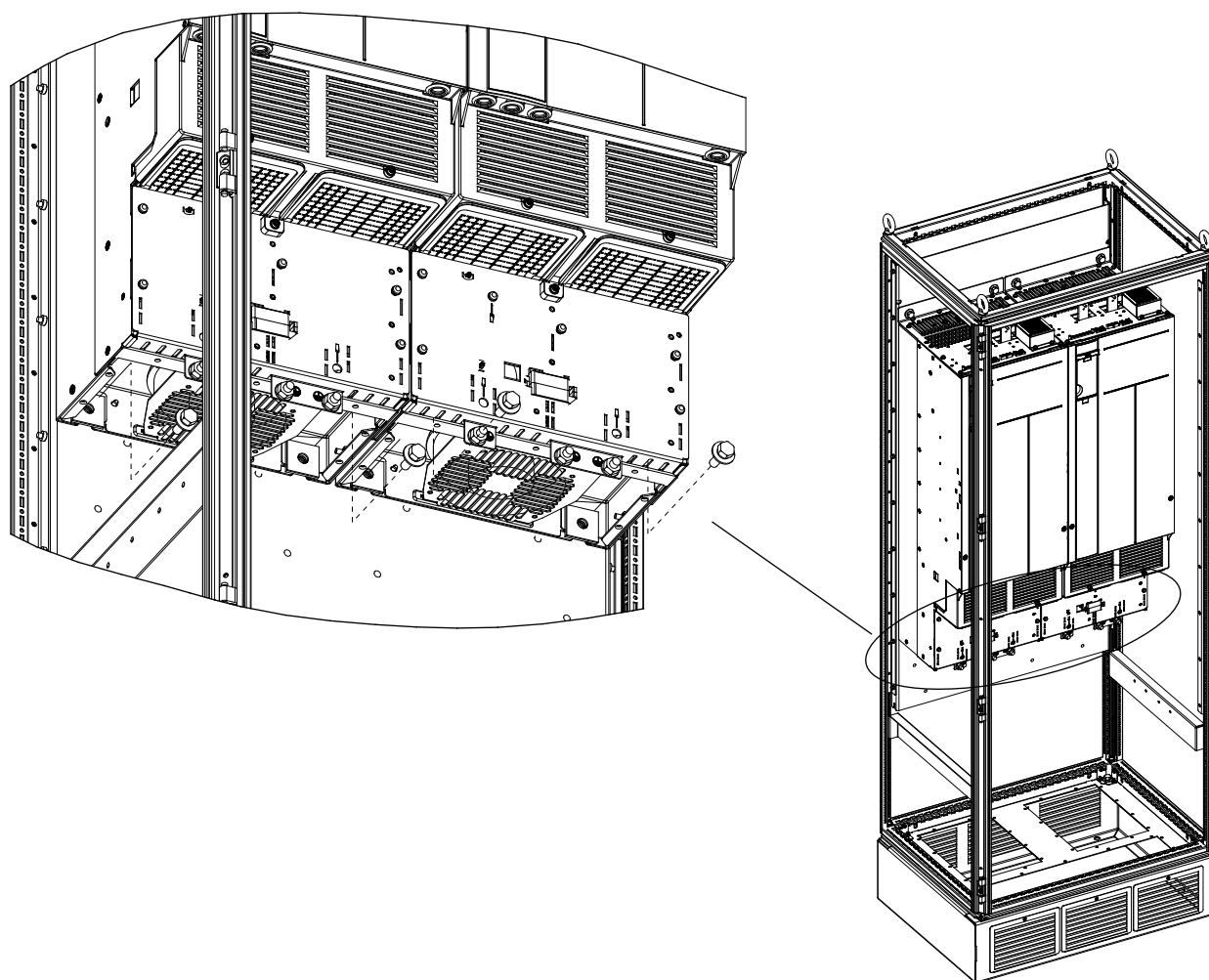

130BE572.10

12

Illustration 12.3 Removal of Bottom Mounting Bolts

12.2.3 Installing the Drive Modules

Install the drive modules into the cabinet enclosure as described in the following steps.

1. Unpack the drive modules from the packaging.
2. Install 2 eye bolts in the top of the first drive module. Prepare the drive module for lifting, using an appropriate lifting harness and an overhead hoist or crane with the necessary lifting capacity.

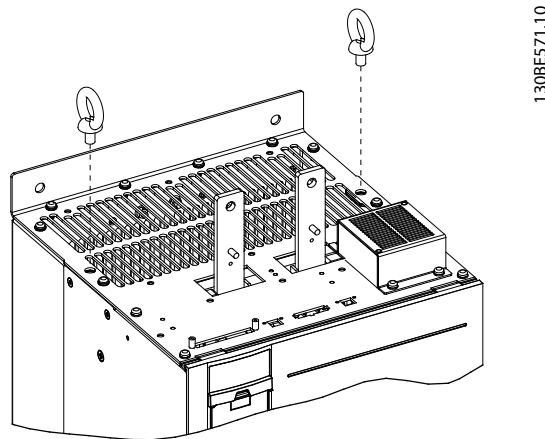
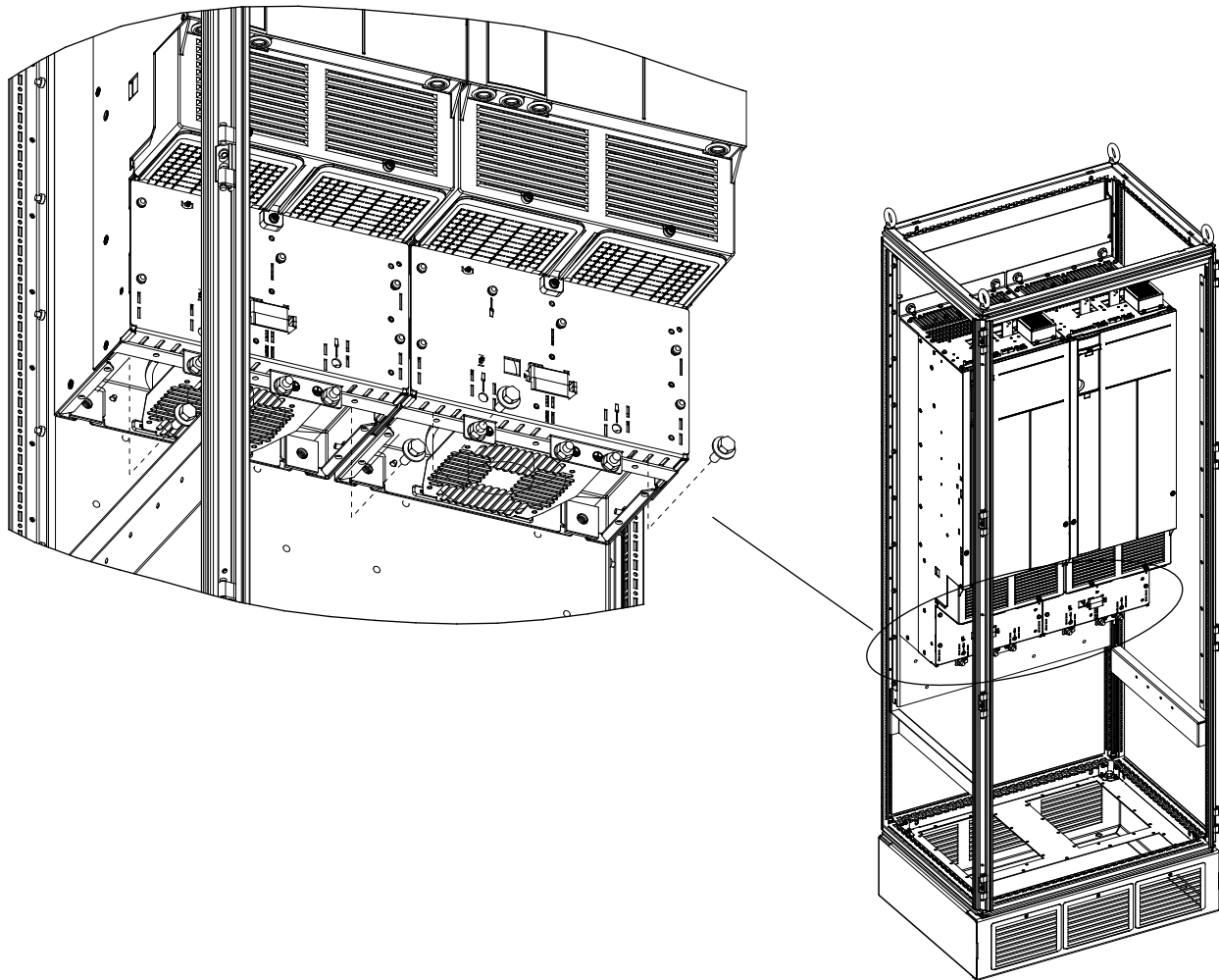

Illustration 12.4 Installation of Eye Bolts

3. Install the 2 bottom screws and gaskets onto the mounting panel.
4. Using the crane or hoist, lift the drive module and then lower the unit through the top of the cabinet enclosure. Align the bottom mounting holes of the unit with the 2 bottom screws on the mounting panel.
5. Check that the drive module is aligned correctly on the mounting panel. Secure the bottom of the unit to the panel with 2 nuts. See *Illustration 12.3*. Torque the hex nuts. Refer to *chapter 14.1 Fastener Torque Ratings*.
6. Secure the top of the unit to the mounting panel with M10x26 screws, and then torque the screws.
7. Line up the groove on the microswitch with the edges on each DC fuse and press firmly until the microswitch clicks into place.
8. Install 2 DC fuses onto the tops of the DC-link terminals on each drive module.
9. Install the microswitches on the outer side of each DC-link terminal. Refer to *Illustration 3.7*.
10. Secure each fuse with 2 M10 screws and torque the screws.
11. Install the next drive module.



130BE572.10

12

Illustration 12.5 Installation of Bottom Mounting Bolts

12.2.4 Installing the Control Shelf

NOTICE

To avoid RFI, do not route control wiring together with power cables or busbars.

1. Remove the control shelf assembly from its package.
2. Remove the LCP from the control shelf.
3. Use some type of mounting hardware to install the control shelf. Danfoss does not supply the mounting brackets for the control shelf. For correct EMC installation, refer to *Illustration 12.6*.
4. Remove the MDCIC cover from the control shelf assembly.
5. Connect the 44-pin ribbon cables from the MDCIC card to the top of the drive modules. The numbers next to the connectors on the MDCIC reflect the number of the module.
6. Route the 44-pin ribbon cables inside the cabinet.
7. Connect the external brake fault wiring harness between the microswitch terminals and the brake jumper connector on the top of the drive module.
8. Connect the relay wiring between relay 1 or 2 on the control shelf and the corresponding relay connector on the top of the drive module.
9. Connect the second jumper to the corresponding brake jumper connector on the top of the drive module.

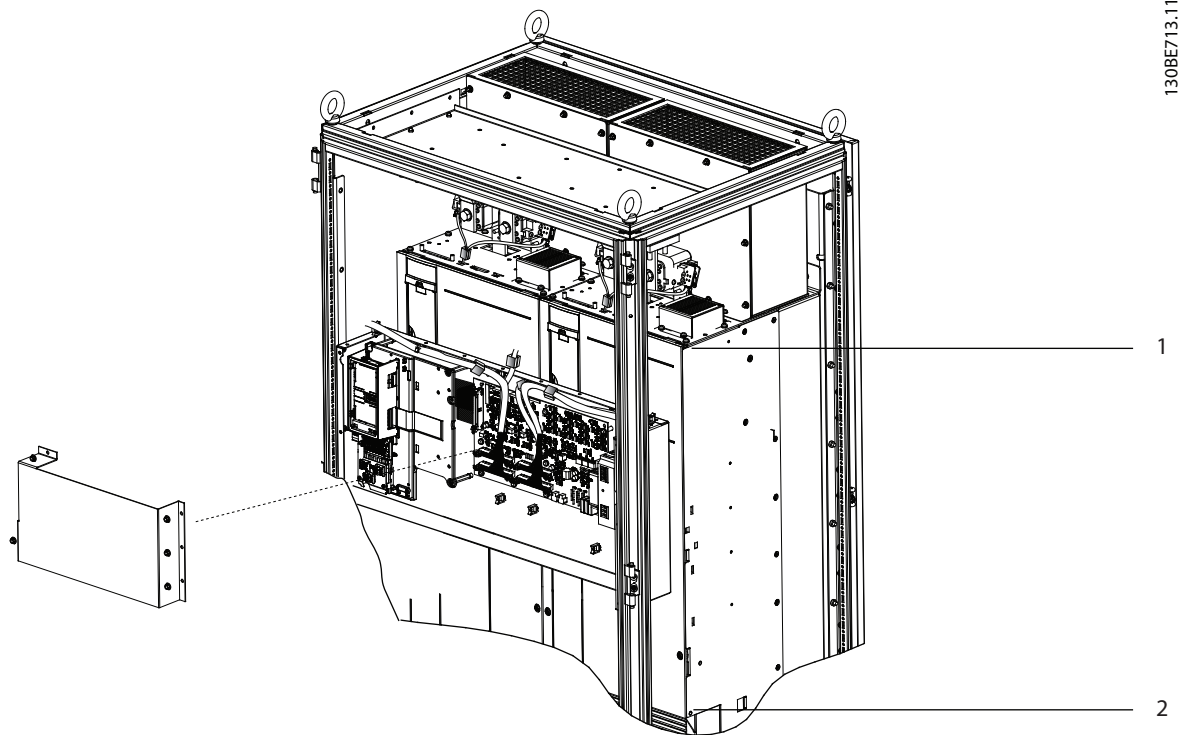

1	Control shelf must stay below this point	2	Control shelf must stay above this point
---	--	---	--

Illustration 12.6 Positioning the Control Shelf for Correct EMC Installation

12.3 Parallel Drive Module Disassembly and Assembly

12.3.1 General Information

The instructions in this chapter include procedures for disassembly of parallel drive systems in IP00 enclosures. The parallel drive modules within the systems are similar to the D3h/D4h drives described in previous chapters. Instead of an individual control card, the VLT® Parallel Drive Modules have a blank mounting plate and are controlled by the MDCIC. The disassembly of the blank mounting plate is described in this chapter. For other disassembly procedures, refer to *Table 12.2*.

Parallel drive system	Parallel drive module disassembly instructions
Da2 system	Refer to <i>chapter 10 D1h/D3h/D5h/D6h/J8 Drive Disassembly and Assembly</i> .
Da4 system	Refer to <i>chapter 10 D1h/D3h/D5h/D6h/J8 Drive Disassembly and Assembly</i> .
Db2 system	Refer to <i>chapter 11 D2h/D4h/D7h/D8h/J9 Unit Disassembly and Assembly</i> .
Db4 system	Refer to <i>chapter 11 D2h/D4h/D7h/D8h/J9 Unit Disassembly and Assembly</i> .

Table 12.2 Additional Disassembly Instructions

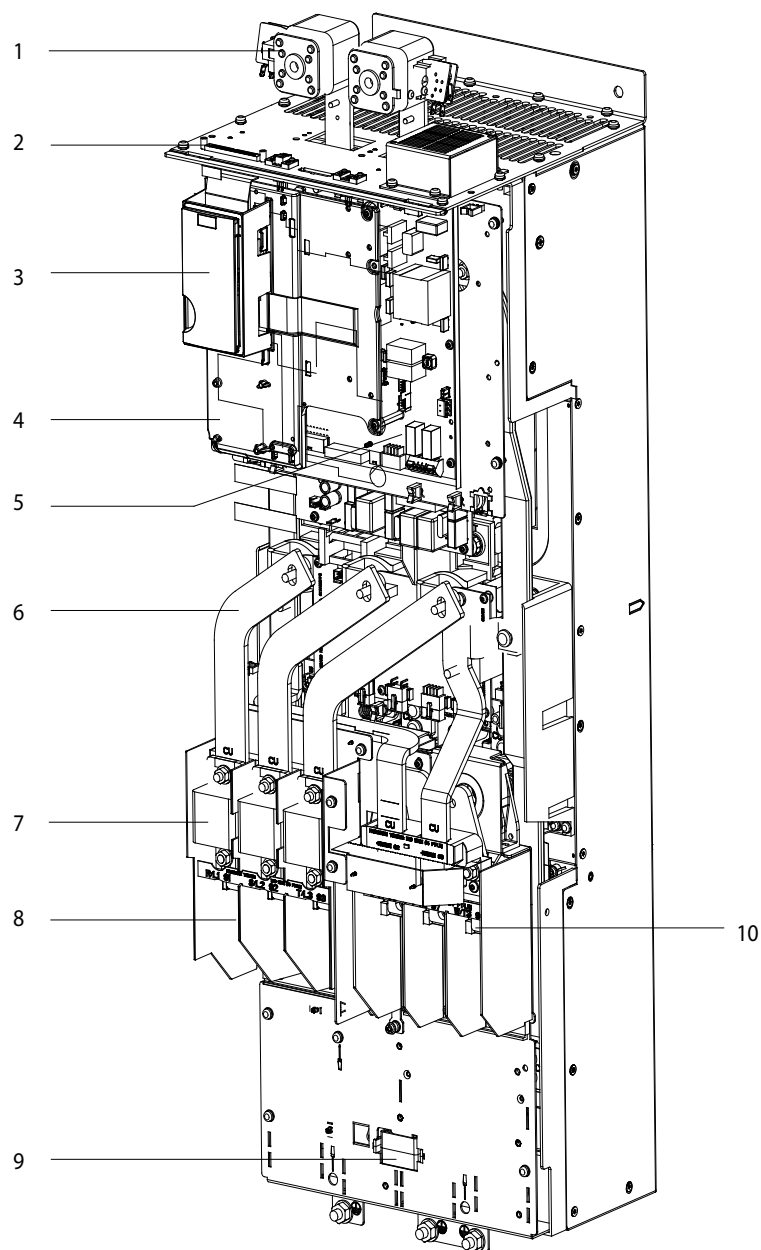

12

1	DC fuse and microswitch	6	AC input busbars
2	44-pin connector for cable from MDCIC	7	AC fuses
3	Blank cover plate (no LCP)	8	Mains terminals to drive module
4	Blank mounting plate (no control card)	9	Mixing fan
5	Power card	10	Output terminals to motor

Illustration 12.7 Parallel Drive Module

12.3.2 Blank Mounting Plate

NOTICE**PARTS CONFIGURATION**

In VLT® Parallel Drive Modules, the mounting plate is blank and does not hold a control card. In parallel drive systems, the control card is found on the system control shelf, not in the individual modules.

To remove or replace the blank mounting plate, use the following steps. Refer to *Illustration 12.8*.

Disassembly

1. Remove the front cover of the parallel drive module.
2. Remove the blank LCP cover. The cover can be removed by hand.
3. Remove 4 screws (T20), 1 from each corner of the blank mounting plate.

Reassembly

Tighten fasteners according to *chapter 14.1 Fastener Torque Ratings*.

1. Position the blank mounting plate in the unit.
2. Secure 4 screws (T20), 1 in each corner of the blank mounting plate.
3. Replace the blank LCP cover. The cover can be replaced by hand.
4. Replace the front cover of the drive module.

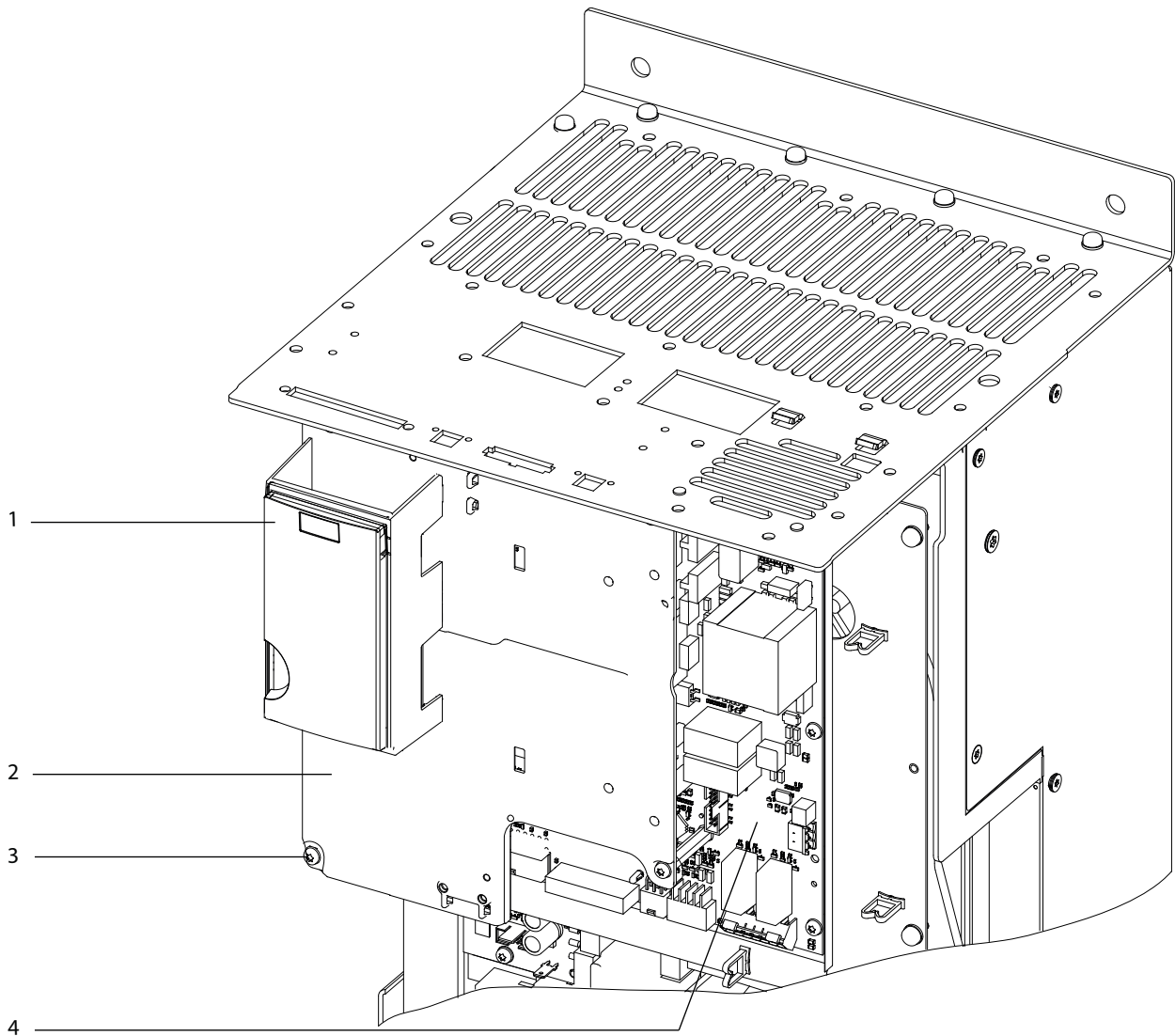

12

1	Blank LCP cover	3	Screw (T25)
2	Blank mounting plate	4	Power card

Illustration 12.8 Blank Mounting Plate

13 E1h–E4h Drive Disassembly and Assembly

13.1 Before Proceeding

Review all safety warnings and cautions in *chapter 2 Safety*.

- DO NOT touch electrical parts of the drive when connected to mains. Also make sure that other voltage inputs have been disconnected (linkage of DC intermediate circuit). There can be high voltage on the DC-link even when the indicator lights are turned off. Before touching any potentially live parts of the drive, wait at least 40 minutes.
- Before conducting repair or inspection, disconnect mains.
- [Off] on the LCP does not disconnect mains.
- During operation and while programming parameters, the motor can start without warning. Press [Stop] when changing data.
- When operating on a PM motor, disconnect the motor cable.

⚠ WARNING

DISCHARGE TIME

The drive contains DC-link capacitors, which can remain charged even when the drive is not powered. High voltage can be present even when the warning LED indicator lights are off. Failure to wait the specified time after power has been removed before performing service or repair work can result in death or serious injury.

- Stop the motor.
- Disconnect AC mains and remote DC-link power supplies, including battery back-ups, UPS, and DC-link connections to other drives.
- Disconnect or lock the motor.
- Disconnect any brake option.
- Disconnect any regen/load share option.
- Wait for the capacitors to discharge fully. The minimum waiting time is specified in the following discharge time table and is also visible on the drive label.
- Before performing any service or repair work, use an appropriate voltage measuring device to make sure that the capacitors are fully discharged. For parallel drive modules, measure DC-bus capacitor voltages before and after the individual DC fuses.

Enclosure Size	Minimum waiting time
D1h–D8h drives	20 minutes
J8–J9 drives	20 minutes
D9h–D10h enclosed drive systems	20 minutes
Da2/Da4/Db2/Db4 parallel drive systems	20 minutes
E1h–E4h drives	40 minutes
E5h–E6h enclosed drive systems	40 minutes

Table 13.1 Discharge Time

⚠ WARNING

SHOCK HAZARD

The following options are powered before the optional circuit breaker or disconnect. Even with the circuit breaker or disconnect in the OFF position, mains voltage is still present inside the drive enclosure.

Failure to turn off the main service line/power to the drive before working on the following options can result in death or serious injury:

- Door interlock
- Space heater
- Cabinet light and outlet
- RCD monitor
- IRM monitor
- Emergency stop
- 24 V DC customer supply

NOTICE

INTERLOCKED DOORS

If supplied with a circuit breaker or disconnect switch, the cabinet doors are interlocked. To open the cabinet doors, set the circuit breaker and disconnect switch to the OFF position.

NOTICE

ELECTROSTATIC DISCHARGE (ESD)

Many electronic components within the drive are sensitive to static electricity. Voltages so low that they cannot be felt, seen, or heard can be harmful to electronic components. Use standard ESD protective procedures whenever handling ESD sensitive components. Failure to conform to standard ESD procedures can reduce component life, diminish performance, or completely destroy sensitive electronic components.

NOTICE**ENCLOSURE SIZE**

Enclosure size designations are used throughout this guide where procedures or components differ between drives based on size. Refer to *chapter 3.4 Enclosure Size Identification* and *chapter 3.5 Enclosure Size Definitions* in determining enclosure size.

13.2 E1h–E4h Disassembly and Assembly

13.2.1 General Information

These disassembly and assembly instructions apply to drives in enclosure sizes E1h–E4h. This chapter contains instructions for disassembly and assembly of E1h–E4h drives. The instructions can be used for E-sized drives and drive modules listed in *Table 13.2*.

Drive model	Description
E1h drive	Standard drive in an IP21/IP54 (Type 1/12) enclosure
E2h drive	Larger standard drive in an IP21/IP54 (Type 1/12) enclosure
E3h drive	Similar to E1h, but IP20/Chassis drive
E4h drive	Similar to E2h, but IP20/Chassis drive
Enclosed drive module	Similar to E3h/E4h, but includes 1 drive module in a E5h/E6h enclosed drive system

Table 13.2 E-sized Drives and Drive Modules

NOTICE**FASTENER VARIATIONS**

The number of fasteners in the following procedures can vary due to the differences between enclosure sizes.

13.2.2 Control Card and Control Card Mounting Plate

The control card does not need to be disassembled before the control card mounting plate is removed from the drive. To remove or replace the control card mounting plate with the card attached, use the following steps. See *Illustration 13.1*.

Disassembly

1. Open the front panel door or remove the front cover, depending on the type of enclosure.
2. In IP21/IP54 units, unplug the LCP cable.
3. Unplug the USB connector, if present.
4. Remove any customer control wiring from the control card and option cards.
5. Remove 4 screws (T20) from the corners of the control card mounting plate.
6. Unplug the ribbon cable connecting the control card and power card. To release the cable, press out on the clasps at each end of the cable connector on the power card.

NOTICE

UNIQUE TORQUE VALUES

Tighten screws (T20) to the non-standard torque value specified in the following steps. Tighten remaining fasteners according to *chapter 14.1 Fastener Torque Ratings*.

Reassembly

1. Attach the ribbon cable connecting the control card to the power card. Click shut the clasps on each end of the cable connector.
2. Secure 4 screws (T20) at the corners of the control card mounting plate. Torque to 2.27 Nm (20.1 lb-in).
3. Reconnect any customer control wiring to the control card and option cards.
4. In IP21/IP54 units, connect the LCP cable.
5. Connect the USB, if present.
6. Reattach the front cover, if present depending on the enclosure.

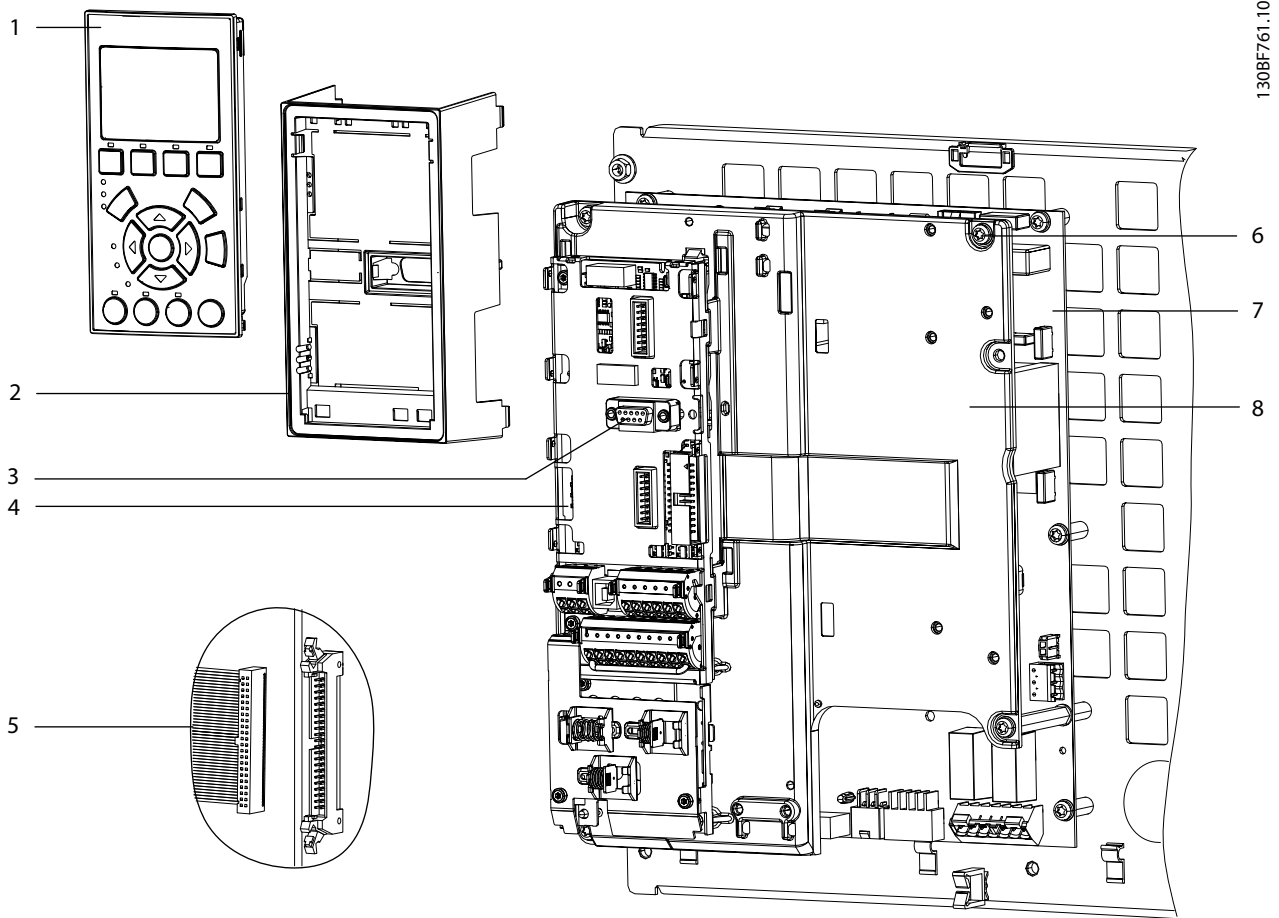

1	LCP	5	Ribbon cable and connector (under control card mounting plate)
2	LCP cradle	6	Screws (T20)
3	LCP cable connector	7	Power card
4	Control card	8	Control card mounting plate

13

Illustration 13.1 LCP and Control Card Mounting Plate

13.2.3 Power Card Mounting Plate

The power card and fan power card do not need to be disassembled when the power card mounting plate is removed from the drive. To remove the power card mounting plate with the cards attached, use the following procedure. To remove the power card from the mounting plate, refer to *chapter 13.2.4 Power Card*. To remove the fan power card from the mounting plate, see *chapter 13.2.5 Fan Power Card*.

NOTICE

The cable that attaches the power card (MK902) and the fan power card (MK803) can remain connected when removing the mounting plate.

Disassembly

1. Remove the control card mounting plate. Refer to *chapter 13.2.2 Control Card and Control Card Mounting Plate*.
2. Disconnect the cables from the following power card connectors:
 - 2a MK101
 - 2b MK103
 - 2c MK105
 - 2d MK501
 - 2e MK502
 - 2f Any additional wiring at MK106 and MK500.
3. Disconnect the following fan power card connectors:
 - 3a MK600
 - 3b MK602
 - 3c MK802
 - 3d MK1200
4. Release the cables from the cable retaining clips.
5. Feed the cable unplugged from MK105/MK1200 through the cable access hole in the mounting plate.
6. Remove 4 nuts (8 mm) from the edges of the mounting plate.
7. Remove 1 screw (T25) from the top center of the mounting plate.

Reassembly

Tighten fasteners according to *chapter 14.1 Fastener Torque Ratings*.

1. Thread the cable unplugged from MK105/MK1200 through the cable access hole to the front of the mounting plate.
2. Replace 1 screw (T25) in the top center of the mounting plate.
3. Fasten 4 nuts (8 mm), 1 in each corner of the power card mounting plate.
4. Reconnect the cables to the following power card connectors:
 - 4a MK101
 - 4b MK103
 - 4c MK105
 - 4d MK501
 - 4e MK502
 - 4f Any additional wiring at MK106 and MK500
5. Reconnect the cables to the following fan power card connectors:
 - 5a MK600
 - 5b MK602
 - 5c MK802
 - 5d MK1200
6. Route the cables through the cable retaining clips on the mounting plate.

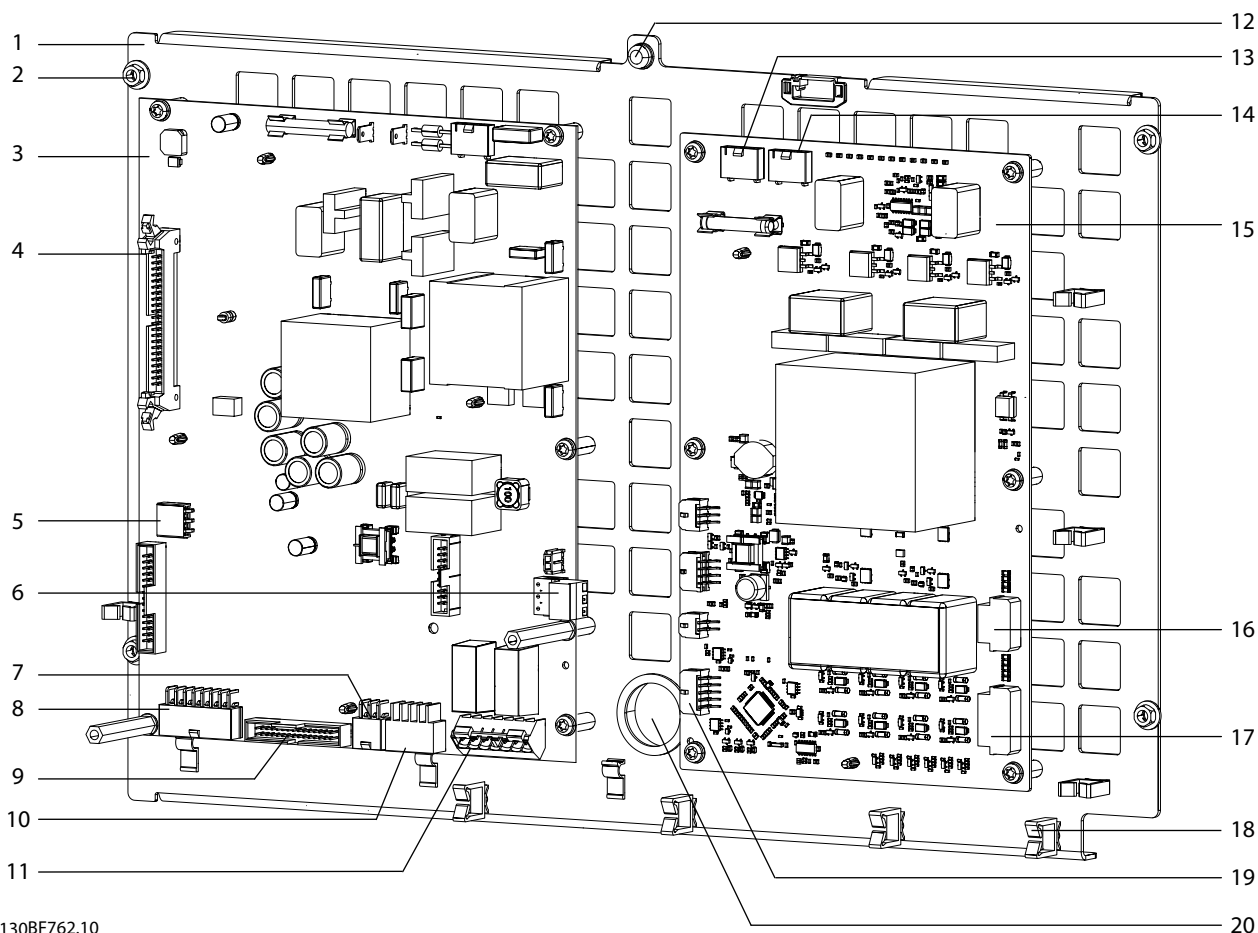

130BF762.10

1	Power card mounting plate	11	MK500 (to customer relays)
2	Nut (8 mm)	12	Center screw (T25)
3	Power card	13	MK803 (to power card)
4	MK102 (to control card)	14	MK802 (to DC power)
5	MK105 (to fan power card and inrush card)	15	Fan power card
6	MK106 (to brake temperature switch)	16	MK602 (to door/top fans)
7	MK502 (to EMC relays)	17	MK600 (to heat sink fans)
8	MK101 (to current sensors)	18	Cable retaining clip
9	MK103 (to gate drive card)	19	MK1200 (CANBUS to inrush card and power card)
10	MK501 (to mixing fans)	20	Cable access hole

Illustration 13.2 Power Card Mounting Plate

13.2.4 Power Card

To remove or reinstall the power card, use the following steps. Refer to *Illustration 13.3*.

NOTICE

PARTS REUSE

A new current scaling card is not included with replacement power cards. Retain the current scaling card so it can be reinstalled on the new power card.

Disassembly

1. Remove the control card mounting plate. Refer to *chapter 13.2.2 Control Card and Control Card Mounting Plate*.
2. Unplug the cables from the following power card connectors:
 - 2a MK101
 - 2b MK103
 - 2c MK105
 - 2d MK501
 - 2e MK502
 - 2f MK902
 - 2g Any additional wiring at MK106 and MK500
3. Remove 5 screws (T20) from the power card.
4. Remove 2 standoffs (7 mm).
5. Remove the power card from the 4 plastic standoffs, pinching the standoffs to compress them.
6. Remove the current scaling card from the power card, pinching the tip of the plastic standoff. To avoid bending the card, lift it parallel to the power card.

NOTICE

UNIQUE TORQUE VALUES

Tighten screws (T20) to the non-standard torque value specified in the following steps. Tighten all other fasteners according to *chapter 14.1 Fastener Torque Ratings*.

Reassembly

1. Insert the current scaling card into the standoff on the new power card. Press the scaling card onto the current scaling card fastener (MK100).
2. Position the power card on the mounting plate, and press it on to the 4 plastic standoffs.
3. Secure 2 metal standoffs (7 mm).
4. Secure 5 screws (T20) in the power card. Torque to 2.27 Nm (20.1 lb-in).
5. Plug the cables into the following power card connectors:
 - 5a MK101
 - 5b MK103
 - 5c MK105
 - 5d MK501
 - 5e MK502
 - 5f MK902
 - 5g Any additional wiring at MK106 and MK500
6. Route the cables through the cable retaining clips.

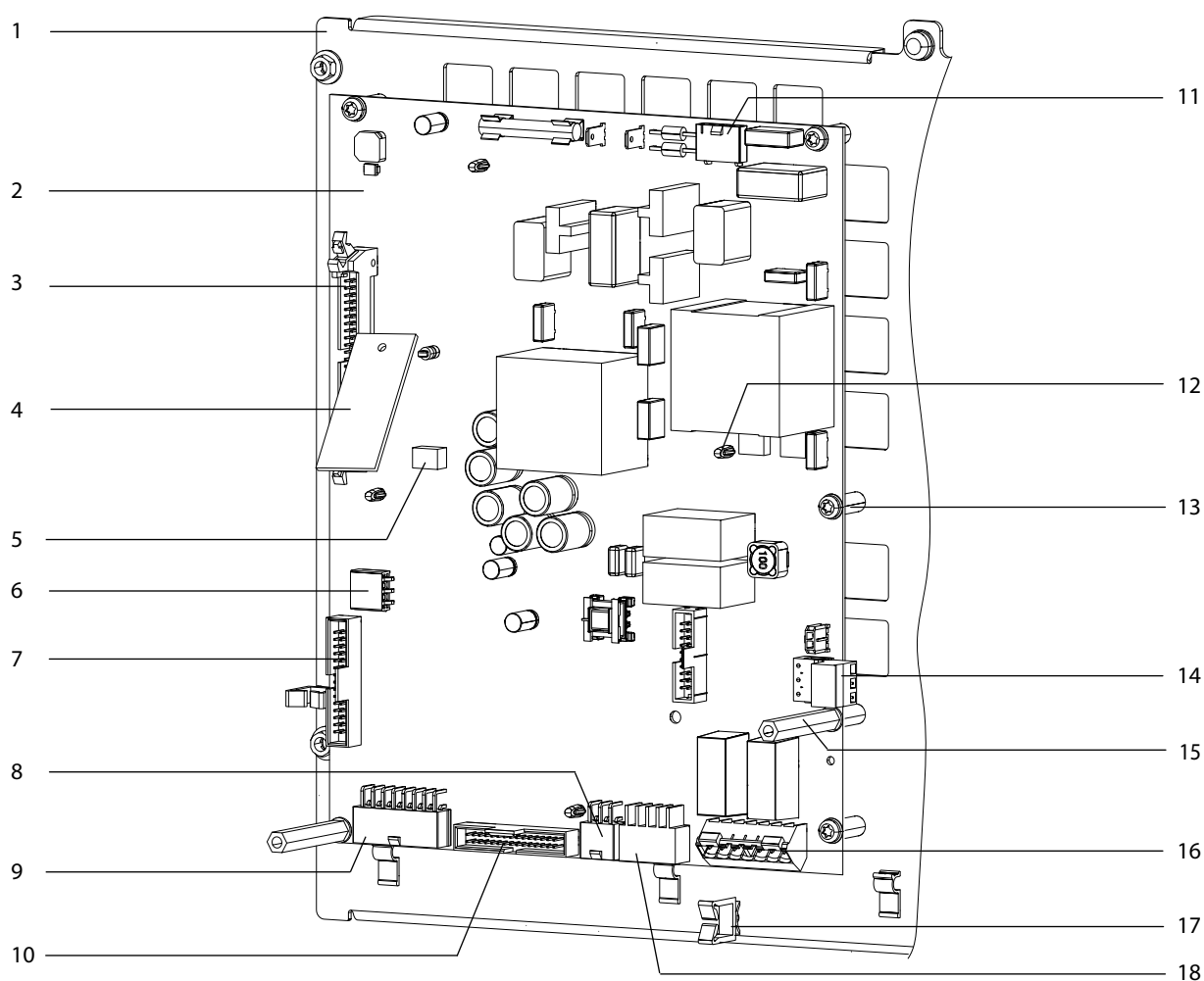

130BF763.10

1	Power card mounting plate	10	MK103 (to gate drive card)
2	Power card	11	MK902 (to fan power card MK803)
3	MK102 (connector to control card ribbon cable)	12	Plastic standoff
4	Current scaling card	13	Screw (T20)
5	MK100 (current scaling card connector)	14	MK106 (to brake temperature switch)
6	MK105 (to fan power card MK1200)	15	Metal standoff (7 mm)
7	MK104 (signal test connector)	16	MK500 (to customer relays)
8	MK502 (to EMC relays)	17	Cable retaining clip
9	MK101 (to current sensors)	18	MK501 (to mixing fans)

Illustration 13.3 Power Card

13.2.5 Fan Power Card

To remove or reinstall the fan power card, use the following steps. Refer to *Illustration 13.4*.

Disassembly

1. Remove the control card mounting plate. Refer to *chapter 13.2.2 Control Card and Control Card Mounting Plate*.
2. Unplug the cables from the following fan power card connectors:
 - 2a MK600
 - 2b MK602
 - 2c MK802
 - 2d MK803
 - 2e MK1200
3. Release the cables from the cable retaining clips.
4. Remove 6 screws (T20).
5. Remove the fan power card from the 4 plastic standoffs, pinching the standoff tips to compress them.
6. Remove the fan power card from the drive.

NOTICE

UNIQUE TORQUE VALUES

Tighten screws (T20) to the non-standard torque value specified in the following steps. Tighten remaining fasteners according to *chapter 14.1 Fastener Torque Ratings*.

Reassembly

1. Position the fan power card on the power card mounting plate, and press onto the 4 plastic standoffs.
2. Fasten 6 screws (T20). Torque to 2.27 Nm (20.1 lb-in).
3. Attach the cables to the following fan power card connectors:
 - 3a MK600
 - 3b MK602
 - 3c MK802
 - 3d MK803
 - 3e MK1200
4. Route the cables through the cable retaining clips on the mounting plate.

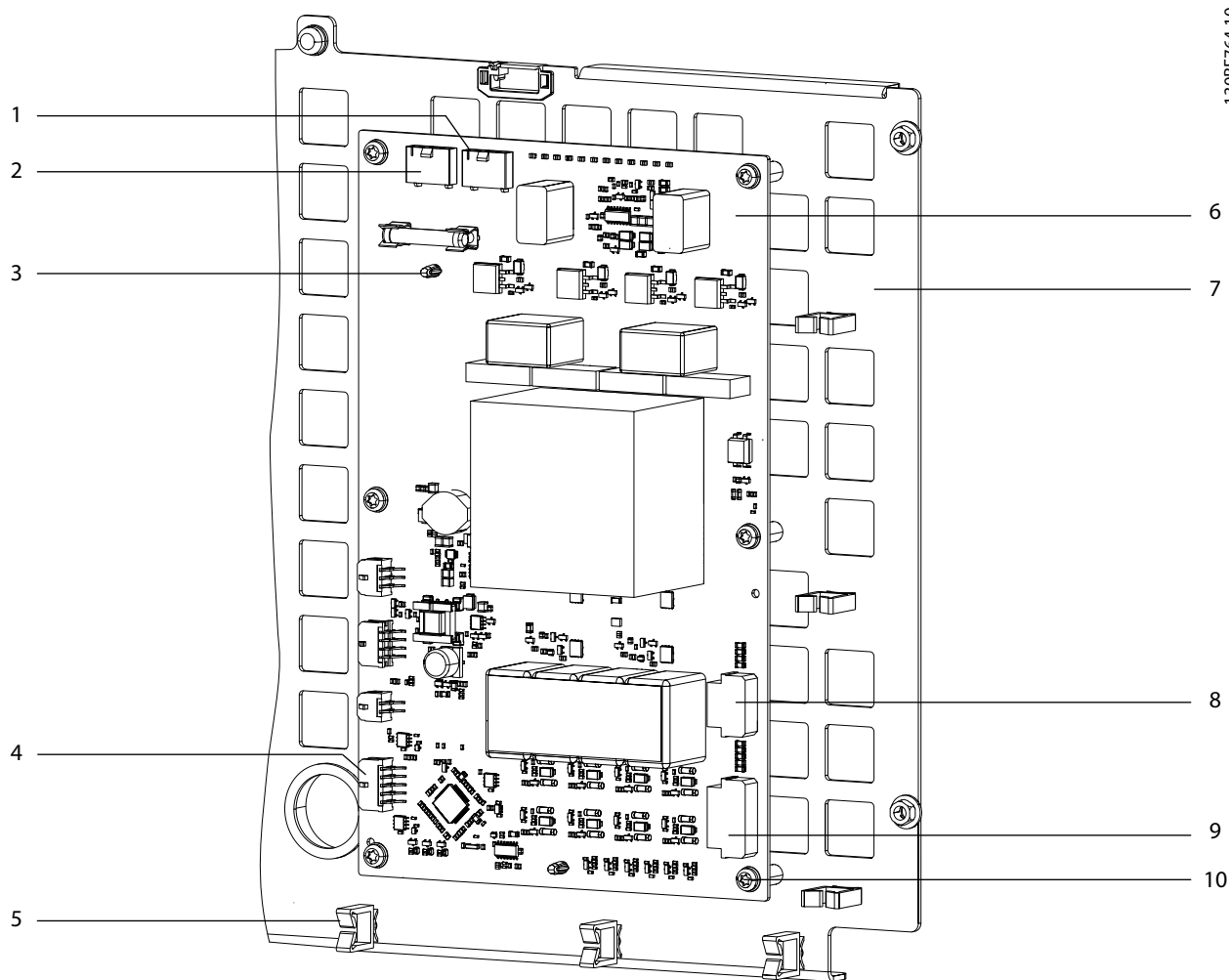

130BF764.10

1	MK802 (to DC power)	6	Fan power card
2	MK803 (to power card MK902)	7	Power card mounting plate
3	Plastic standoff	8	MK602 (to door/top fans)
4	MK1200 (to inrush card and power card MK105)	9	MK600 (to heat sink fans)
5	Cable retaining clip	10	Screw (T20)

Illustration 13.4 Fan Power Card

13.2.6 Inrush Card

To remove or reinstall the inrush card, use the following steps. Refer to *Illustration 13.5*.

NOTICE

PARTS DAMAGE PREVENTION

To avoid damage to the inrush card, do not flex or bend the card during installation or removal.

Disassembly

1. Remove the power card mounting plate. Refer to *chapter 13.2.3 Power Card Mounting Plate*.
2. Unplug the cables from the following inrush card connectors:
 - 2a MK109 (SCR gate)
 - 2b MK110 (CAN bus)
3. Remove 5 screws (T20) from the inrush card.
4. Lift the inrush card upward to release it from the alignment tabs at the bottom edge of the plastic inrush card frame.

Reassembly

Tighten fasteners according to *chapter 14.1 Fastener Torque Ratings*.

1. Position the inrush card in the plastic inrush card frame, placing the card behind the alignment tabs along the bottom edge.
2. Fasten 5 screws (T20) securing the inrush card.
3. Connect the cables to the following inrush card connectors:
 - 3a MK109 (SCR gate)
 - 3b MK110 (CAN bus)
4. Reinstall the power card mounting plate.

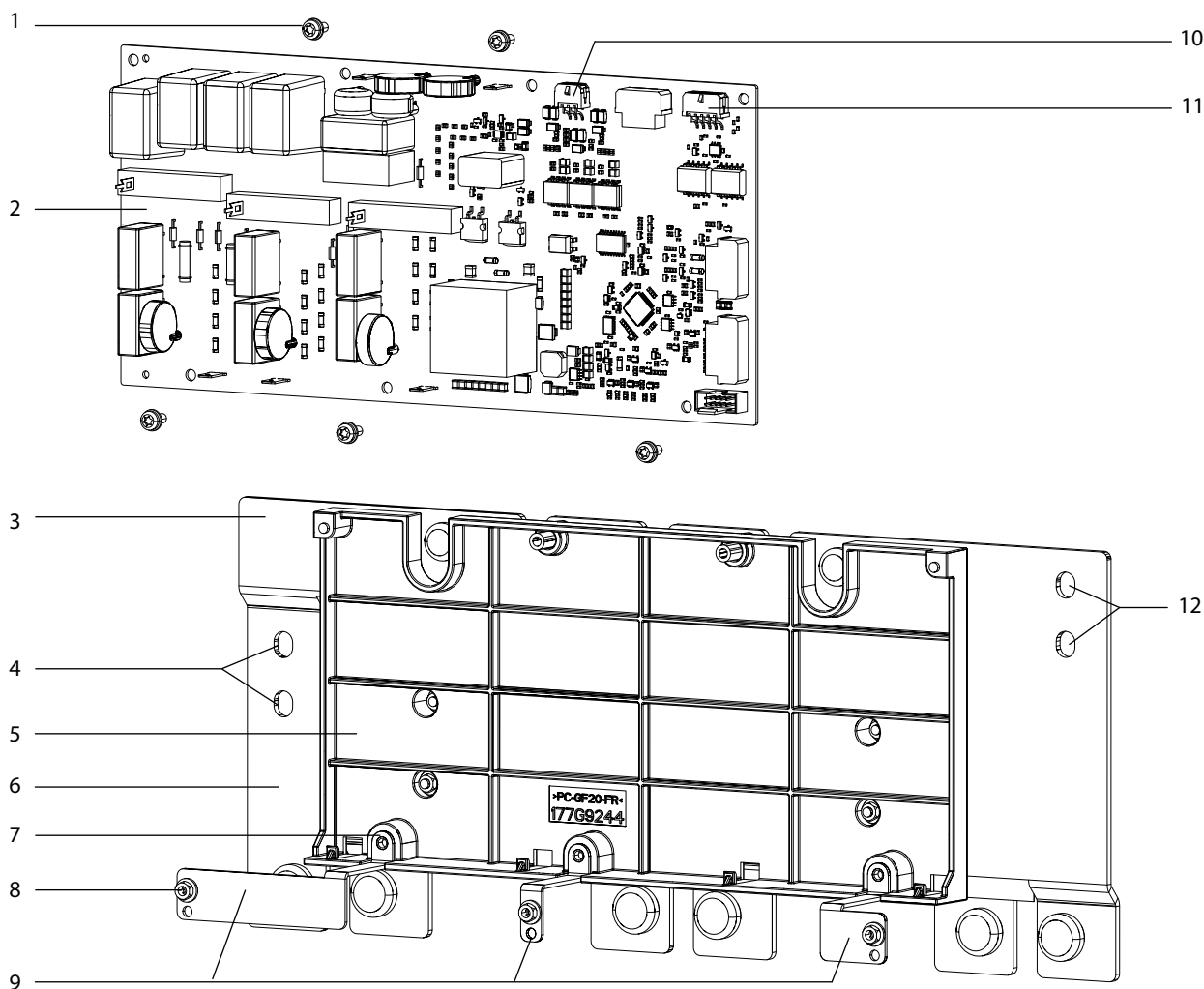

1	Screw (T20)	7	Alignment tab
2	Inrush card	8	Nut (7 mm)
3	Rectifier(+) bus plate	9	Inrush busbars
4	Connection point for load share/regen (optional)	10	MK109: SCR gate
5	Inrush card frame	11	MK110: Signals to power card (MK105) and fan power card (MK1200)
6	Rectifier(-) bus plate	12	Connection point for load share/regen (optional)

Illustration 13.5 Inrush Card and Inrush Card Frame

13.2.7 Inrush Card Frame and Rectifier Bus Plates

To remove or reinstall the inrush card frame and the rectifier bus plates, use the following steps. Refer to *Illustration 13.6*.

Disassembly

1. Remove the inrush card. Refer to *chapter 13.2.6 Inrush Card*.
2. Remove 3 nuts (7 mm), 1 from each inrush busbar, and remove the busbars.
3. Remove 4 nuts (7 mm) from the plastic inrush card frame, and remove the frame.
4. Remove 4 screws (T40), 1 from each SCR module and 1 from the DC coil. The screw in the DC coil is a smaller diameter.
5. If load share/regen option is present, remove 2 additional screws (T40). See *Illustration 13.5*.
6. Remove the rectifier(-) bus plate from the drive.
7. Remove the insulator sheet.
8. Remove 4 screws (T40), 1 from each SCR module and 1 from the DC coil. Remove the rectifier(+) bus plate from the drive.

Reassembly

Tighten fasteners according to *chapter 14.1 Fastener Torque Ratings*.

1. Place the rectifier(+) bus plate in its original position. Secure with 4 screws (T40), placing the smaller screw at the top of the bus plate.
2. Place the insulator sheet on the bus plate alignment pins.
3. Place the rectifier(-) bus plate in its original position. Secure with 4 screws (T40), placing the smaller screw at the top of the bus plate.
4. If load share/regen option is present, secure 2 additional screws (T40). See *Illustration 13.5*.
5. Replace the plastic inrush card frame, and secure the frame with 4 nuts (7 mm).
6. Replace the 3 inrush busbars. Secure with 3 nuts (7 mm), 1 in each busbar.
7. Reinstall the inrush card.

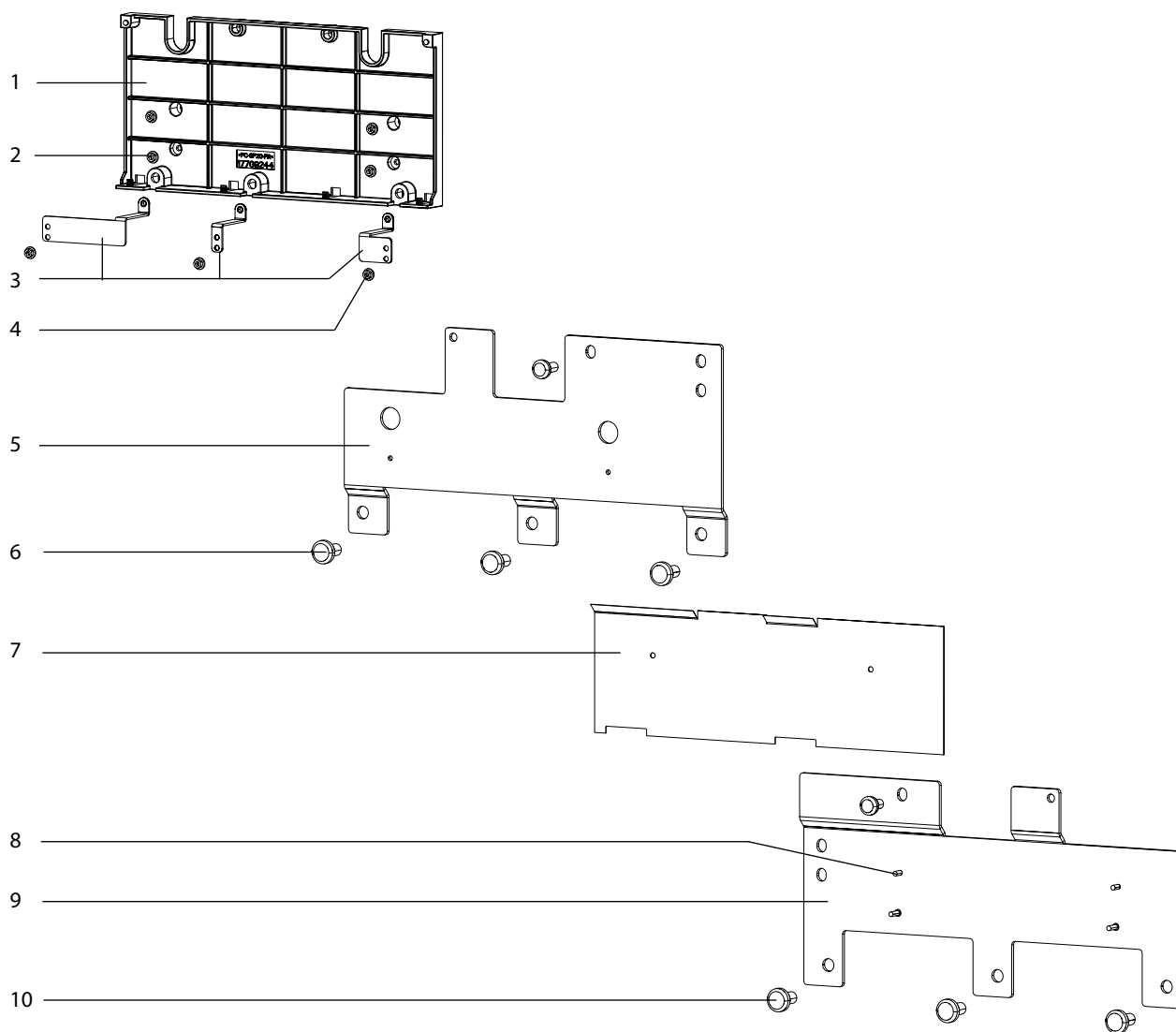

13

1	Inrush card frame	6	Bus plate screw (T40)
2	Nut (7 mm)	7	Insulator sheet
3	Inrush busbars	8	Insulator sheet alignment pin
4	Nut (7 mm)	9	Rectifier(+) bus plate
5	Rectifier(-) bus plate	10	Bus plate screw (T40)

Illustration 13.6 Inrush Card Frame and Rectifier Bus Plates

13.2.8 SCR/Diode Modules

E1h–E4h drives have 3 SCR/diode modules. To remove or reinstall an SCR/diode module, use the following steps. Refer to *Illustration 13.7*.

Disassembly

1. Remove the inrush card frame and rectifier bus plates. Refer to *chapter 13.2.7 Inrush Card Frame and Rectifier Bus Plates*.
2. Remove the input plate option. Refer to *chapter 13.2.10 Split Input Plate with Options*.
3. Remove 1 screw (T40), which connects the SCR input busbar to the SCR.
4. Remove 1 nut (8 mm) from the SCR input busbar. Remove the busbar from the drive.
5. Disconnect the cable from the SCR/diode module.
6. Remove 4 screws (T25), 1 from each corner of the SCR/diode module.
7. Remove the SCR/diode module from the drive.

Reassembly

For reassembly, use the SCR/diode module spare part instructions that come with the parts kit.

1.30BF844.10

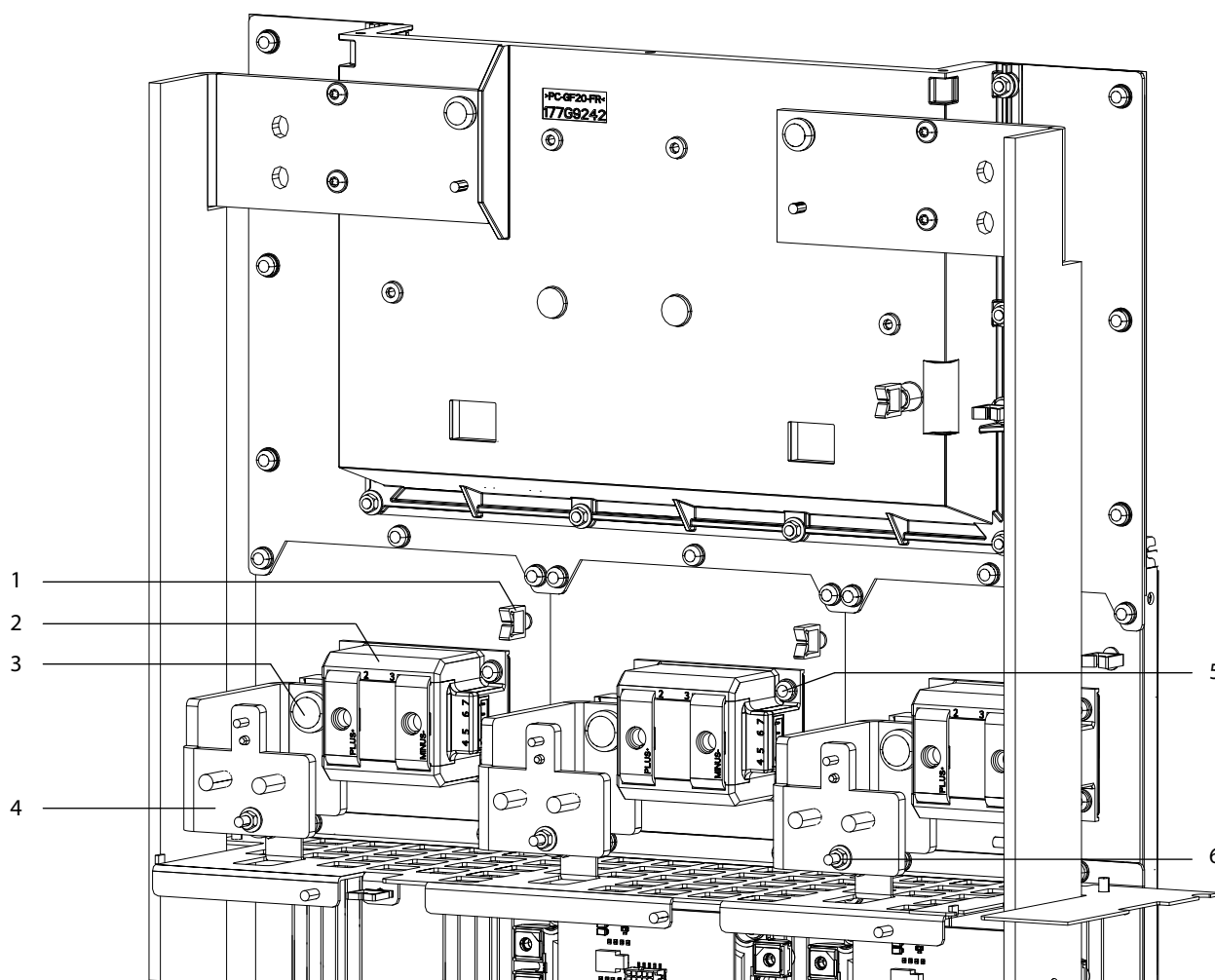

1	Cable retaining clip	4	SCR input busbar
2	SCR/diode module	5	Screw (T25)
3	Screw (T40)	6	Nut (8 mm)

Illustration 13.7 SCR/Diode Modules

13.2.9 Input Plate with Busbars

CAUTION

COMPONENT WEIGHT

The input plate can weight up to 20 kg (44 lb), depending on the input options. To avoid injury, lift the plate only with assistance.

Standard E1h–E4h drives include 3 input busbars mounted on a single input plate. Only IP00/IP20 drives without input options have a single input plate, all others have 2 plates. To remove or reinstall the input plate with attached busbars, use the following steps. Refer to *Illustration 13.8*.

If the drive includes optional components such as fuses, disconnect, or RFI filter, the input plate is split into an upper plate and lower plate. To remove the split input plate and options, refer to *chapter 13.2.10 Split Input Plate with Options*.

Disassembly

The AC input busbars can remain attached when the input plate is removed.

1. Unplug in-line connector attaching the mixing fan cables to the fans on the back of the input plate. E1h/E3h drives have 2 fans; E2h/E4h drives have 1 fan.
2. Release the cables from the cable retaining clips.
3. Remove 3 nuts (17 mm) and bolts, 1 from each input terminal connection (L1, L2, L3) at the bottom of the AC input busbars.
4. Remove 6 nuts (13 mm), 2 from the upper end of each AC input busbar.
5. Remove 10 nuts (8 mm) from the input plate edges.
6. Lift the plate and attached busbars from the drive.

NOTICE

UNIQUE TORQUE VALUES

Tighten nuts (8 mm), which attach the input plate to the mounting rail, to the unique torque value specified in the following steps. Tighten remaining fasteners according to *chapter 14.1 Fastener Torque Ratings*.

Reassembly

1. Position the input plate and attached busbars in the drive.
2. Secure 10 nuts (8 mm) around the edges of the input plate. Torque nuts that attach the input plate to the mounting rail to 3.91 Nm (34.6 lb-in).
3. Reattach in-line connector attaching the mixing fan cables to the fans on the back of the input plate. E1h/E3h drives have 2 fans; E2h/E4h drives have 1 fan.
4. Secure cables with cable retaining clips.
5. Secure 6 nuts (13 mm), 2 at the upper end of each AC input busbar.
6. Secure 3 nuts (17 mm) and bolts, 1 for each input terminal (L1, L2, L3) at the bottom of the AC input busbars.

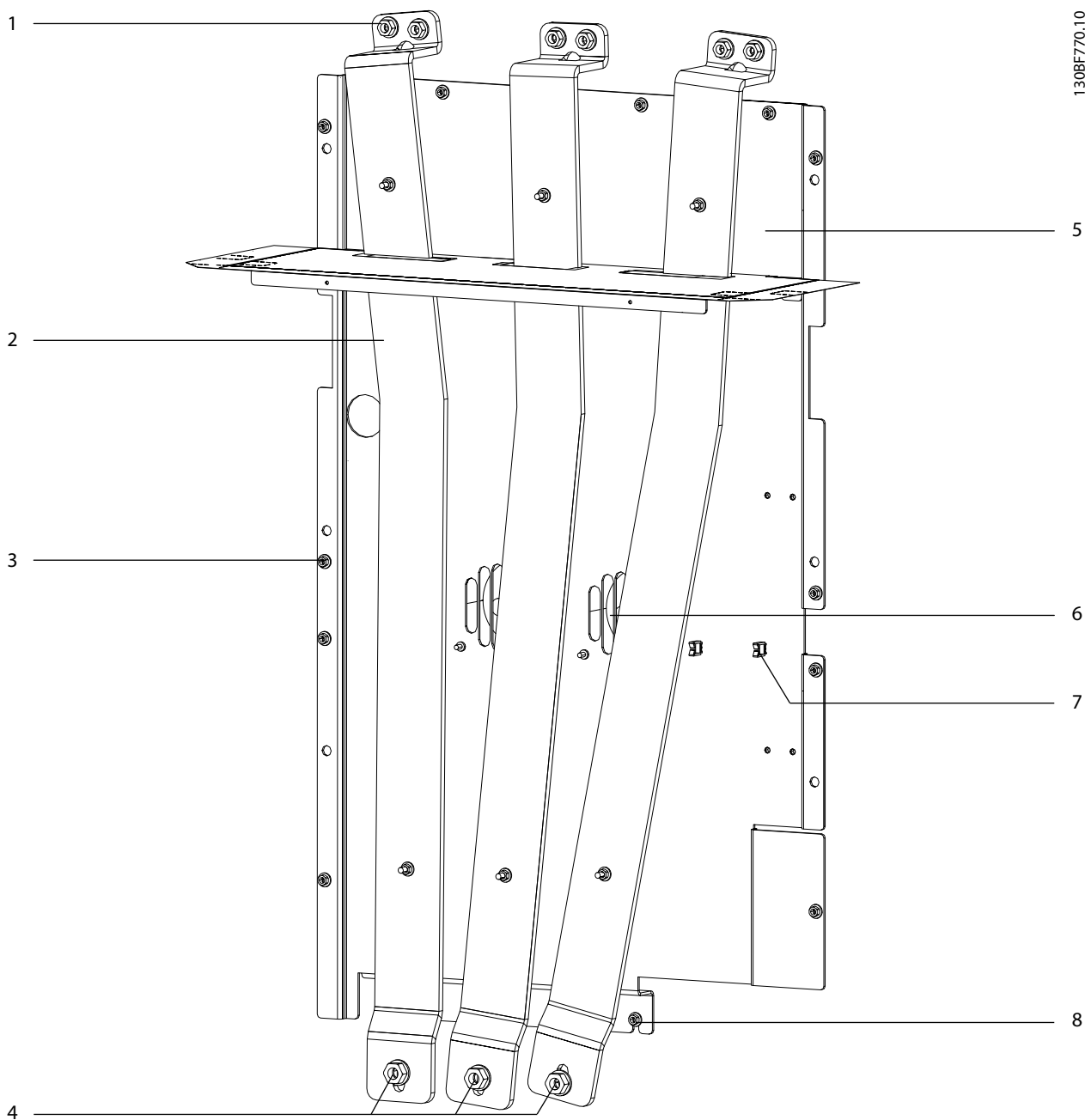

130BF770.10

13

1	Nut (13 mm)	5	Input plate
2	AC input busbar	6	Mixing fan vent (cable not shown)
3	Nut (8 mm)	7	Cable retaining clip
4	Nuts (17 mm) and bolts for L1, L2, L3 connection	8	Nut (8 mm)

Illustration 13.8 Single Input Plate with Busbars only

13.2.10 Split Input Plate with Options

CAUTION

COMPONENT WEIGHT

The upper and lower input plates with attached options can weigh up to 20 kg (44 lb), depending on the configuration. To avoid injury, lift the input plates only with assistance.

Standard E1h–E4h drives in IP00/IP20 enclosures include a single input plate. For drives with added options, the input plate is split into an upper input plate and lower input plate. These options include:

- AC fuses
- Disconnect
- RFI filter

To remove the split input plate and related options, use the following steps based on the configuration. Refer to *Illustration 13.9*. To remove or reinstall the single input plate with attached busbars, see *chapter 13.2.9 Input Plate with Busbars*.

Lower input plate with disconnect and AC fuse option

1. Remove 3 nuts (17 mm) and bolts, 1 from each input connection (L1, L2, L3) at the bottom of the disconnect.
2. Remove 3 nuts (17 mm) and bolts, 1 from the bottom of each fuse.
3. Remove 3 nuts (17 mm), 1 from the top of each fuse. Lift the fuses from the drive.
4. Remove 2 screws (T25) from the bottom of the lower input plate.
5. Remove 5–7 nuts (8 mm) from the lower input plate edge. The number of fasteners in the input plate varies with enclosure size.
6. Lift the lower input plate and attached disconnect from the drive.

Upper input plate with RFI filter option

1. Remove the lower input plate.
2. Unplug in-line connector attaching the mixing fan cables to the fans on the back of the input plate. E1h/E3h drives have 2 fans; E2h/E4h drives have 1 fan.
3. Unplug 2 RFI filter cable connectors on the right side of the RFI filter.
4. Release the cables from the cable retaining clips on the input plate.
5. Remove 6 nuts (13 mm), 2 from each AC input busbar at the top of the RFI filter.
6. Remove 6–8 nuts (8 mm) from the edges of the upper input plate. The number of fasteners in the input plate varies with enclosure size.
7. Lift the upper input plate with attached RFI filter from the drive.

Reassembly

Reinstall parts in the reverse order of these procedures.

NOTICE

UNIQUE TORQUE VALUES

Tighten nuts (8 mm), which attach the input plate to the mounting rail, to 3.91 Nm (34.6 lb-in). Tighten all other fasteners according to *chapter 14.1 Fastener Torque Ratings*.

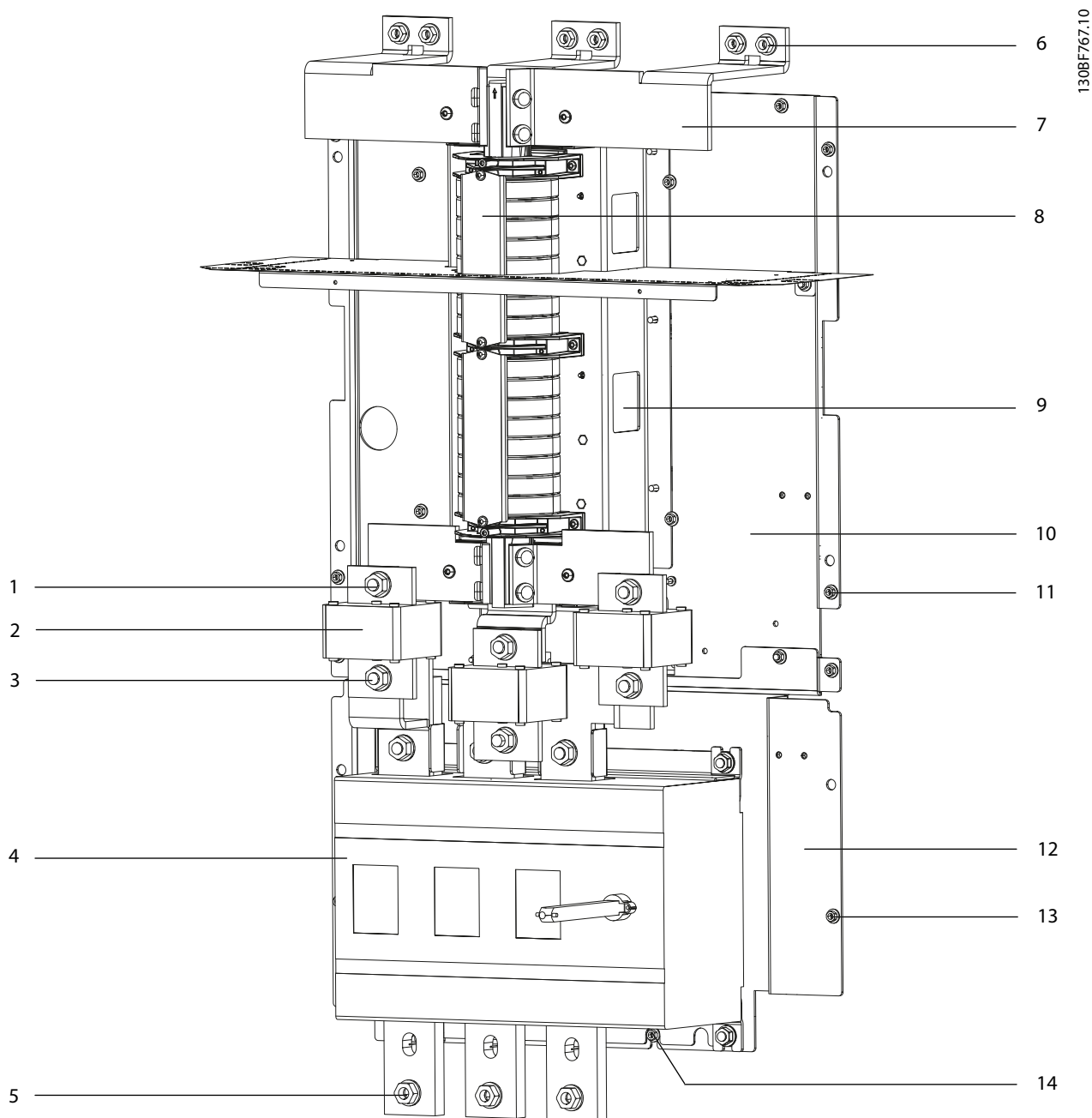

13

1	Nut (17 mm) in upper fuse	8	RFI filter
2	AC fuse	9	RFI cable access
3	Nut (17 mm) in lower fuse	10	Upper input plate
4	Disconnect	11	Nut (8 mm) in upper input plate
5	Nut (17 mm) at terminal L1	12	Lower input plate
6	Nut (30 mm) at upper RFI filter	13	Nut (8 mm) in lower input plate
7	AC input busbar	14	Nut (8 mm)

Illustration 13.9 Split Input Plate with Optional RFI Filter, AC Fuses, and Disconnect

13.2.11 Input Plate Mixing Fan

E1h/E3h drives have 2 mixing fans on the input plate. E2h/E4h drives have 1 mixing fan on the input plate, and 1 mixing fan below the power card. The input plate mixing fans are mounted on the back of the input plate. In drives with a split input plate, the mixing fans are on the upper input plate. To remove or reinstall an input plate mixing fan, use the following steps. Refer to *Illustration 13.10*.

To remove or reinstall the power card mixing fan, see *chapter 13.2.12 Power Card Mixing Fan*.

Disassembly

1. Unplug the in-line connector attaching the mixing fan cable at the front of the input plate.
2. Release the cable from the cable retaining clips on the input plate.
3. Remove the input plate. Refer to *chapter 13.2.9 Input Plate with Busbars* or *chapter 13.2.10 Split Input Plate with Options*.
4. Remove 2 screws (T20) from opposite corners of the fan assembly.
5. Feed the cable through the fan cable access hole.
6. Remove the mixing fan from the input plate.

Reassembly

Tighten fasteners according to *chapter 14.1 Fastener Torque Ratings*.

1. Feed the mixing fan cable through the cable access hole to the front of the input plate.
2. Position the fan on the back of the input plate with the bottom arrow pointing away from the input plate.
3. Secure 2 screws (T20) in opposite corners of the fan assembly.
4. Reinstall the input plate. Refer to *chapter 13.2.9 Input Plate with Busbars* or *chapter 13.2.10 Split Input Plate with Options*.
5. Connect the mixing fan cable in-line connector.
6. Route the cable through the cable retaining clips on the input plate.

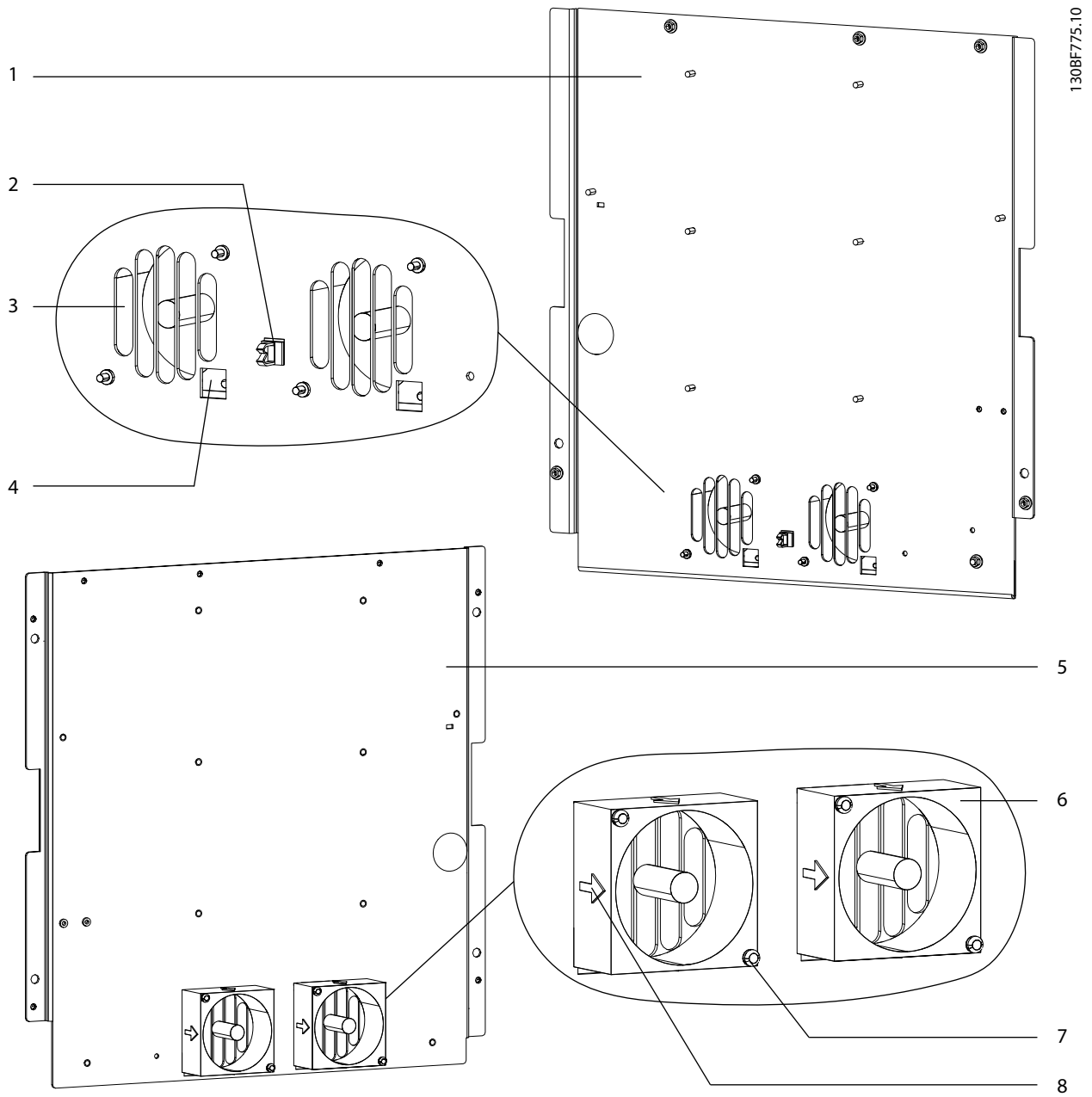

13

1	Upper input plate (front view, with options not shown)	5	Upper input plate (back view)
2	Cable retaining clip	6	Mixing fan
3	Mixing fan vent	7	Screw (T20)
4	Cable access hole	8	Alignment arrow

Illustration 13.10 E1h/E3h Input Plate Mixing Fan (E2h/E4h is Similar).

13.2.12 Power Card Mixing Fan

E2h/E4h drives have 1 mixing fan on the input plate, and 1 mixing fan below the power card. To remove or reinstall the power card mixing fan, use the following steps. Refer to *Illustration 13.11*.

To remove or reinstall the input plate mixing fan, see *chapter 13.2.11 Input Plate Mixing Fan*.

Disassembly

1. Remove the input plate. Refer to *chapter 13.2.9 Input Plate with Busbars* and *chapter 13.2.10 Split Input Plate with Options*.
2. Unplug the in-line connector attaching the mixing fan cable.
3. Remove 1 screw (T25) from the fan cage, and lift the fan cage from the drive.
4. Remove 2 screws (T20) from opposite corners of the mixing fan.
5. Feed the cable through the fan cable access hole.
6. Remove the mixing fan from the fan cage.

Reassembly

Tighten fasteners according to *chapter 14.1 Fastener Torque Ratings*.

1. Place the mixing fan inside the fan cage with the airflow arrow pointing upward toward the power card.
2. Feed the mixing fan cable through the cable access hole to the outside of the fan cage.
3. Secure 2 screws (T20) in opposite corners of the mixing fan.
4. Position the fan cage in the drive, and secure 1 screw (T25).
5. Connect the mixing fan cable in-line connector.
6. Replace the input plate. Refer to *chapter 13.2.9 Input Plate with Busbars* and *chapter 13.2.10 Split Input Plate with Options*.

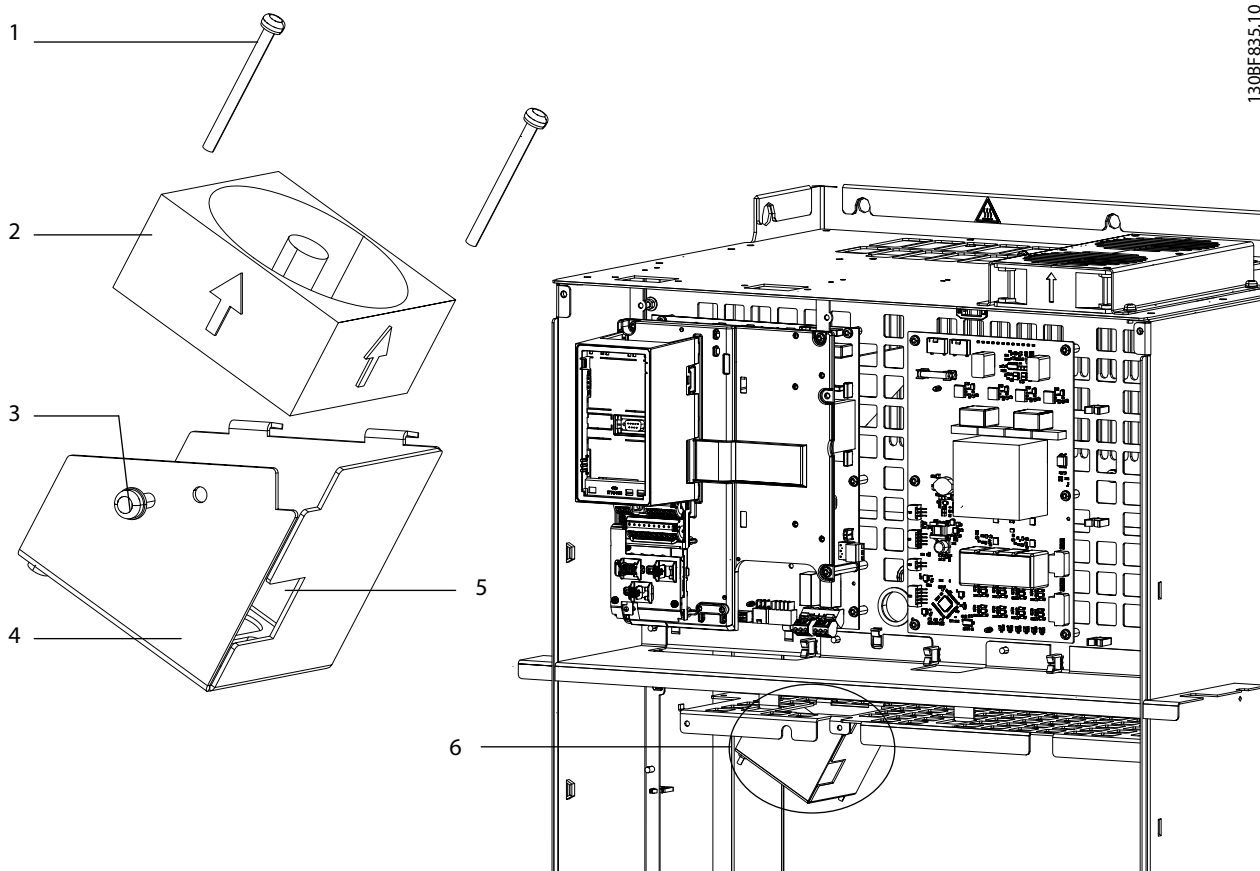

1	Fan screw (T20)	4	Fan cage
2	Mixing fan	5	Cable access hole
3	Screw (T25)	6	Fan location

Illustration 13.11 Power Card Mixing Fan

13.2.13 Gate Drive Card Mounting Plate

The gate drive card mounting plate can be removed from the drive with the gate drive card attached. To remove the gate drive card mounting plate from the drive, use the following steps. Refer to *Illustration 13.12*.

To remove the gate drive card from the mounting plate, see *chapter 13.2.14 Gate Drive Card*.

Disassembly

1. Remove the input plate and any attached options. Refer to *chapter 13.2.9 Input Plate with Busbars* and *chapter 13.2.10 Split Input Plate with Options*.
2. Unplug the cables from the following gate drive card connectors:
 - 2a MK100
 - 2b MK101
 - 2c MK201 (if brake option is present)
 - 2d MK501
 - 2e MK601
 - 2f MK701
3. Remove 4 screws (T20), 1 from each leg of the gate drive card mounting plate.
4. Lift the mounting plate with attached card from the unit.

NOTICE

CABLE ROUTING

To avoid equipment malfunction or damage, ensure that the IGBT cables are reattached to the correct IGBT cable connectors (MK501, MK601, and MK701).

Reassembly

Tighten fasteners according to *chapter 14.1 Fastener Torque Ratings*.

1. Place the mounting plate in its original position in the drive.
2. Secure 4 screws (T20), 1 in each leg of the gate drive card mounting plate.
3. Attach the cables to the following gate drive card connectors:
 - 3a MK100
 - 3b MK101
 - 3c MK201 (if brake option is present)
 - 3d MK501
 - 3e MK601
 - 3f MK701
4. Reinstall the input plate and any attached options. Refer to *chapter 13.2.9 Input Plate with Busbars* and *chapter 13.2.10 Split Input Plate with Options*.

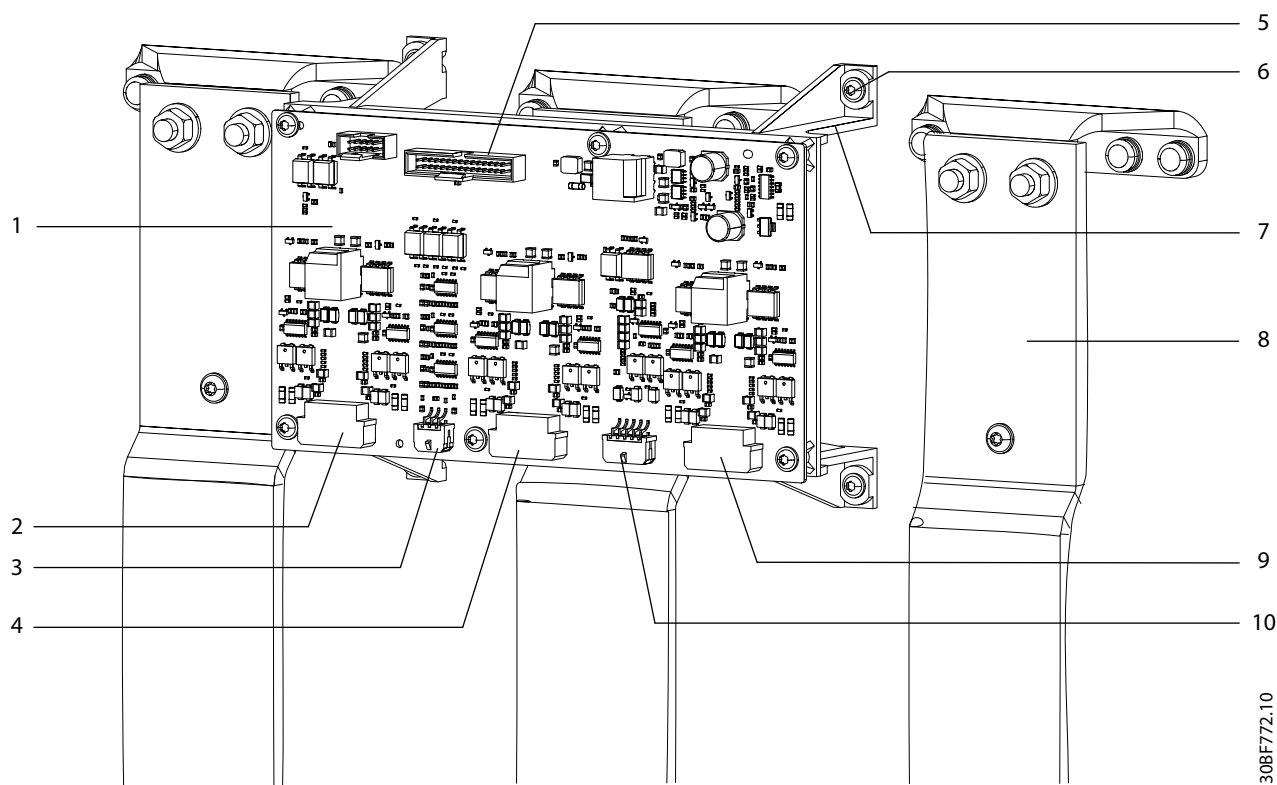

1308F772.10

1	Gate drive card	6	Screw (T20)
2	MK501	7	Leg of mounting plate
3	MK100	8	IGBT output busbar
4	MK601	9	MK701
5	MK101	10	MK 201 (for brake option)

Illustration 13.12 Gate Drive Card Mounting Plate

13.2.14 Gate Drive Card

To remove the gate drive card from the mounting plate, use the following steps. Refer to *Illustration 13.13*. To remove the gate drive card mounting plate from the drive, see *chapter 13.2.13 Gate Drive Card Mounting Plate*.

Disassembly

1. Remove the input plate and any attached options. Refer to *chapter 13.2.9 Input Plate with Busbars* or *chapter 13.2.10 Split Input Plate with Options*.
2. Unplug the cables from the following gate drive card connectors:
 - 2a MK100
 - 2b MK101
 - 2c MK201 (if brake option is present)
 - 2d MK501
 - 2e MK601
 - 2f MK701
3. Remove 6 screws (T20) from the edges of the gate drive card. Lift the gate drive card from the unit.

NOTICE

CABLE ROUTING

To avoid equipment malfunction or damage, ensure that the IGBT cables are reattached to the correct IGBT cable connectors (MK501, MK601, and MK701).

NOTICE

UNIQUE TORQUE VALUES

Tighten screws (T20) to the non-standard torque value specified in the following steps. Tighten remaining fasteners according to *chapter 14.1 Fastener Torque Ratings*.

Reassembly

1. Place the gate drive card into position on the gate drive card mounting plate.
2. Secure 6 screws (T20) in the edges of the gate drive card. Torque to 2.27 Nm (20.1 lb-in).
3. Attach the cables to the following gate drive card connectors:
 - 3a MK100
 - 3b MK101
 - 3c MK201 (if brake option is present).
 - 3d MK501
 - 3e MK601
 - 3f MK701
4. Reinstall the input plate and any options. Refer to *chapter 13.2.9 Input Plate with Busbars* and *chapter 13.2.10 Split Input Plate with Options*.

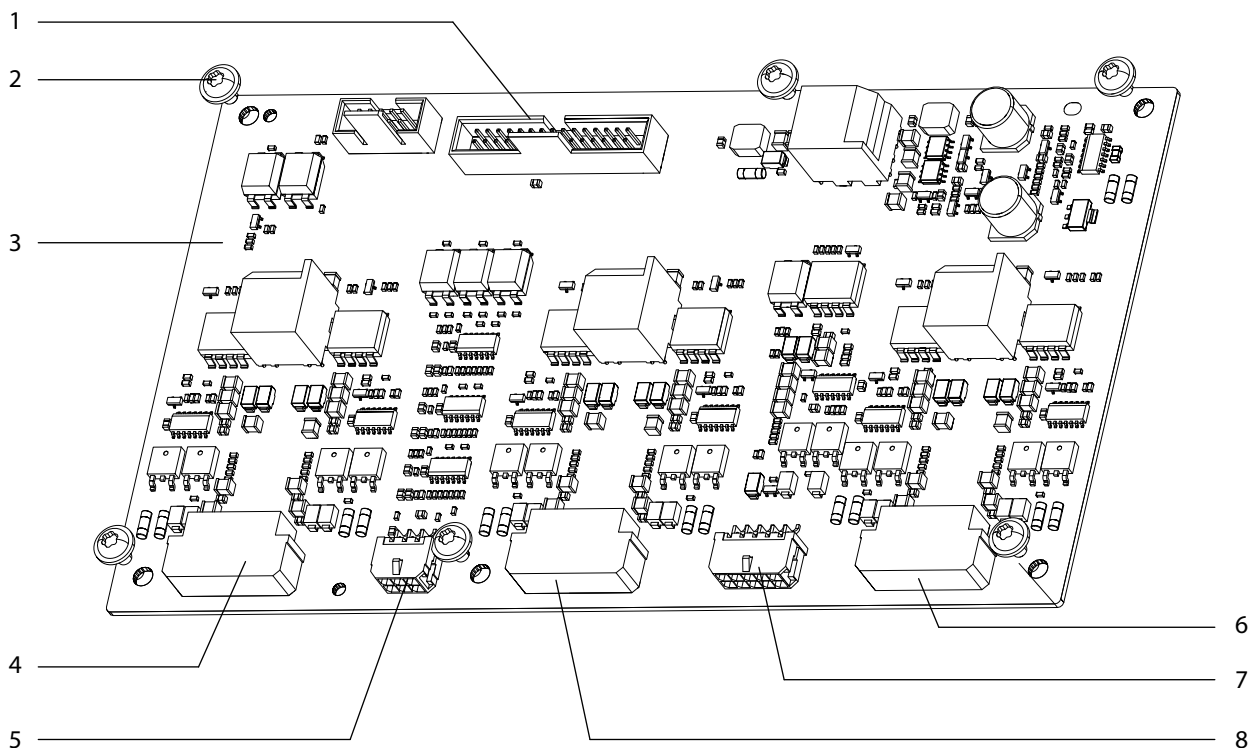

1.30BF773.10

1	MK101	5	MK100
2	Screw (T20)	6	MK701
3	Gate drive card	7	MK201 (optional brake)
4	MK501	8	MK601

Illustration 13.13 Gate Drive Card

13.2.15 Current Sensors

To remove or reinstall the current sensors, use the following steps. Refer to *Illustration 13.14*.

Disassembly

1. Remove the input plate. Refer to *chapter 13.2.9 Input Plate with Busbars* and *chapter 13.2.10 Split Input Plate with Options*.
2. Remove 12 nuts (13 mm), 2 from each end of the 3 motor busbars (starting with the left motor busbar). Lift the 3 motor busbars from the drive.
3. Remove 3 nuts (13 mm), 1 from the upper end of each current sensor busbar.
4. Remove 6 screws (T25), 2 from the middle of each current sensor busbar.
5. Unplug 3 current sensor cables, 1 from the top of each current sensor.
6. Unfasten 6 screws (T20), 2 from the base of each current sensor.
7. Lift the 3 current sensor busbars with current sensors from the drive.

NOTICE

ASSEMBLY NOTE

When installing current sensors, point the arrow on each current sensor downward. Failure to install the current sensors correctly can cause equipment malfunction.

Reassembly

Tighten fasteners according to *chapter 14.1 Fastener Torque Ratings*.

1. Place each current sensor on a current sensor busbar, and position the busbars in the drive.
2. Secure 6 screws (T20), 2 in the base of each current sensor.
3. Fasten 3 nuts (13 mm), 1 in the upper end of each current sensor busbar.
4. Secure 6 screws (T25), 2 in the middle of each current sensor busbar.
5. Connect the 3 current sensor cables, 1 at the top of each current sensor.
6. Position the motor busbars in the drive, starting with the right busbar. Secure 12 nuts (13 mm), 2 in each end of the 3 motor busbars.
7. Reinstall the input plate. Refer to *chapter 13.2.9 Input Plate with Busbars* and *chapter 13.2.10 Split Input Plate with Options*.

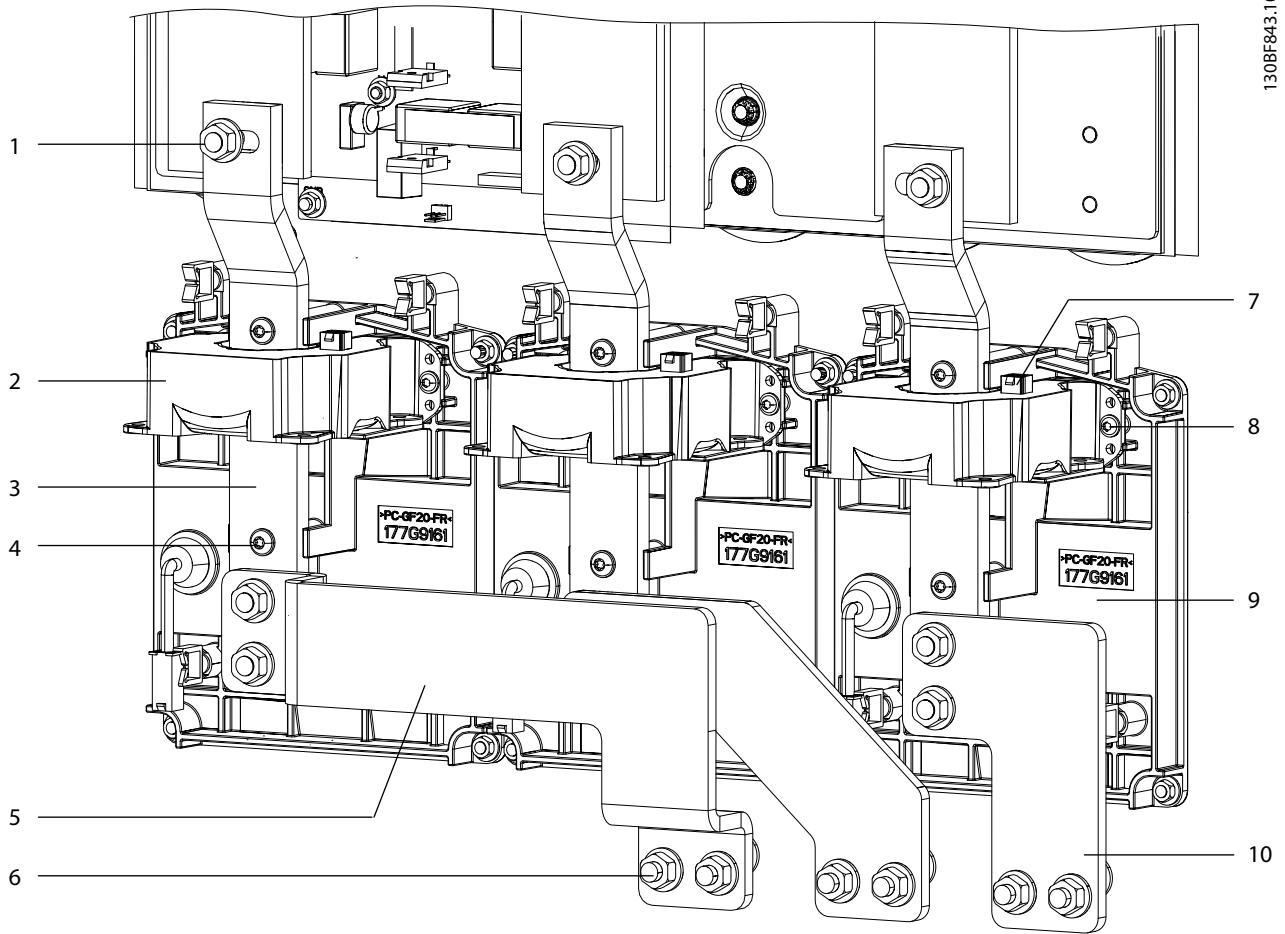

1	Nut (13 mm)	6	Lower nut (13 mm)
2	Current sensor	7	Current sensor cable connector
3	Current sensor busbar	8	Screw (T20)
4	Screw (T25)	9	Heat sink fan housing
5	Left motor busbar	10	Right motor busbar

13

Illustration 13.14 Current Sensors

13.2.16 Motor Busbar Assembly

To remove or reinstall the motor busbar assembly, use the following steps. Refer to *Illustration 13.15*.

Disassembly

1. Remove the input plate. Refer to *chapter 13.2.9 Input Plate with Busbars* and *chapter 13.2.10 Split Input Plate with Options*.
2. In E1h/E3h drives, remove the gate drive card mounting plate. See *chapter 13.2.13 Gate Drive Card Mounting Plate*.
3. Remove 12 nuts (13 mm), 2 from each end of the 3 motor busbars (starting with the left motor busbar). Lift the 3 motor busbars from the drive.
4. Remove 3 nuts (13 mm), 1 from the upper end of each current sensor busbar.
5. Remove 6 nuts (13 mm), 2 from the upper end of each IGBT output busbar.
6. Remove 3 screws (T20), 1 from the middle of each IGBT output busbar. This screw is not present in E2h/E4h drives.
7. Lift the IGBT output busbars from the drive.
8. Remove 6 screws (T25), 2 from the middle of each current sensor busbar.
9. Unplug 3 current sensor cables, 1 from the top of each current sensor.
10. Unfasten 6 screws (T20), 2 from the base of each current sensor.
11. Lift the 3 current sensor busbars with current sensors from the drive.

NOTICE

ASSEMBLY NOTE

When reinstalling current sensors, point the arrow on each current sensor downward. Failure to install the current sensors correctly can cause equipment malfunction.

Reassembly

Tighten fasteners according to *chapter 14.1 Fastener Torque Ratings*.

1. Place each current sensor on a current sensor busbar, and position the busbars in the drive. Check that the arrows on the current sensors point downward.
2. Secure 6 screws (T20), 2 in the base of each current sensor.
3. Position the IGBT output busbars in the drive. Secure 6 nuts (13 mm), 2 in the upper end of each IGBT output busbar.
4. Secure 3 screws (T20), 1 in the middle of each IGBT output busbar. This screw is not present in E2h/E4h drives.
5. Fasten 3 nuts (13 mm), 1 in the upper end of each current sensor busbar.
6. Secure 6 screws (T25), 2 in the middle of each current sensor busbar.
7. Connect the 3 current sensor cables, 1 at the top of each current sensor.
8. Position the motor busbars in the drive, starting with the right busbar. Secure 12 nuts (13 mm), 4 in each motor busbar.
9. Reinstall the gate drive card mounting plate, if removed. See *chapter 13.2.13 Gate Drive Card Mounting Plate*.
10. Reinstall the input plate. Refer to *chapter 13.2.9 Input Plate with Busbars* and *chapter 13.2.10 Split Input Plate with Options*.

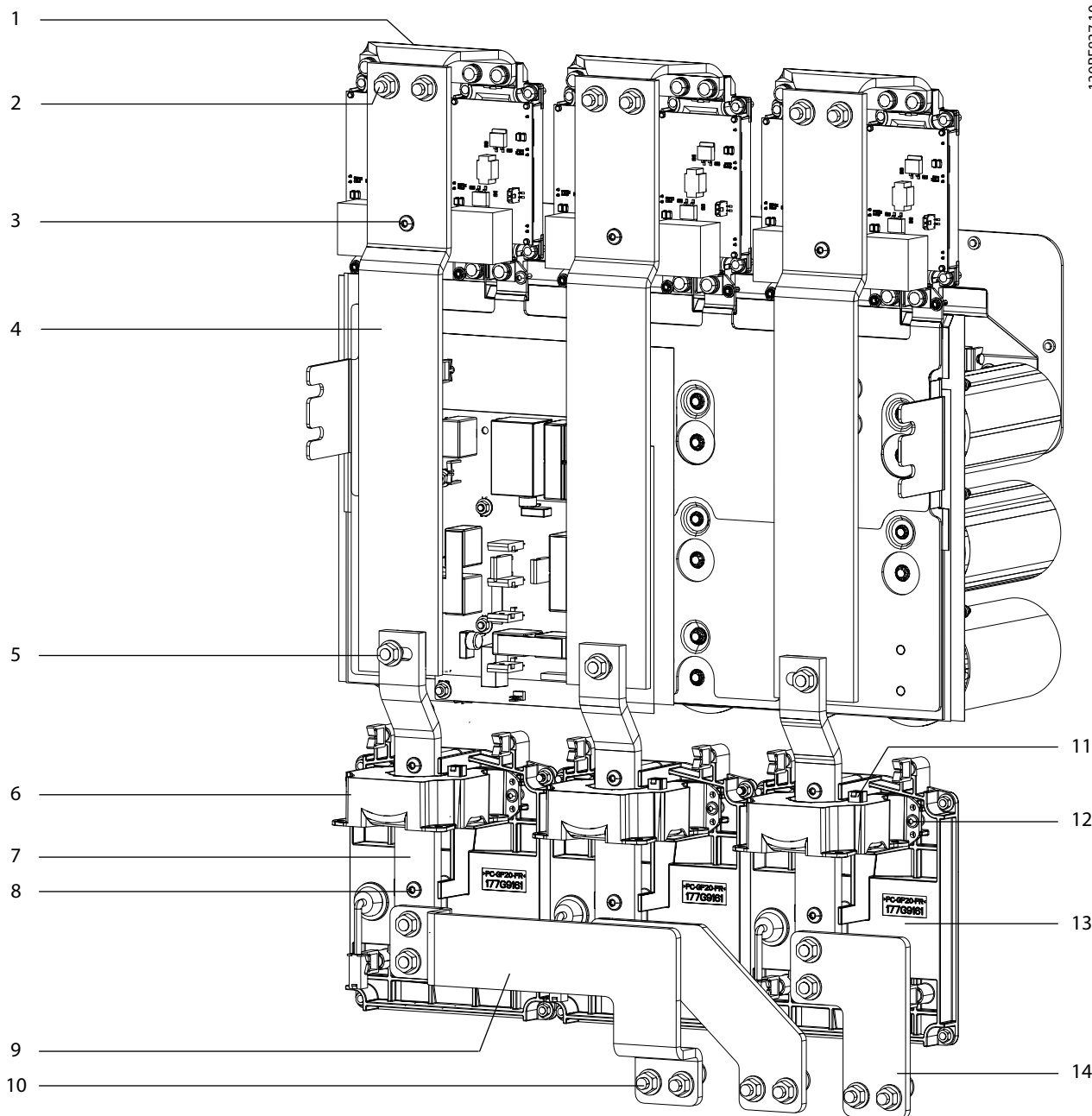

13

1	Y-shaped busbar	8	Screw (T25)
2	Nut (13 mm)	9	Left motor busbar
3	Screw (T25)	10	Nut (13 mm)
4	IGBT motor busbar	11	Current sensor cable connector
5	Nut (13 mm)	12	Screw (T20)
6	Current sensor	13	Heat sink fan housing
7	Current sensor busbar	14	Right motor busbar

Illustration 13.15 E1h/E3h Motor Busbar Assembly (E2h/E4h is Similar)

13.2.17 Balance/High Frequency Card

To remove or reinstall the balance/high frequency card, use the following steps. Refer to *Illustration 13.16*.

NOTICE

PARTS REUSE

In T7 units (525–690 V AC), retain the screw (T25) that is removed from the balance/high frequency card. Using a longer screw during reassembly can damage the insulator sheet behind the card.

Disassembly

1. Remove the input plate. Refer to *chapter 13.2.9 Input Plate with Busbars* or *chapter 13.2.10 Split Input Plate with Options*.
2. Remove the gate drive card mounting plate. Refer to *chapter 13.2.13 Gate Drive Card Mounting Plate*.
3. Remove the left IGBT output busbar by removing:
 - 3a 1 nut (13 mm) from the upper end of the left current sensor busbar.
 - 3b 2 nuts (13 mm) from the upper end of the left IGBT output busbar.
 - 3c 1 screw (T25) from the middle of the left IGBT output busbar. This screw is not present in E2h/E4h drives.
4. Remove the center IGBT output busbar by removing:
 - 4a 1 nut (13 mm) from the upper end of the center current sensor busbar.
 - 4b 2 nuts (13 mm) from the upper end of the center IGBT output busbar.
 - 4c 1 screw (T25) from the middle of the center IGBT output busbar. This screw is not present in E2h/E4h drives.
5. Unplug the cable from connector MK100 on the balance/high frequency card. This connector and cable are present only in T7 units (525–690 V AC).
6. Release the cable from the cable retaining clips.
7. Remove 4 nuts (8 mm) from the card, including those attaching the white DC(+) wire and black DC(-) wire. In T7 units (580–690 V AC), also remove 1 screw (T25), and retain the screw. Using a longer screw can damage the insulator sheet behind the card.
8. Lift the balance/high frequency card and the insulator sheet from the drive.

Reassembly

Tighten fasteners according to *chapter 14.1 Fastener Torque Ratings*.

1. Position the insulator sheet on the capacitor plate.
2. Place the balance/high frequency card over the insulator sheet.
3. Fasten 4 nuts (8 mm) in the balance/high frequency card, attaching the white wire at the DC(+) marking and the black wire at the DC(-) marking. In T7 units (580–690 V AC), also replace 1 screw (T25) that was retained during disassembly. A longer screw can damage the insulator sheet behind the card.
4. Attach the cable to the MK100 connector. This connector and cable are present only in T7 units (525–690 V AC).
5. Replace the center IGBT output busbar by securing:
 - 5a 2 nuts (13 mm) in the upper end of the center IGBT output busbar.
 - 5b 1 screw (T25) in the middle of the IGBT output busbar. This screw is not present in E2h/E4h drives.
 - 5c 1 nut (13 mm) in the upper end of the center current sensor busbar.
6. Replace the left IGBT output busbar by securing:
 - 6a 1 nut (13 mm) in the upper end of the left current sensor busbar.
 - 6b 2 nuts (13 mm) in the upper end of the left IGBT output busbar.
 - 6c 1 screw (T25) in the middle of the left IGBT output busbar. This screw is not present in E2h/E4h drives.
7. Reinstall the gate drive card mounting plate. Refer to *chapter 13.2.13 Gate Drive Card Mounting Plate*.
8. Reinstall the input plate. Refer to *chapter 13.2.9 Input Plate with Busbars* or *chapter 13.2.10 Split Input Plate with Options*.

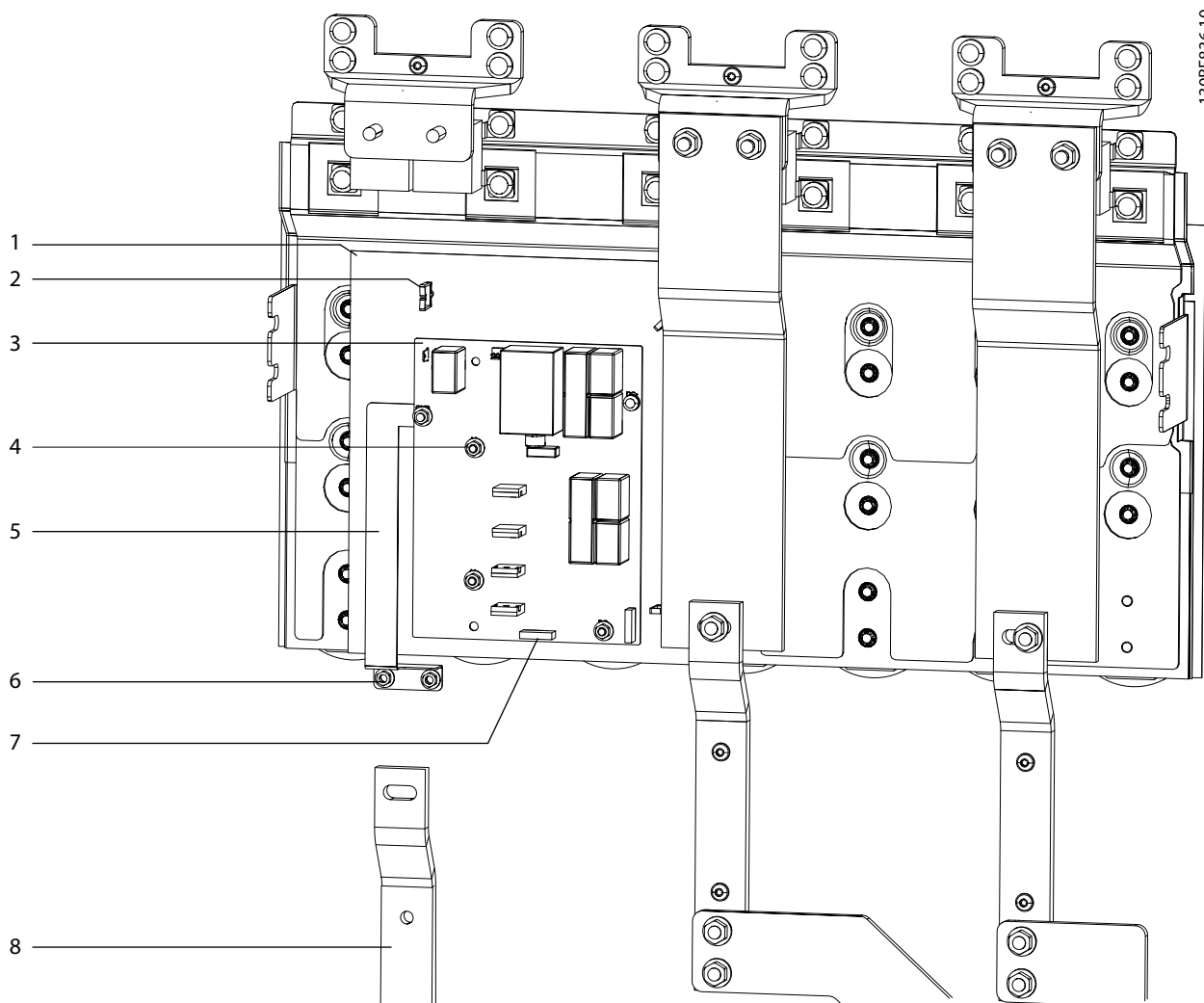

130BF836.10

13

1	Insulator sheet	5	Balance/high frequency card ground bar
2	Cable retaining clip	6	Ground bar nut (8 mm)
3	Balance/high frequency card	7	MK100 cable connector (only in 690 V drives)
4	Nut (8 mm)	8	Left current sensor busbar

Illustration 13.16 Balance/High Frequency Card in E2h/E4h, 580-690 V AC (Other Drives Similar)

13.2.18 Heat Sink Fan

E1h–E4h drives have 3 heat sink fans, 1 fan behind each current sensor. To remove or reinstall a heat sink fan, use the following steps. Refer to *Illustration 13.17*.

Disassembly

NOTICE

FAN ACCESS

If the brake option is present, remove the vertical brake busbars to access the right heat sink fan.

1. Remove the input plate. Refer to *chapter 13.2.9 Input Plate with Busbars* and *chapter 13.2.10 Split Input Plate with Options*.
2. Remove 12 nuts (13 mm), 4 from each motor busbar starting with the left motor busbar. Lift the 3 motor busbars from the drive.
3. Remove 3 nuts (13 mm), 1 from the upper end of each current sensor busbar.
4. Unplug 3 current sensor cables, 1 from the top of each current sensor.
5. Unplug the heat sink fan in-line connector.
6. Unfasten the fan cable from the cable retaining clips.
7. Remove 4 nuts (8 mm), 1 from each corner of the fan housing.
8. Pull the fan housing and fan forward, and remove both from the drive.
9. Squeeze together the top portion of the fan grommet until it pops through the hole in the fan housing, releasing the fan cable. Take care not to damage the fan wires during removal.
10. Remove the fan from the fan housing.

Reassembly

Tighten fasteners according to *chapter 14.1 Fastener Torque Ratings*.

1. Feed the fan cable through the hole in the fan housing.
2. Squeeze together the top portion of the fan grommet until it pops into place in the hole.
3. Position the heat sink fan in the slot in the fan housing and slide into the fan cutout. Ensure that the fan is fully seated in the back-channel.
4. Secure 4 nuts (8 mm), 1 in each corner of the fan housing.
5. Route the fan cable through the cable retaining clips.
6. Attach the heat sink fan cable in-line connector.
7. Fasten 3 nuts (13 mm), 1 in the upper end of each current sensor busbar.
8. Connect the 3 current sensor cables, 1 at the top of each current sensor.
9. Secure 12 nuts (13 mm), 4 in each motor busbar starting with the right motor busbar.
10. Replace the input plate. Refer to *chapter 13.2.9 Input Plate with Busbars* and *chapter 13.2.10 Split Input Plate with Options*.

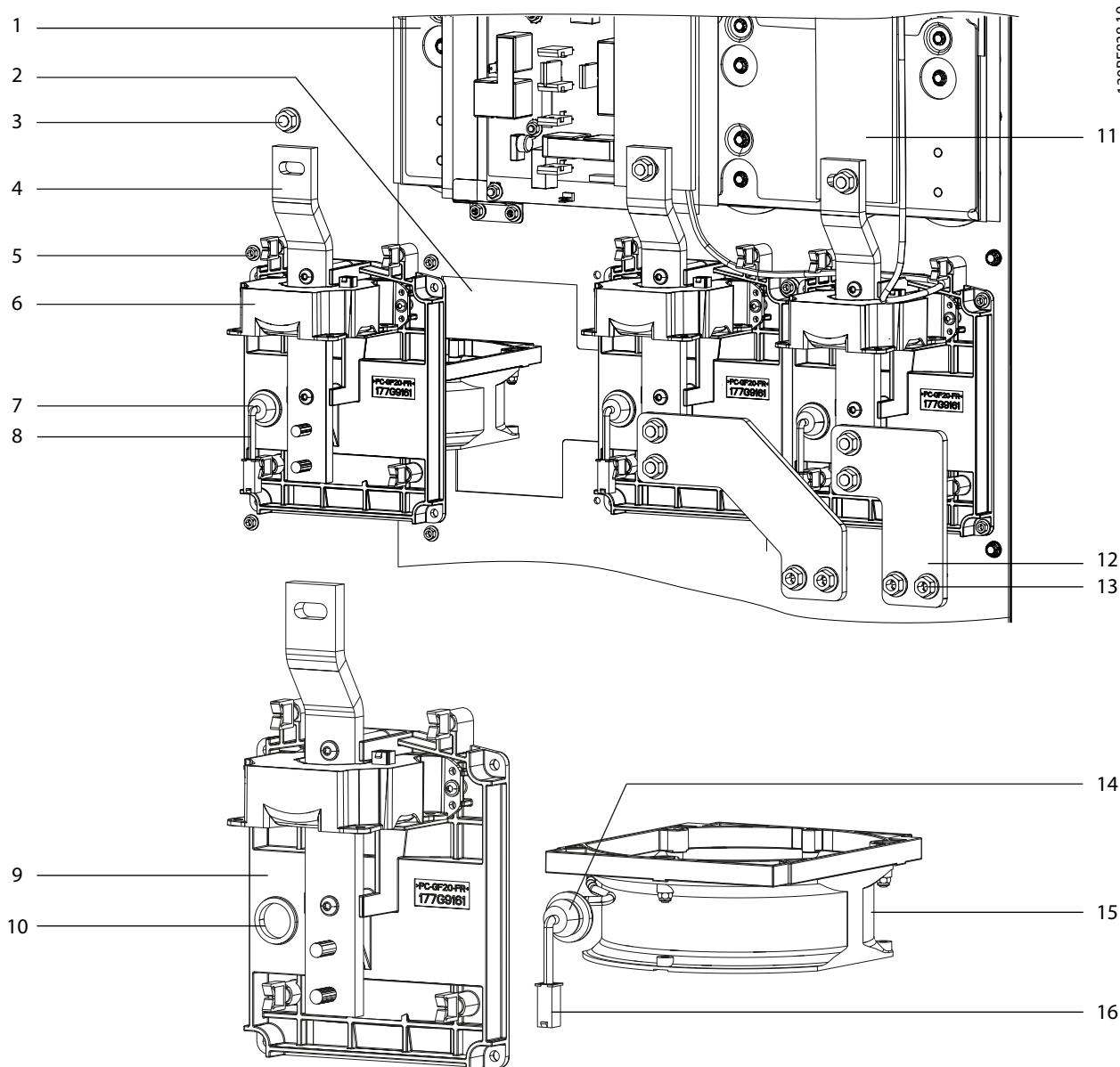

13

1	DC capacitor bank	9	Heat sink fan housing
2	Fan cutout	10	Hole for fan grommet
3	Nut (13 mm)	11	IGBT output busbar
4	Current sensor busbar	12	Right motor busbar
5	Nut (8 mm)	13	Nut (13 mm)
6	Current sensor	14	Fan grommet
7	Fan grommet (installed in fan housing)	15	Heat sink fan
8	Fan cable heat sink fan	16	Fan cable connector

Illustration 13.17 Heat Sink Fan (Shown with Left Motor Busbar Removed)

13.2.19 DC Snubber Capacitors

To remove or reinstall the DC snubber capacitors, select either the following procedure for E1h/E3h drives or the procedure for E2h/E4h drives.

Disassembly in E1h/E3h drives

In E1h/E3h drives, the DC snubber capacitors are located along the top of the DC capacitor plates. Refer to *Illustration 13.18*.

1. Remove the input plate. Refer to *chapter 13.2.9 Input Plate with Busbars* and *chapter 13.2.10 Split Input Plate with Options*.
2. Remove the gate drive card mounting plate. Refer to *chapter 13.2.13 Gate Drive Card Mounting Plate*.
3. Remove 3 nuts (13 mm), 1 from the top of each current sensor busbar.
4. Remove 3 screws (T25), 1 from the middle of each IGBT output busbar.
5. Remove 6 nuts (13 mm), 2 from the top of each IGBT output busbar. Lift the 3 IGBT output busbars from the drive.
6. Remove 12 screws (T30), 2 from the bottom of each DC snubber capacitor.
7. Remove the 6 DC snubber capacitors from the drive.

Reassembly in E1h/E3h drives

Tighten fasteners according to *chapter 14.1 Fastener Torque Ratings*.

1. Position the DC snubber capacitors in the drive.
2. Secure 12 screws (T30), 2 at the bottom of each DC snubber capacitor.
3. Position the IGBT output busbars in the drive. Secure 6 nuts (13 mm), 2 at the top of each IGBT output busbar.
4. Replace 3 screws (T25), 1 in the middle of each IGBT output busbar.
5. Secure 3 nuts (13 mm) 1 at the top of each current sensor busbar.
6. Replace the gate drive card mounting plate. Refer to *chapter 13.2.13 Gate Drive Card Mounting Plate*.
7. Replace the input plate. Refer to *chapter 13.2.9 Input Plate with Busbars* and *chapter 13.2.10 Split Input Plate with Options*.

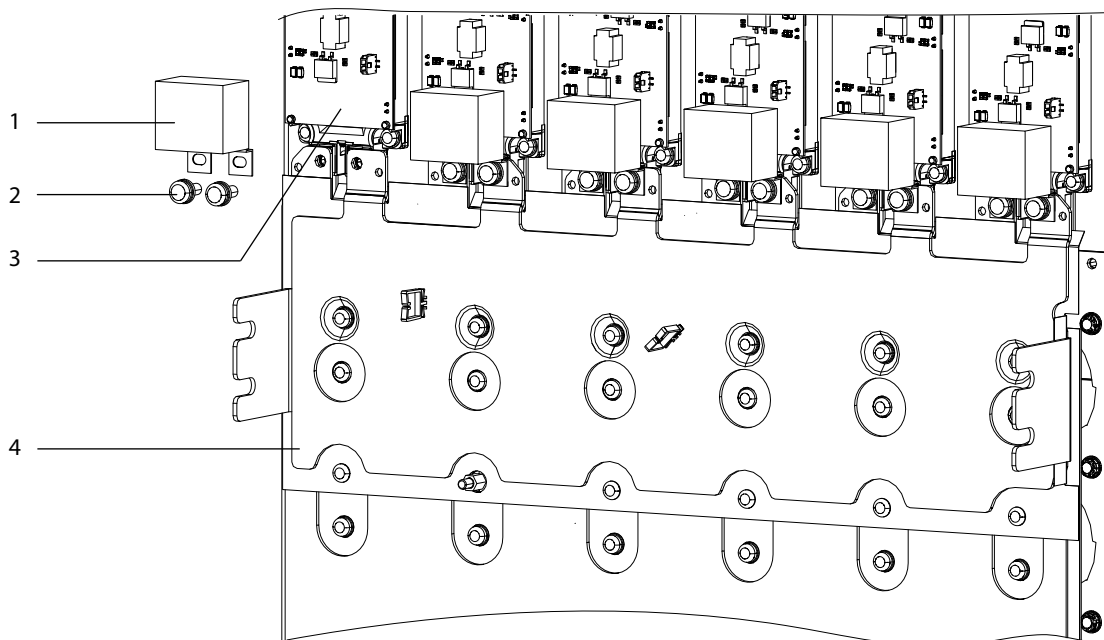

1308F876.10

1	DC snubber capacitor	3	IGBT module
2	Screw (T30)	4	DC bus plates

Illustration 13.18 DC Snubber Capacitors in E1h/E3h Drives

Disassembly in E2h/E4h drives

In E2h/E4h drives, the DC snubber capacitors are located under the Y-shaped busbars. Refer to *Illustration 13.19*.

1. Remove the input plate. Refer to *chapter 13.2.9 Input Plate with Busbars* and *chapter 13.2.10 Split Input Plate with Options*.
2. Remove 3 nuts (13 mm), 1 at the top of each current sensor busbar.
3. Remove 6 nuts (13 mm), 2 at the top of each IGBT output busbar. Remove the IGBT output busbars from the drive.
4. Remove 12 nuts (40 mm), 4 each DC snubber capacitor pair.
5. Remove the 3 DC snubber capacitor pairs from the drive.

Reassembly in E2h/E4h drives

Tighten fasteners according to *chapter 14.1 Fastener Torque Ratings*.

1. Place the DC snubber capacitor pairs in the drive.
2. Secure 12 nuts (40 mm), 4 in each DC snubber capacitor pair.
3. Position the IGBT output busbars in the drive. Secure 6 nuts (13 mm), 2 at the top of each IGBT output busbar.
4. Secure 3 nuts (13 mm), 1 at the top of each current sensor busbar.
5. Replace the input plate. Refer to *chapter 13.2.9 Input Plate with Busbars* and *chapter 13.2.10 Split Input Plate with Options*.

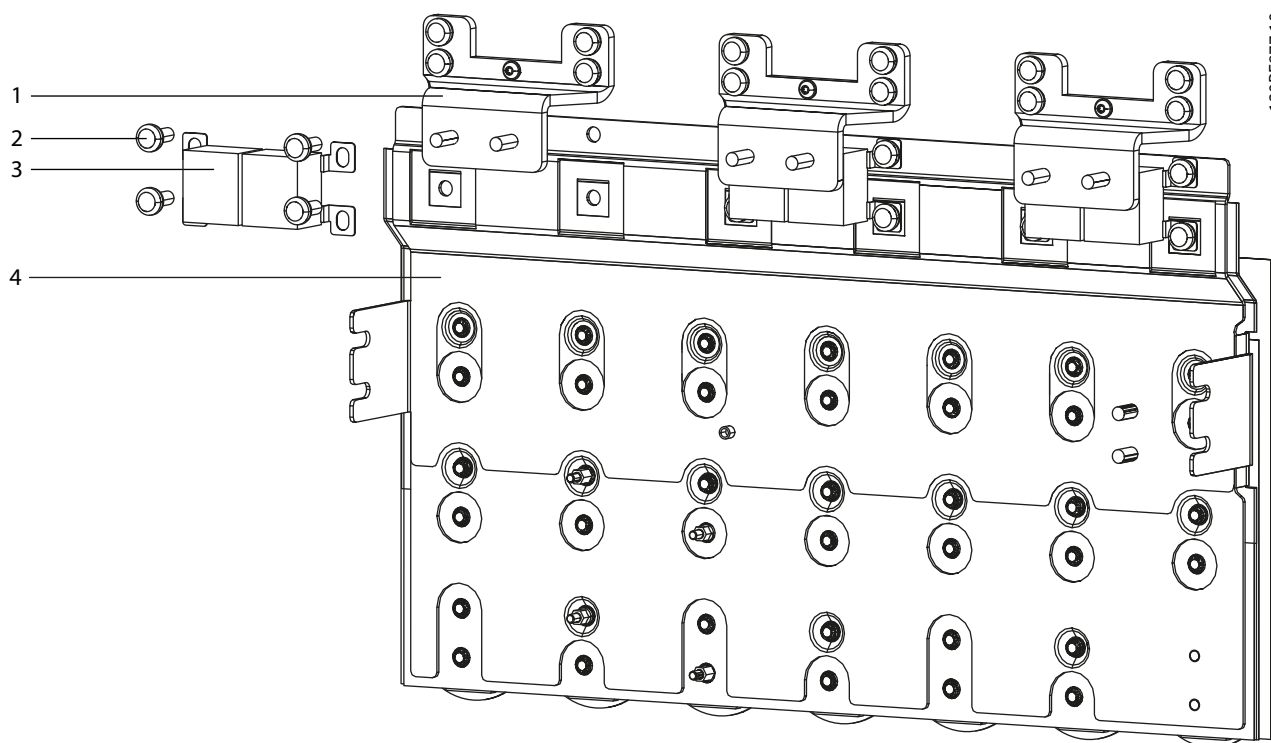

13

1	Y-shaped busbar	3	DC snubber capacitor pair
2	Nut (40 mm)	4	DC bus plates

Illustration 13.19 DC Snubber Capacitors in E2h/E4h Drives

13.2.20 Twistlock DC Capacitors

To remove or reinstall the twistlock DC capacitors, select the following procedure for either 380–500 V AC (T5) drives or 525–690 V AC (T7) drives. The capacitor bank assembly in T5 drives includes a DC(+) bus plate, DC(-) bus plate, and a single midplate. The capacitor bank assembly in T7 drives includes a DC(+) bus plate, DC(-) bus plate, and 2 midplates.

DC capacitor banks also differ in the number of capacitors present and the location of fasteners, such as screws and standoffs. The drive size and power rating determine the layout of the DC capacitor bank. Refer to *chapter 13.2.21 DC Capacitor Layouts* to find the capacitor layout and fastener locations for each drive.

NOTICE

FASTENER LOCATION

In addition to multiple screws, the DC capacitor bank assembly includes 3 standoffs that help secure the DC bus plates and midplates to the capacitors. Note the locations of the standoffs when removing them, and check the relevant capacitor layout for the location of all fasteners. See *chapter 13.2.21 DC Capacitor Layouts*.

Disassembly for 380–500 V AC units

1. Remove the balance/high frequency card. Refer to *chapter 13.2.17 Balance/High Frequency Card*.
2. Remove the DC snubber capacitors. See *chapter 13.2.19 DC Snubber Capacitors*.
3. Remove the 3 Y-shaped busbars by removing:
 - 3a 12 screws (T40), 4 from each Y-shaped busbar.
 - 3b 3 screws (T25), 1 from the center of each Y-shaped busbar. Lift the Y-shaped busbars from the drive.
4. Remove 2 nuts (30 mm) from left DC bus rail where it connects with the DC(+) bus plate.
5. Remove screws (T25) and any standoff from the DC(+) bus plate. Number and type of fasteners varies with drive size and power rating. Refer to the capacitor layout.
6. Lift the DC(+) bus plate from the drive, and remove the insulator sheet behind it.
7. Remove screws (T20), and any standoff (8 mm) from the midplate. Number of fasteners varies with drive size and power rating. Refer to the capacitor layout.
8. Lift the midplate from the drive, and remove the insulator sheet behind it.
9. Remove screws (T25) and any standoff (8 mm) from the DC(-) bus plate. Number of fasteners varies with drive size and power rating. Refer to the capacitor layout.
10. Lift the DC(-) bus plate from the drive, and remove the insulator sheet behind it.
11. To remove a DC capacitor, use the special tool provided in the parts kit (or grip the edges with a large pliers).

12. Turn the DC capacitor approximately 30 degrees counterclockwise to release it. Pull the capacitor out of the drive.

Reassembly for 380–500 V AC units

Tighten fasteners according to *chapter 14.1 Fastener Torque Ratings*.

1. Align the arrow on the rim of the DC capacitor with the notch in the cutout hole, and insert it into the drive.
2. Turn the DC capacitor clockwise approximately 30 degrees until it locks in place. Check that the capacitor gasket is fully seated.
3. Replace the DC bus plates and insulator sheets in reverse order, using the capacitor layout for the specific drive. Refer to *chapter 13.2.21 DC Capacitor Layouts*.
4. Replace any other components in reverse order of removal.

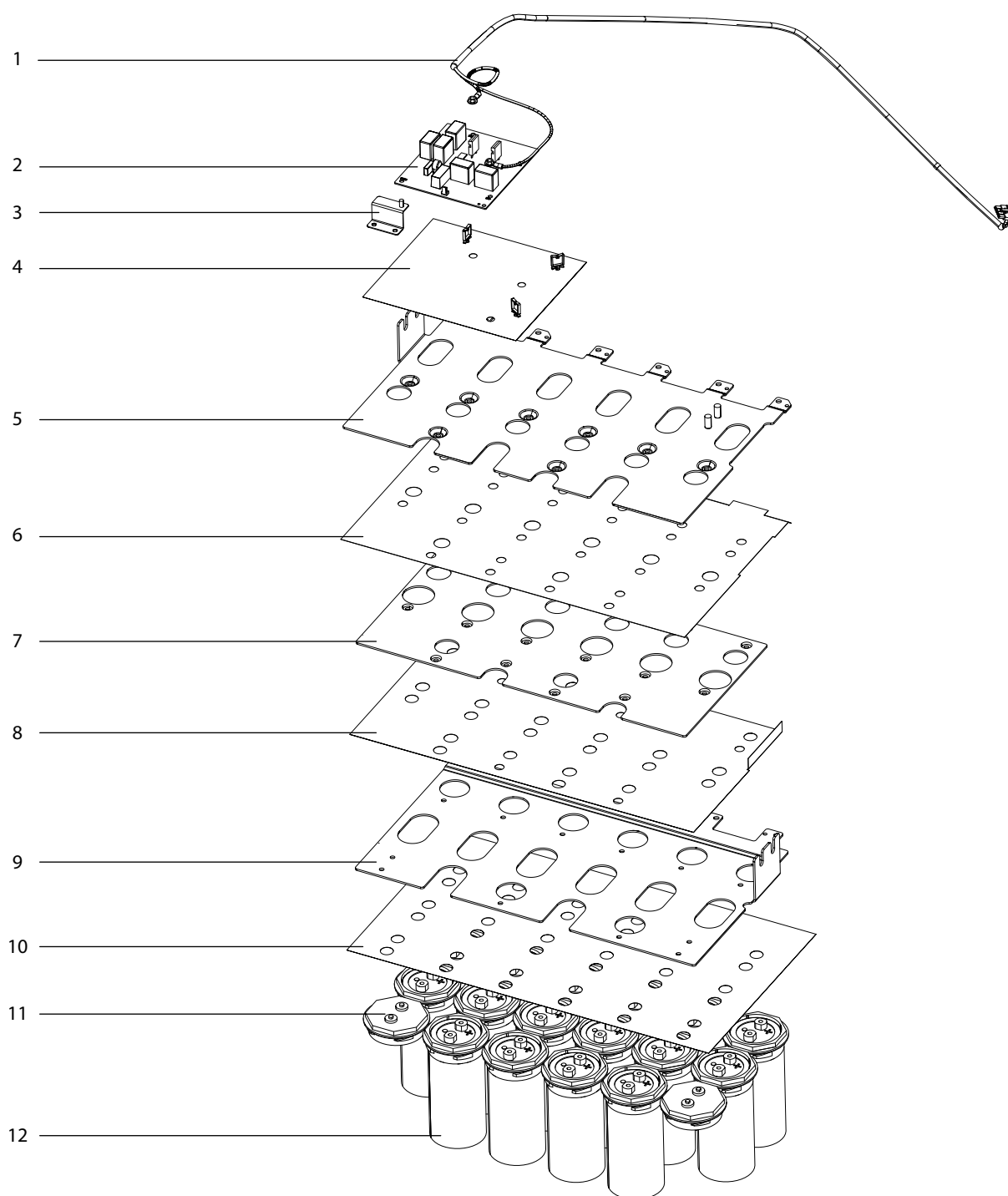

13

1	DC power cable (to power card shelf)	7	Midplate
2	Balance/high frequency card	8	Insulator sheet 2
3	Ground bar	9	DC(-) bus plate
4	Insulator sheet (for balance/high frequency card)	10	Insulator sheet 3
5	DC(+) bus plate	11	Plug
6	Insulator sheet 1	12	DC capacitor

Illustration 13.20 E1h/E3h Capacitor Bank, 380-500 V AC (T5), 16 DC Capacitors

Disassembly for 525–690 V AC units

1. Remove the balance/high frequency card. Refer to *chapter 13.2.17 Balance/High Frequency Card*.
2. Remove the DC snubber capacitors. See *chapter 13.2.19 DC Snubber Capacitors*.
3. Remove 2 nuts (30 mm) from left DC bus rail where it connects with the DC(+) bus plate.
4. Remove screws (T25) and any standoff (8 mm) from the DC(+) bus plate. Number of fasteners varies with drive size and power rating. Refer to *chapter 13.2.21 DC Capacitor Layouts*.
5. Lift the DC(+) bus plate from the drive, and remove the insulator sheet behind it.
6. Remove 2 nuts (30 mm) from right DC bus rail where it connects with the DC(-) bus plate.
7. Remove screws (T20) and any standoff (8 mm) from the DC(-) bus plate. Number of fasteners varies with drive size and power rating. Refer to *chapter 13.2.21 DC Capacitor Layouts*.
8. Lift the DC(-) bus plate from the drive, and remove the insulator sheet behind it.
9. Remove screws (T20) from the upper and lower midplates. Number of fasteners varies with drive size and power rating. Refer to *chapter 13.2.21 DC Capacitor Layouts*.
10. Lift the 2 midplates from the drive, and remove the insulator sheet behind it.
11. To remove a DC capacitor, use the special tool provided in the parts kit (or grip the edges with a large pliers).
12. Turn the DC capacitor approximately 30 degrees counterclockwise to release it. Pull the capacitor out of the drive.

Reassembly for 525–690 V AC units

Tighten fasteners according to *chapter 14.1 Fastener Torque Ratings*.

1. Align the arrow on the rim of the DC capacitor with the notch in the cutout hole, and insert it into the drive.
2. Turn the DC capacitor clockwise approximately 30 degrees until it locks in place. Check that the capacitor gasket is fully seated.
3. Replace the DC bus plates and insulator sheets in reverse order, using the capacitor layout for the specific drive. Refer to *chapter 13.2.21 DC Capacitor Layouts*.
4. Replace any other components in reverse order of removal.

130BF928.10

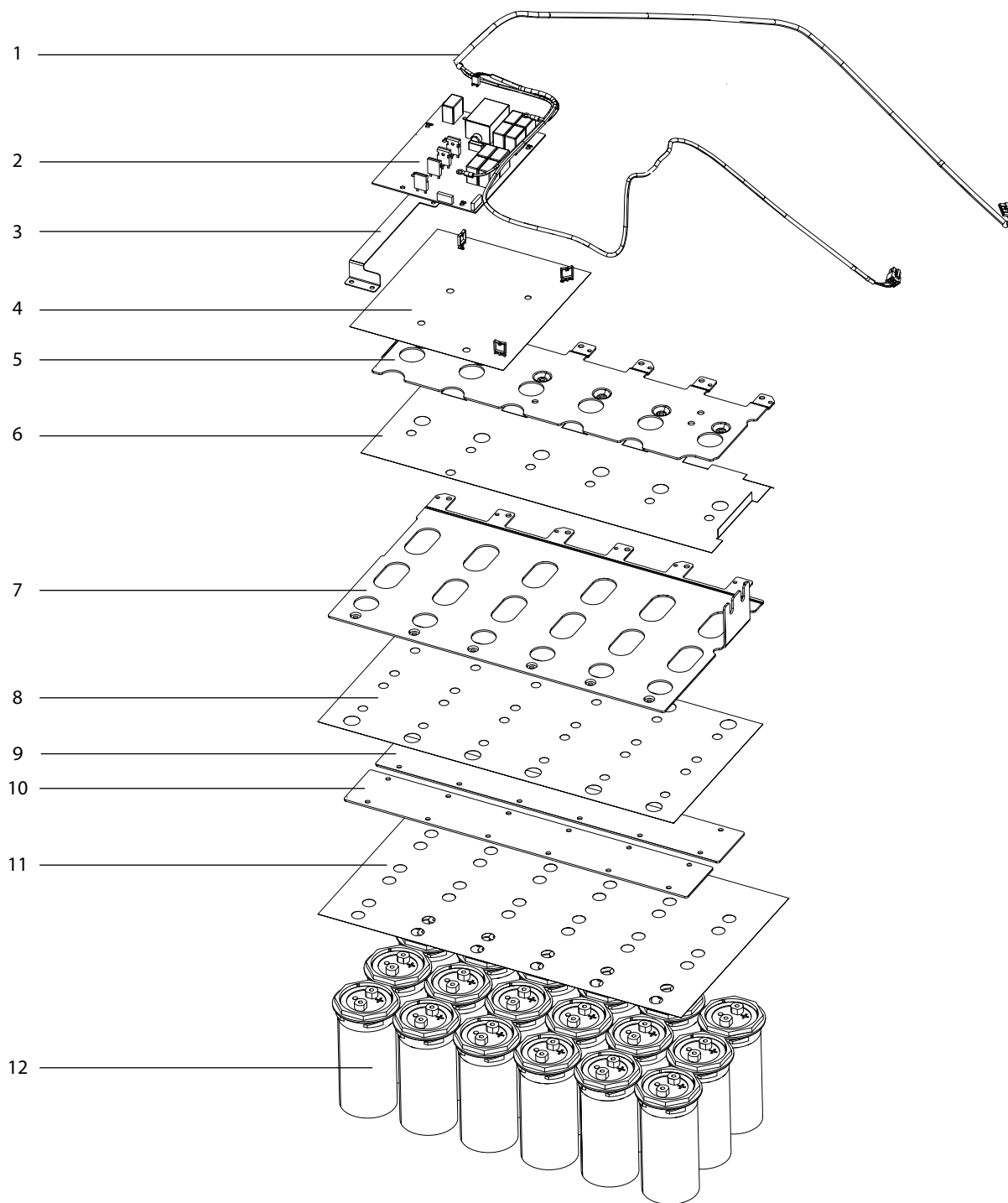

13

1	DC power cable (to power card shelf)	7	DC(-) bus plate
2	Balance/high frequency card	8	Insulator sheet 2
3	Ground bar	9	Midplate 1 (upper)
4	Insulator sheet (for balance/high frequency card)	10	Midplate 2 (lower)
5	DC(+) bus plate	11	Insulator sheet 3
6	Insulator sheet 1	12	DC capacitors

Illustration 13.21 E1h/E3h Capacitor Bank, 525-690 V AC (T7), 18 DC Capacitors

13.2.21 DC Capacitor Layouts

DC capacitor banks differ in the number of capacitors present and the location of fasteners, such as screws and standoffs. The drive size and power rating determine the layout of the DC capacitor bank. Use *Table 13.3* and *Table 13.4* to find the capacitor bank layout and fastener locations for a particular drive. Each illustration includes a table that lists which fasteners are screws or standoffs, and which DC bus plate or midplate they secure.

Illustration number	Model	
	FC 102, FC 103, and FC 202	FC 302
<i>Illustration 13.22</i>	N355T4	N315T5
<i>Illustration 13.23</i>	N400T4 N450T4	N355T5 N400T5
<i>Illustration 13.25</i>	N500T4 N560T4	N450T5 N500T5

Table 13.3 DC Capacitor Bank Layout 380–500 V

Illustration number	Model	
	FC 102, FC 103, and FC 202	FC 302
<i>Illustration 13.24</i>	N450T7 N500T7	N355T7 N400T7
<i>Illustration 13.26</i>	N560T7 N630T7	N500T7 N560T7
<i>Illustration 13.27</i>	N710T7 N800T7	N630T7 N710T7

Table 13.4 DC Capacitor Bank Layout 525–690 V

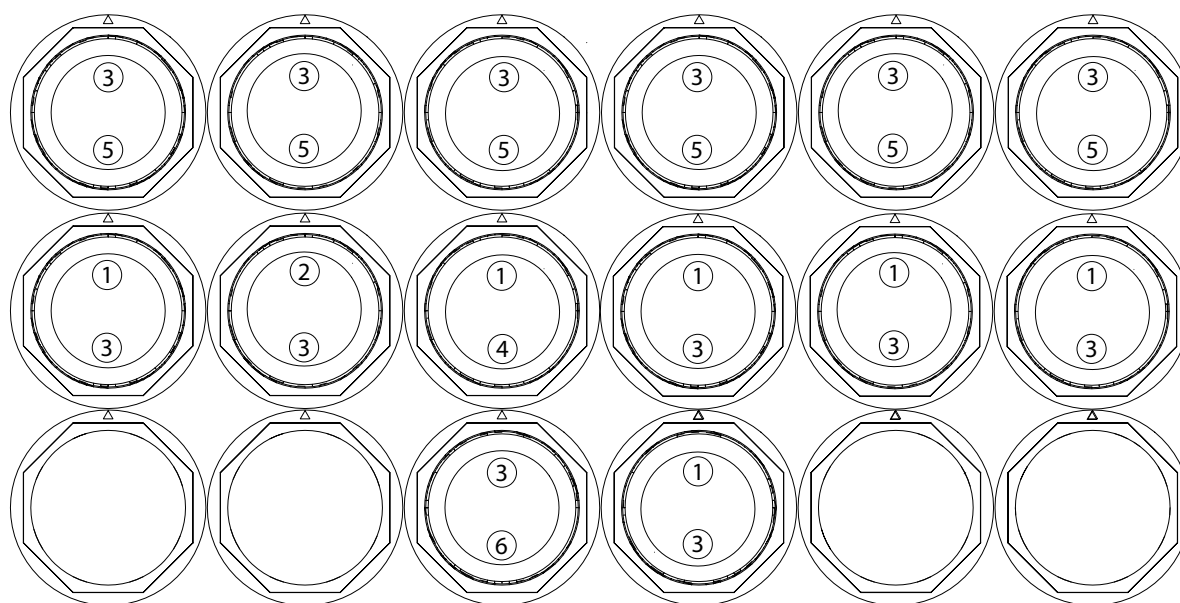

e30bf898.10

1	DC(+) plate screw	4	Midplate standoff
2	DC(+) plate standoff	5	DC(-) plate screw
3	Midplate screw	6	DC(-) plate standoff

Illustration 13.22 E1h/E3h (T5) 315 kW with 14 Capacitor Layout

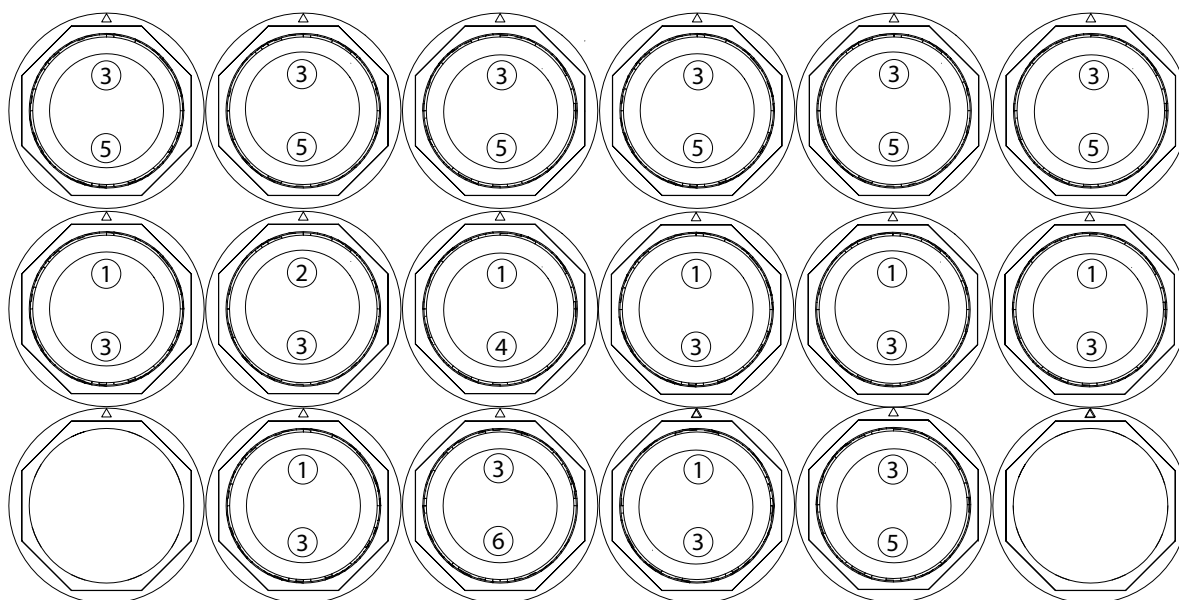

e30bf899.10

13

1	DC(+) plate screw	4	Midplate standoff
2	DC(+) plate standoff	5	DC(-) plate screw
3	Midplate screw	6	DC(-) plate standoff

Illustration 13.23 E1h/E3h (T5) 355/400 kW with 16 Capacitor Layout

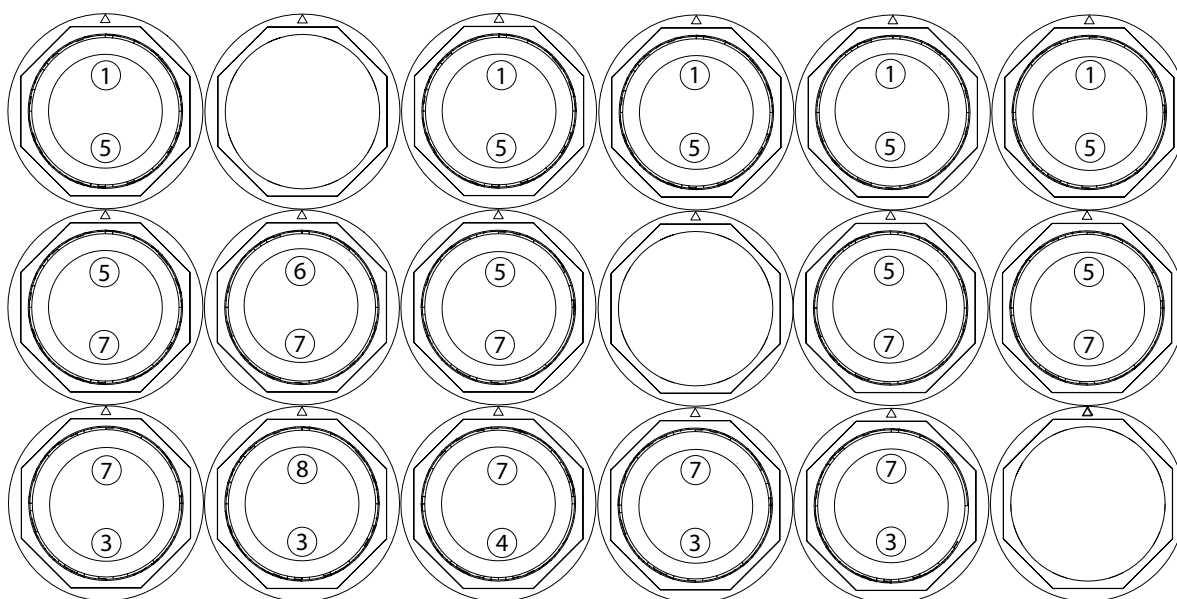

e30bf900.10

1	DC(+) plate screw	5	Midplate 1 screw
2	DC(+) plate standoff	6	Midplate 1 standoff
3	DC(-) plate screw	7	Midplate 2 screw
4	DC(-) plate standoff	8	Midplate 2 standoff

Illustration 13.24 E1h/E3h (T7) 355/400 kW with 15 Capacitor Layout

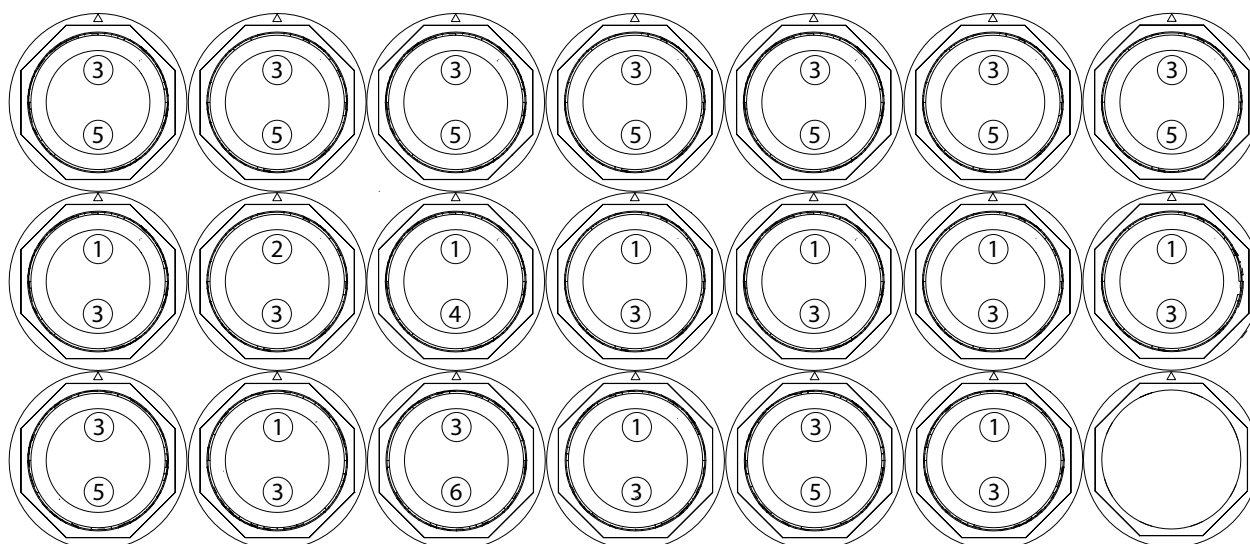

e30bf926.10

1	DC(+) plate screw	4	Midplate standoff
2	DC(+) plate standoff	5	DC(-) plate screw
3	Midplate screw	6	DC(-) plate standoff

Illustration 13.25 E2h/E4h (T5) 450/500 kW with 20 Capacitor Layout

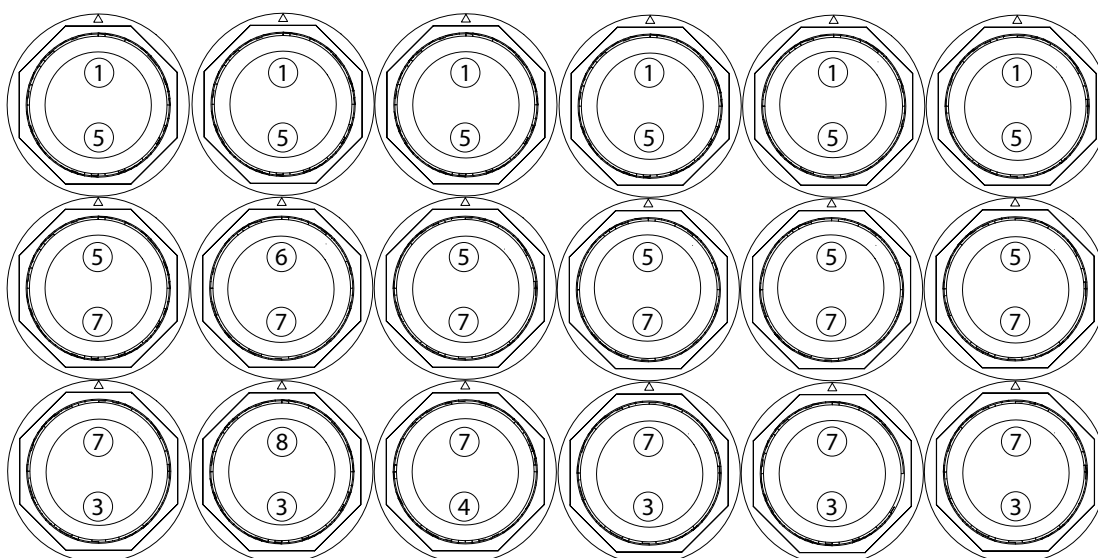

e30bf925.10

1	DC(+) plate screw	5	Midplate 1 screw
2	DC(+) plate standoff	6	Midplate 1 standoff
3	DC(-) plate screw	7	Midplate 2 screw
4	DC(-) plate standoff	8	Midplate 2 standoff

Illustration 13.26 E1h/E3h (T7) 500/560 kW with 18 Capacitor Layout

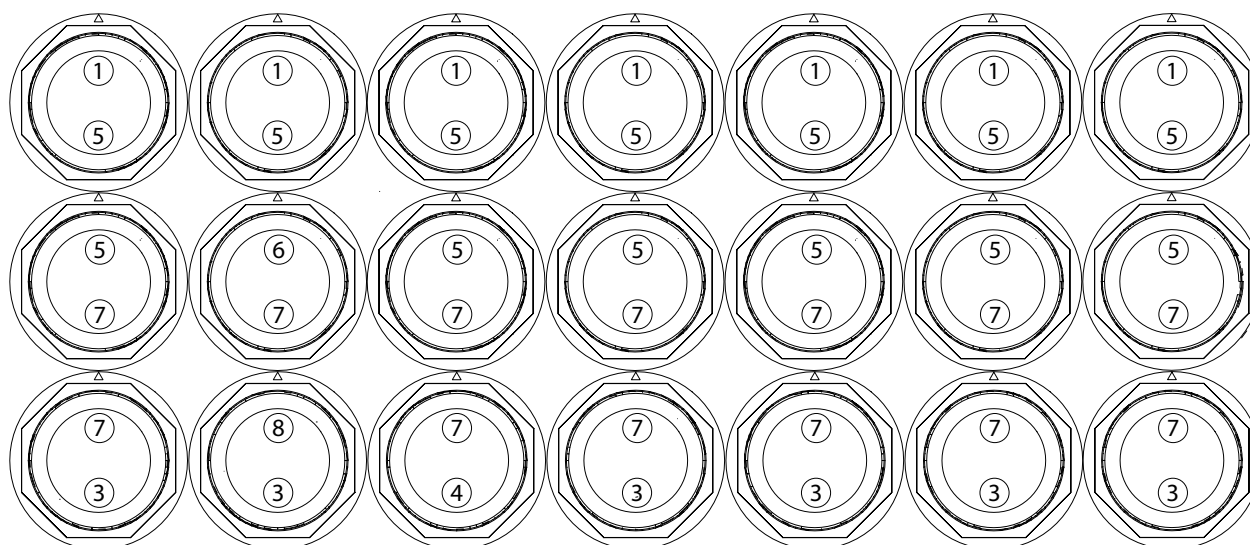

e30bf927.10

1	DC(+) plate screw	5	Midplate 1 screw
2	DC(+) plate standoff	6	Midplate 1 standoff
3	DC(-) plate screw	7	Midplate 2 screw
4	DC(-) plate standoff	8	Midplate 2 standoff

Illustration 13.27 E2h/E4h (T7) 630/710 kW with 21 Capacitor Layout

13.2.22 IGBTs

There are 6 IGBT modules in E1h–E4h drives, 2 for each phase. If the brake option is present, there are 2 brake IGBT modules as well. To remove the IGBT modules, use the following steps. Refer to *Illustration 13.28*.

Disassembly in E1h/E3h drives

1. Remove input plate. Refer to *chapter 13.2.9 Input Plate with Busbars* and *chapter 13.2.10 Split Input Plate with Options*.
2. Remove the gate drive card mounting plate. Refer to *chapter 13.2.13 Gate Drive Card Mounting Plate*.
3. Remove the DC capacitor plates and insulator sheets. See *chapter 13.2.20 Twistlock DC Capacitors*.
4. Remove the optional horizontal brake busbars, if present. Refer to *chapter 13.2.26 Horizontal Brake Busbars*.
5. Remove the Y-shaped busbars:
 - 5a Remove 12 screws (T30), 4 from each Y-shaped busbar.
 - 5b Remove 3 screws (T25), 1 from the center of each Y-shaped busbar.
 - 5c Remove the Y-shaped busbars from the drive.
6. Disconnect 2 cables from the IGBT. Disconnect 1 cable from the brake IGBT, if brake is present.
7. Remove 7 screws (T25) from each plastic IGBT mounting frame.
8. Pull the plastic IGBT mounting frame from the drive.
9. Remove 4 screws (T25) from each IGBT or brake IGBT. The number of fasteners can vary with the drive.

Reassembly in E1h/E3h drives

For reassembly, use the IGBT spare part instructions that come with the parts kit.

Disassembly in E2h/E4h drives

1. Remove the DC capacitor plates and insulator sheets. See *chapter 13.2.20 Twistlock DC Capacitors*.
2. Remove the optional horizontal brake busbars, if present. Refer to *chapter 13.2.26 Horizontal Brake Busbars*.
3. Disconnect 2 cables from the IGBT module.
4. Disconnect 1 cable from the brake IGBT module, if brake is present.
5. Remove 6 screws (T25) from each IGBT mounting frame. Remove the IGBT mounting frame from the drive.
6. Remove 10 screws (T25) from each IGBT or brake IGBT. Remove the IGBT module from the drive.

Reassembly in E2h/E4h drives

For reassembly, use the IGBT spare part instructions that come with the parts kit.

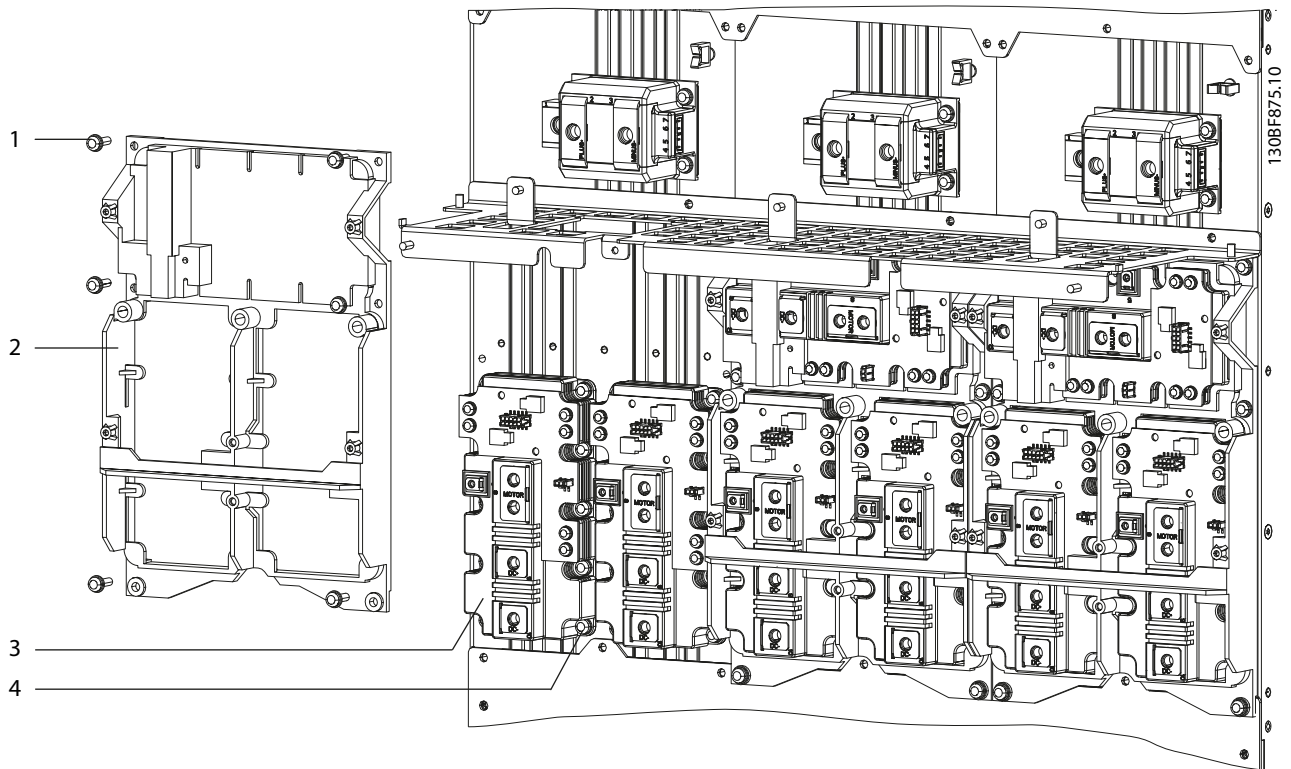

1	Screw (T25)	3	Screw (T25)
2	IGBT mounting frame	4	IGBT module

Illustration 13.28 IGBT Modules in E2h/E4h Drives (E1h/E3h is Similar)

13.2.23 Door Fan

The enclosure door includes 2 fan assemblies at the door top. To remove or reinstall a door fan, use the following steps. Refer to *Illustration 13.29*.

Disassembly

1. Pinch together the release tabs on the front grill and remove the grill from the enclosure door.
2. Remove the filter.
3. Inside the enclosure door, unplug the in-line connector attaching the fan cable.
4. Detach 4 screws (T20), 2 nuts, and 2 corner brackets from the corners of the fan. When removing the screws, hold each nut (7 mm) with a wrench on the opposite side of the fan.
5. Remove the fan from the enclosure door.

Reassembly

Tighten fasteners according to *chapter 14.1 Fastener Torque Ratings*.

1. Position the fan in the door of the enclosure with the arrow markings pointing inward.
2. On the inside of the door, replace the 2 brackets at opposite corners of the fan and secure with 2 screws (T20).
3. Replace 2 screws in the remaining 2 corners of the fan, securing each with a nut (7 mm).
4. Reconnect the in-line cable connector attaching the fan cable.
5. Replace the filter over the fan on the outside of the door.
6. Reposition fan grill over the filter and press to snap in place.

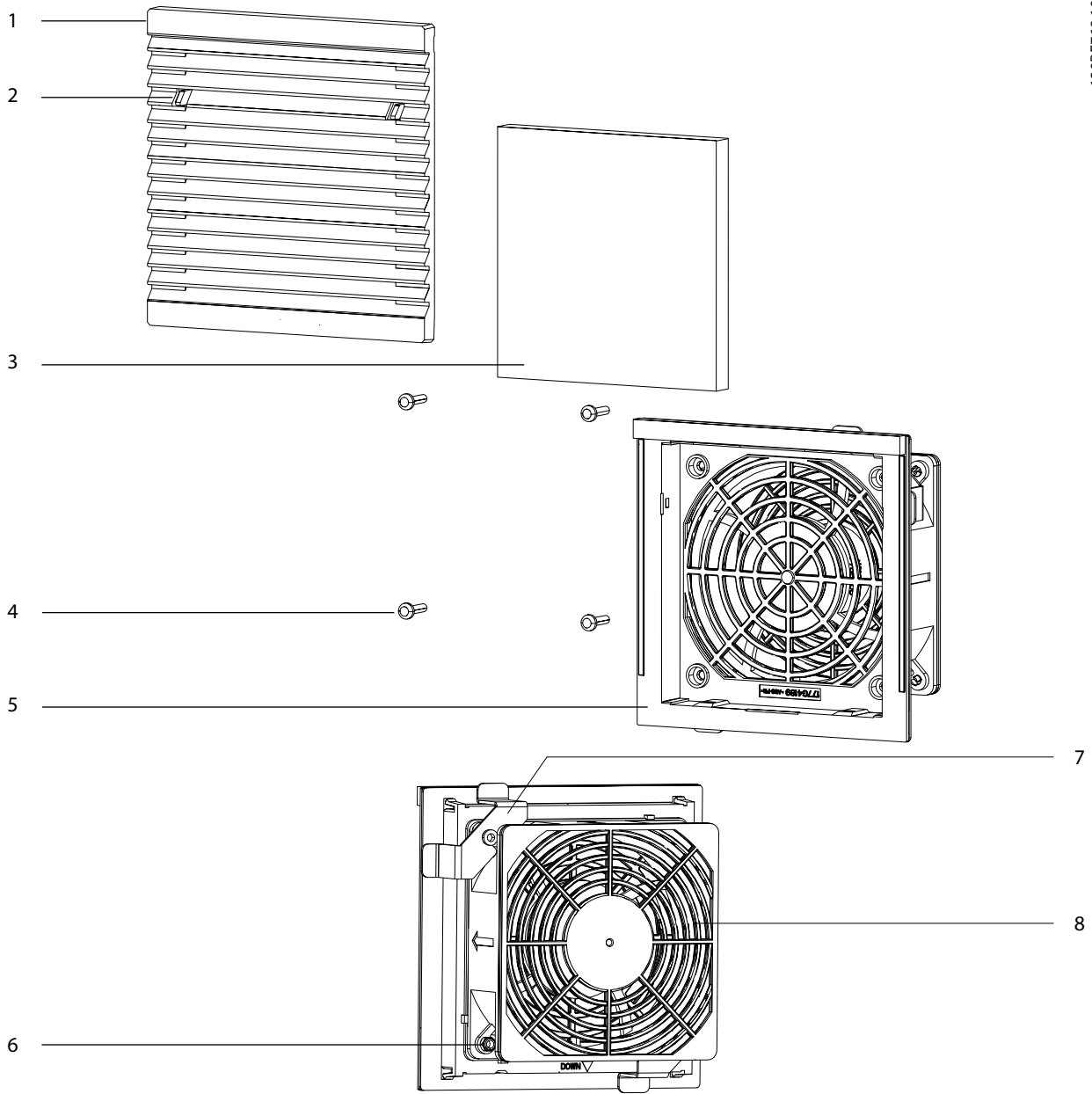

13

1	Front grill	5	Door fan front view
2	Release tab	6	Nut (7 mm)
3	Filter	7	Corner bracket
4	Screw (T20)	8	Door fan back view

Illustration 13.29 Door Fan Assembly

13.2.24 Top Fan

To remove or reinstall the top fan, use the following steps. Refer to *Illustration 13.30*.

Disassembly

1. Remove 2 screws (T25) from the fan housing.
2. Slide the fan housing and fans out from under the retaining clips.
3. Unplug the in-line connector attaching the fan cable. Feed the cable through the cable access hole.
4. Lift the fans from the pins in the fan housing.

Reassembly

Tighten fasteners according to *chapter 14.1 Fastener Torque Ratings*.

1. Place the fans over the pins in the fan housing, with the fan arrows pointing away from the drive.
2. Feed the fan cables through the cable access hole on the top plate.
3. Reconnect the in-line cable connector.
4. Slide the fan housing and fans into position under the retaining clips.
5. Secure 2 screws (T25) in the fan housing.

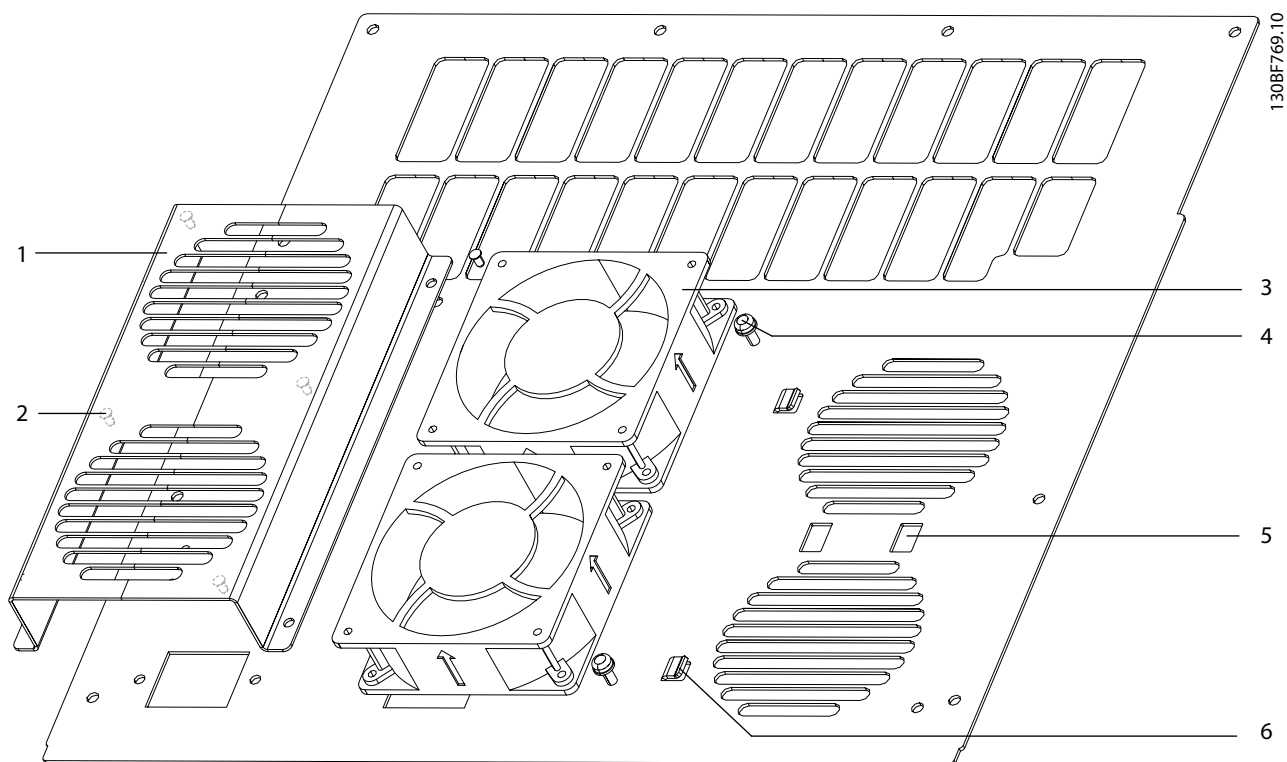

1	Fan housing	4	Screw (T25)
2	Mounting pin (inside housing)	5	Cable access hole
3	Fan	6	Retaining clip

Illustration 13.30 Top Fan

13.2.25 Vertical Brake Busbars

E1h–E4h drives can include optional brake busbars. There are 3 horizontal brake busbars and 2 vertical brake busbars. The brake busbars have a red insulated coating, which can be used to identify them. To remove or reinstall the vertical brake busbars, use the following steps. Refer to *Illustration 13.31*.

Disassembly

1. Remove the input plate. Refer to *chapter 13.2.9 Input Plate with Busbars* and *chapter 13.2.10 Split Input Plate with Options*.
2. Remove 2 screws (T40) from the bottom end of the R(-) vertical brake busbar.
3. Remove 2 screws (T40) from the top end of the R(-) vertical brake busbar. Lift the R(-) busbar from the drive.
4. Remove 2 screws (T40) from the bottom end of the R(+) vertical brake busbar.
5. Remove 2 screws (T40) from the top end of the R(+) vertical brake busbar.
6. Remove the right IGBT output busbar by removing:
 - 6a 1 screw (T25) from the middle of the right IGBT output busbar (only in E1h/E3h drives).
 - 6b 1 nut (13 mm) from the top of the right current sensor busbar.
 - 6c 2 nuts (13 mm) from the top of the right IGBT output busbar.
7. Remove 2 nuts (13 mm) from the middle of the R(+) vertical brake busbar. Lift the busbar from the drive.

Reassembly

Tighten fasteners according to *chapter 14.1 Fastener Torque Ratings*.

1. Position the R(+) vertical brake busbar in the drive. Secure 2 nuts (13 mm) in the middle of the busbar.
2. Place the right IGBT output busbar in the drive. Secure the following fasteners:
 - 2a 2 nuts (13 mm) in the top of the IGBT output busbar.
 - 2b 1 nut (13 mm) in the top of the right current sensor busbar.
 - 2c 1 screw (T25) in the middle of the right IGBT output busbar (only in E1h/E3h drives).
3. Secure 2 screws (T40) in the top end of the R(+) vertical brake busbar.
4. Secure 2 screws (T40) in the bottom end of the R(+) vertical brake busbar.
5. Position the R(-) vertical brake busbar in the drive. Secure 2 screws (T40) in the top end of the busbar.
6. Fasten 2 screws (T40) in the bottom end of the R(-) vertical brake busbar.
7. Replace the input plate. Refer to *chapter 13.2.9 Input Plate with Busbars* and *chapter 13.2.10 Split Input Plate with Options*.

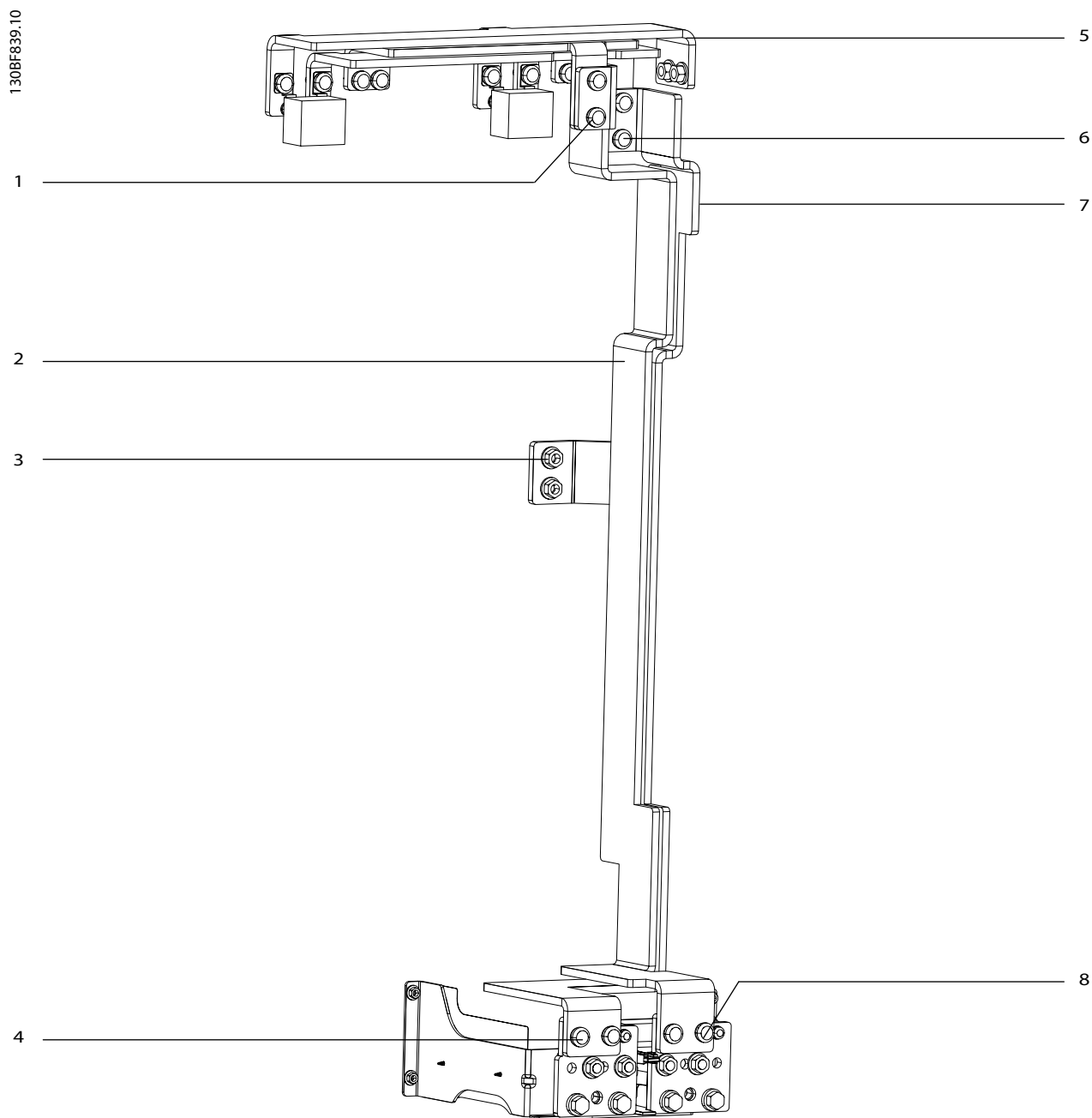

13

1	Screw (T40)	5	Horizontal brake busbars
2	R(-) vertical brake busbar	6	Screw (T40)
3	Nut (13 mm)	7	R(+) vertical brake busbar
4	Screw (T40)	8	Screw (T40)

Illustration 13.31 Brake Busbars

13.2.26 Horizontal Brake Busbars

E1h–E4h drives can include optional brake busbars. There are 3 horizontal brake busbars and 2 vertical brake busbars. The brake busbars have a red insulated coating, which can be used to identify them. To remove or reinstall the horizontal brake busbars, use the following steps.

Disassembly in E1h/E3h drives

For E1h/E3h drives, refer to *Illustration 13.32*.

1. Remove the input plate. Refer to *chapter 13.2.9 Input Plate with Busbars* and *chapter 13.2.10 Split Input Plate with Options*.
2. Remove the gate drive card mounting plate. See *chapter 13.2.13 Gate Drive Card Mounting Plate*.
3. Remove the vertical brake busbars. Refer to *chapter 13.2.25 Vertical Brake Busbars*.
4. Remove 4 screws (T40), 2 from each snubber capacitor. Remove the capacitors from the drive.
5. Remove 2 thread-forming screws (T25) from the bottom horizontal busbar. Lift the busbar from the drive.
6. Remove the middle horizontal busbar by removing:
 - 6a 4 screws (T50).
 - 6b 2 screws (T20).
7. Remove the top horizontal busbar by removing:
 - 7a 2 screws (T20).
 - 7b 2 nuts (13 mm) from the right end of the busbar.

Reassembly

Tighten fasteners according to *chapter 14.1 Fastener Torque Ratings*.

1. Position the top horizontal busbar in the drive. Secure the following fasteners:
 - 1a 2 screws (T20).
 - 1b 2 nuts (13 mm) in the right end of the busbar.
2. Position the middle horizontal busbar in the drive. Secure the following fasteners:
 - 2a 4 screws (T50).
 - 2b 2 screws (T20).
3. Position the bottom horizontal busbar in the drive. Secure 2 screws (T25) in the busbar.
4. Place the snubber capacitors in the drive. Secure 4 screws (T40), 2 in each snubber capacitor.
5. Replace the vertical brake busbars. Refer to *chapter 13.2.25 Vertical Brake Busbars*.
6. Replace the gate drive card mounting plate. See *chapter 13.2.13 Gate Drive Card Mounting Plate*.
7. Replace the input plate. Refer to *chapter 13.2.9 Input Plate with Busbars* and *chapter 13.2.10 Split Input Plate with Options*.

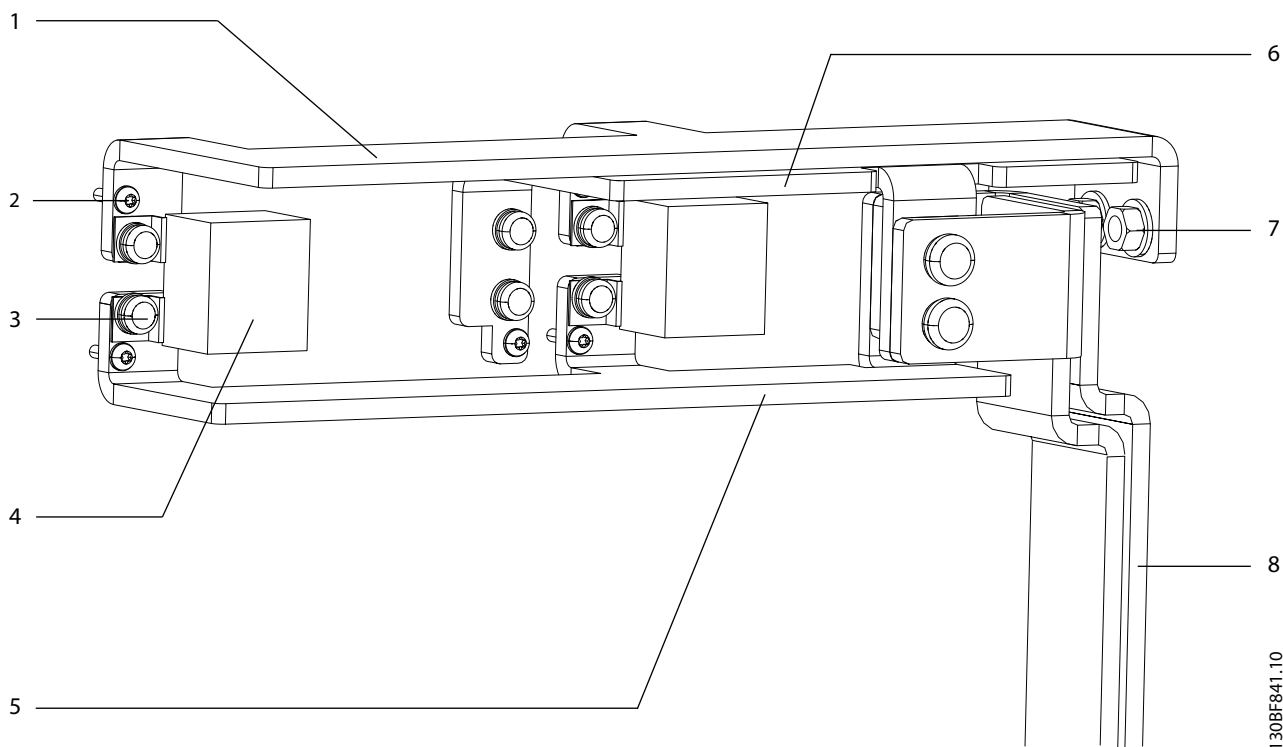

130BF841.10

1	Top horizontal brake busbar	5	Bottom horizontal brake busbar
2	Thread-forming screw (T20)	6	Middle horizontal brake busbar
3	Screw (T40)	7	Nut (13 mm)
4	Snubber capacitor	8	Vertical brake busbars

Illustration 13.32 Horizontal Brake Busbars in E1h/E3h Drives

Disassembly in E2h/E4h drives

For E2h/E4h drives, refer to *Illustration 13.33*.

1. Remove the input plate. Refer to *chapter 13.2.9 Input Plate with Busbars* and *chapter 13.2.10 Split Input Plate with Options*.
2. Remove the vertical brake busbars. Refer to *chapter 13.2.25 Vertical Brake Busbars*.
3. Remove 4 screws (T40), 2 from each snubber capacitor. Remove the capacitors from the drive.
4. Remove 2 thread-forming screws (T25) from the bottom horizontal busbar. Lift the busbar from the drive.
5. Remove 4 screws (T40) from the middle horizontal busbar. Remove the busbar from the drive.
6. Remove the top horizontal busbar by removing:
 - 6a 2 thread-forming screws (T25).
 - 6b 2 nuts (13 mm) from the right end of the busbar.

Reassembly in E2h/E4h drives

Tighten fasteners according to *chapter 14.1 Fastener Torque Ratings*.

1. Position the top horizontal busbar in the drive, and replace the following fasteners:
 - 1a 2 thread-forming screws (T25).
 - 1b 2 nuts (13 mm) in the right end of the busbar.
2. Position the middle horizontal busbar in the drive. Secure 4 screws (T40).
3. Position the bottom horizontal busbar in the drive. Secure 2 thread-forming screws (T25).
4. Position 2 snubber capacitors in the drive. Fasten 4 screws (T40), 2 in each snubber capacitor.
5. Replace the vertical brake busbars. Refer to *chapter 13.2.25 Vertical Brake Busbars*.
6. Replace the input plate. Refer to *chapter 13.2.9 Input Plate with Busbars* and *chapter 13.2.10 Split Input Plate with Options*.

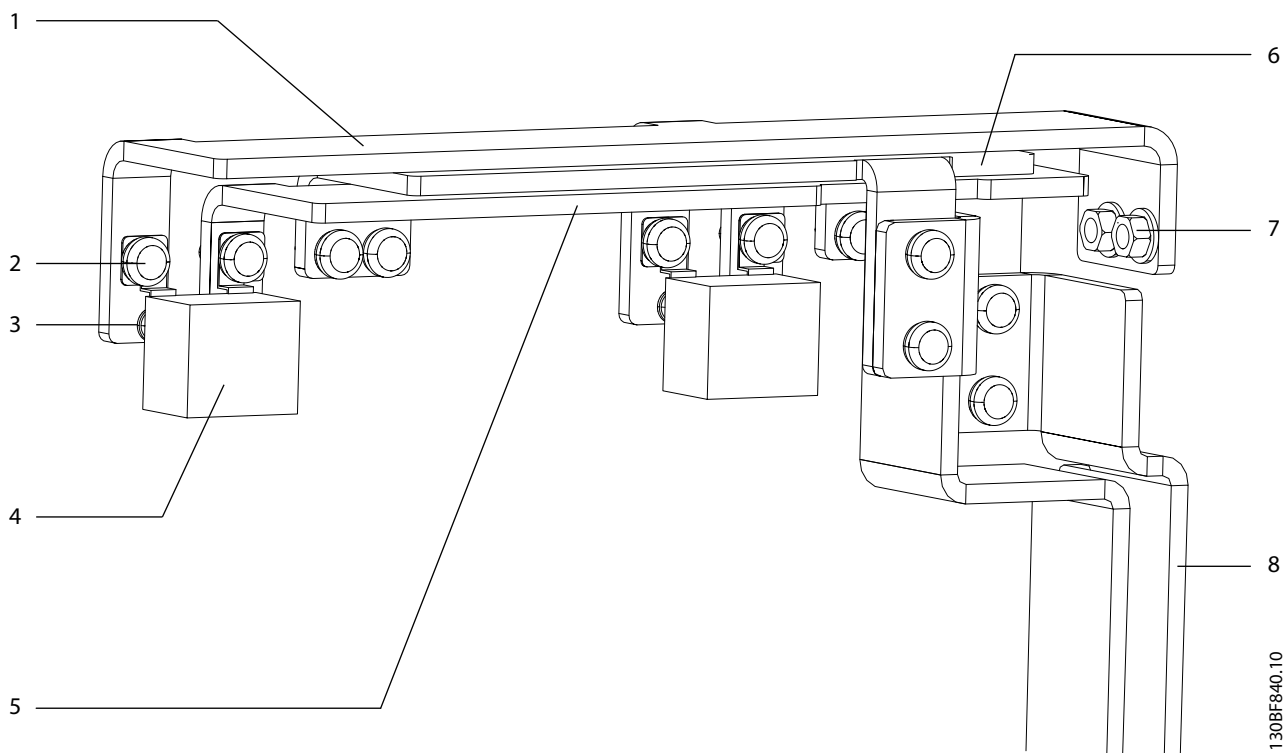

1	Top horizontal brake busbar	5	Bottom horizontal brake busbar
2	Screw (T40)	6	Middle horizontal brake busbar
3	Thread-forming screw (T25) (behind snubber capacitor)	7	Nut (13 mm)
4	Snubber capacitor	8	Vertical brake busbars

Illustration 13.33 Horizontal Brake Busbars in E2h/E4h Drives

13.2.27 DC Bus Rails

The DC bus rails run from the inductor to the capacitor bank on the right and left sides of E1h–E4h drives. To remove or reinstall the DC bus rails, use the following steps. Refer to *Illustration 13.34*.

Disassembly

1. Remove the power card mounting plate. Refer to *chapter 13.2.3 Power Card Mounting Plate*.
2. Remove the input plate. Refer to *chapter 13.2.9 Input Plate with Busbars* and *chapter 13.2.10 Split Input Plate with Options*.
3. If the brake option is present, remove the vertical brake busbars. See *chapter 13.2.25 Vertical Brake Busbars*.
4. Remove the left and right IGBT output busbars. Refer to *chapter 13.2.15 Current Sensors*.
5. To remove the right DC(-) bus rail:
 - 5a Remove 2 nuts (13 mm) from the bottom of the bus rail.
 - 5b If the optional brake is present, remove 2 nuts (13 mm) from the middle of the bus rail.
 - 5c Remove 1 screw (T40) from the top of the bus rail.
 - 5d Remove 2 screws (T25) from the top of the bus rail.
 - 5e Lift the right DC(-) bus rail from the unit.
6. To remove the left DC(+) bus rail:
 - 6a Remove 2 nuts (13 mm) from the bottom of the bus rail.
 - 6b Remove 1 screw (T40) from the top of the bus rail.
 - 6c Remove 2 screws (T25) from the top of the bus rail.
 - 6d Remove the zip ties connecting the cables to the bus rail.
 - 6e Lift the left DC(+) bus rail from the unit.

Reassembly

Tighten fasteners according to *chapter 14.1 Fastener Torque Ratings*.

1. To replace the left DC(+) bus rail:
 - 1a Position the left DC(+) bus rail in the drive, and fasten 2 screws (T25) at the top of the bus rail.
 - 1b Secure 1 screw (T40) at the top of the bus rail.
 - 1c Secure 2 nuts (13 mm) at the bottom of the bus rail.
2. To replace the right DC(-) bus rail:
 - 2a Position the right DC(-) bus rail in the drive, and fasten 2 screws (T25) at the top of the bus rail.
 - 2b Secure 1 screw (T40) at the top of the bus rail.
 - 2c If the optional brake is present, secure 2 nuts (13 mm) in the middle of the bus rail.
 - 2d Secure 2 nuts (13 mm) in the bottom of the bus rail.
3. Replace the left and right IGBT output busbars. Refer to *chapter 13.2.15 Current Sensors*.
4. If the brake option is present, replace the vertical brake busbars. See *chapter 13.2.25 Vertical Brake Busbars*.
5. Replace the input plate. Refer to *chapter 13.2.9 Input Plate with Busbars* and *chapter 13.2.10 Split Input Plate with Options*.
6. Replace the power card mounting plate. Refer to *chapter 13.2.3 Power Card Mounting Plate*.

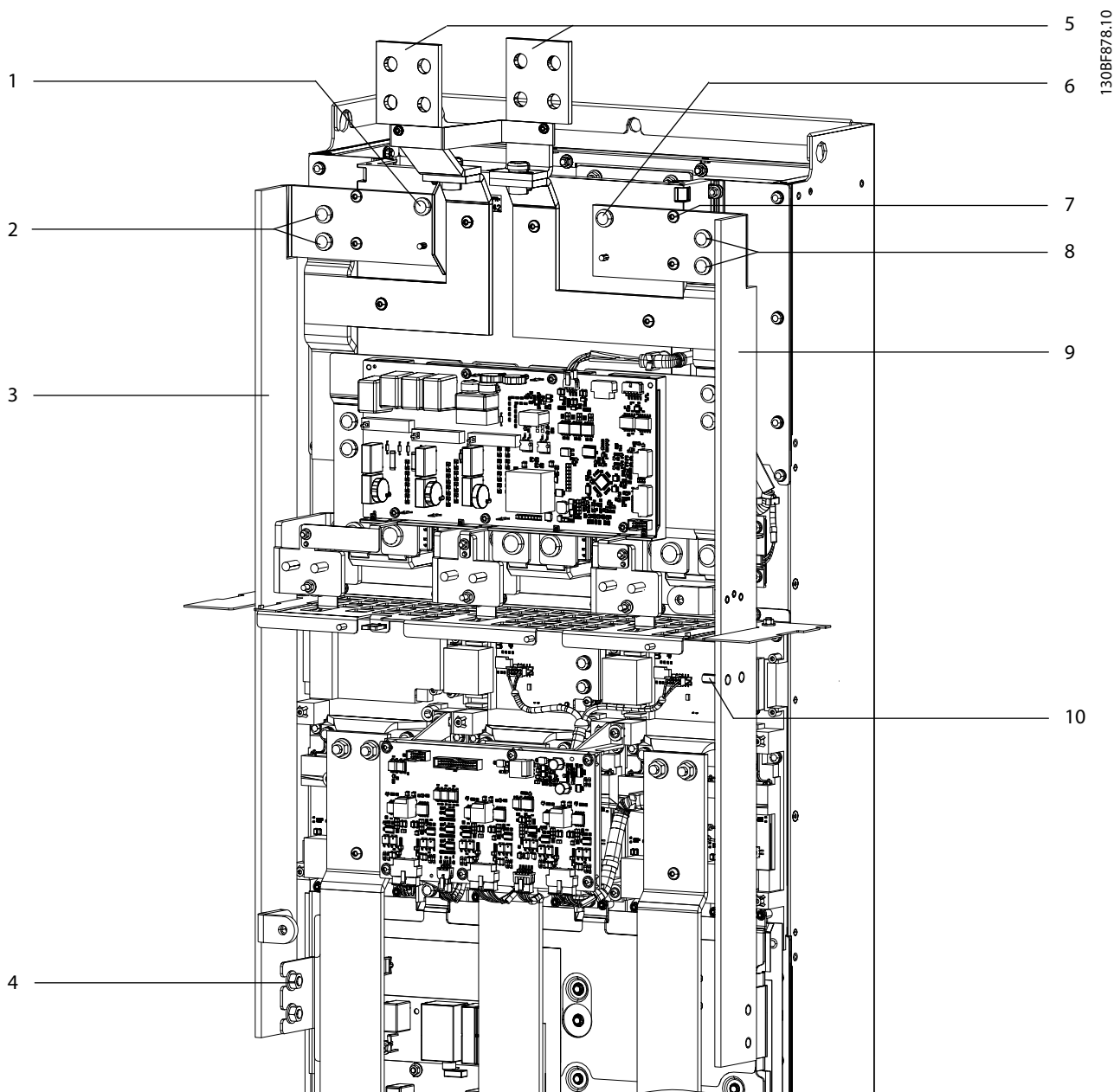

13

1	Screw (T40) in DC(+) bus rail	6	Screw (T40) in DC(-) bus rail
2	Screws (T40) only with optional regen terminals	7	Screw (T25)
3	DC(+) bus rail (left)	8	Screws (T40) only with optional regen terminals
4	Nut (13 mm)	9	DC(-) bus rail (right)
5	Regen terminals (optional)	10	Nut (13 mm) for optional brake

Illustration 13.34 DC Bus Rails

14 Product Specifications

14.1 Fastener Torque Ratings

14.1.1 General Torque Tightening Values

Use a torque wrench to ensure that correct torque is applied. Incorrect torque can cause electrical connection problems. For fastening hardware described in this guide, use the values listed in *Table 14.1* to *Table 14.3*.

NOTICE

TORQUE VALUES

The torque values in the following tables are not intended for SCR, diode, or IGBT fasteners. Refer to the instructions included with those replacement parts for correct values.

Shaft size	Torx/hex drives size	Class A Nm (in-lb)	Class B Nm (in-lb)
M4	T20/7 mm	1.2 (10)	0.8 (7)
M5	T25/8 mm	2.3 (20)	1.2 (10)
M6	T30/10 mm	3.9 (35)	2.3 (20)
M8	T40/13 mm	9.6 (85)	3.9 (35)
M10	T50/17 mm	19.1 (169)	9.6 (85)
M12	-/18 mm or 19 mm	37.9 (335)	-

Table 14.1 Torque Values Standard Thread

Shaft size	Torx drives size	Class A Nm (in-lb)	Class B Nm (in-lb)
M4.8	T25	5.7 (50)	3.1 (27)
M5	T25	1.7 (15)	1.7 (15)

Table 14.2 Torque Values for Thread-cutting into Metal

Shaft size	Torx drives size	Class A Nm (in-lb)	Class B Nm (in-lb)
M4	T20	2.8 (24)	2.8 (24)
M5	T25	5.1 (45)	4.0 (35)

Table 14.3 Torque Values for Thread-forming into Plastic

Class A: Clamping metal

Class B: Clamping PCA or plastic

14.1.2 Unique Torque Values in E1h–E4h Drives

Some fasteners in E1h–E4h drives require unique, non-standard torque values. Refer to *Illustration 14.1* for the type and location of these fasteners.

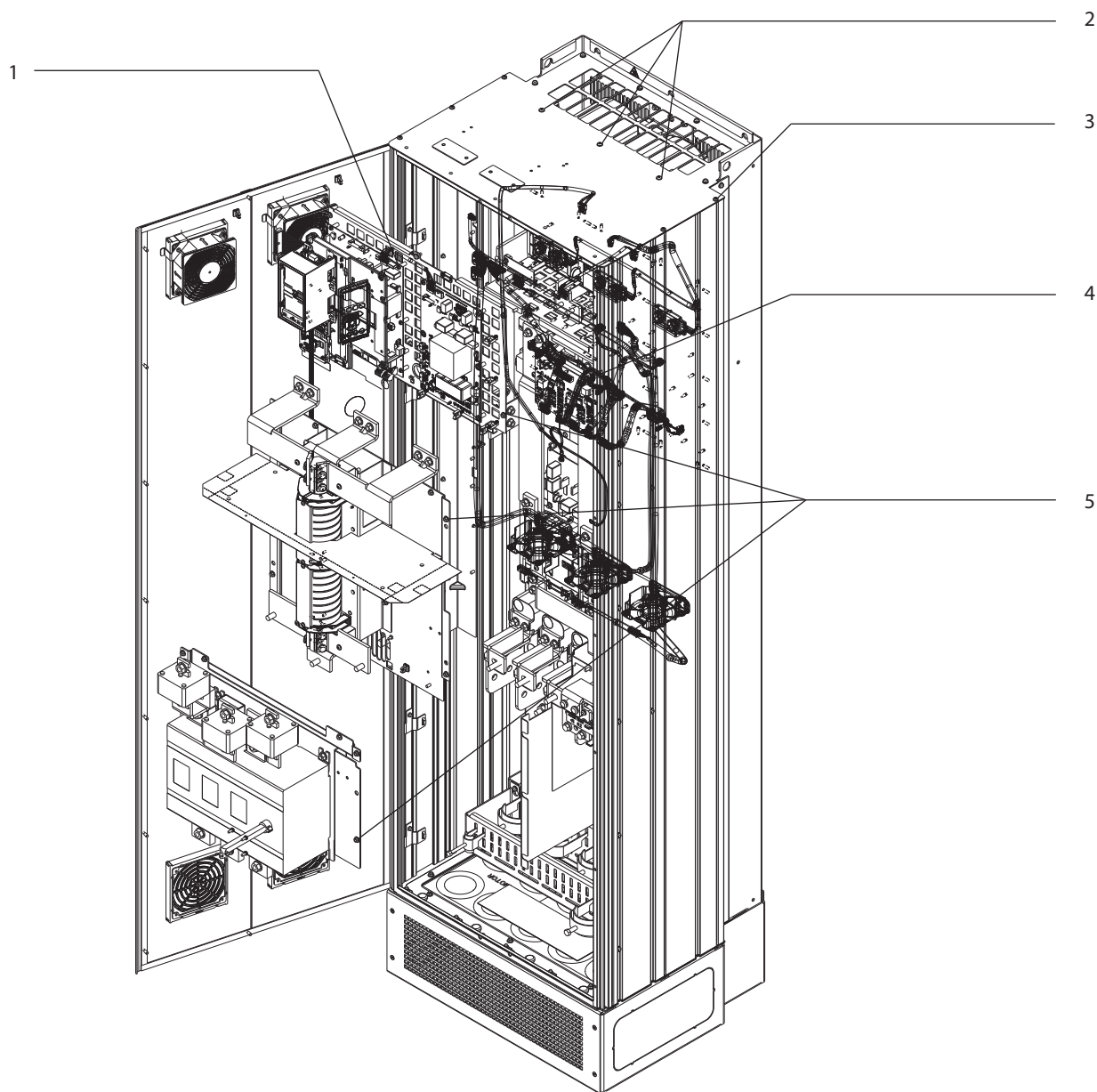

14

130BF930.10

1	All M4 fasteners Torque: 2.27 Nm (20.1 lb-in)	4	6 M5 fasteners attaching gate drive card Torque: 2.27 Nm (20.1 lb-in)
2	3 M5 fasteners Torque: 3.91 Nm (34.6 lb-in)	5	All M5 fasteners attaching input plates to side mounting rail Torque: 3.91 Nm (34.6 lb-in)
3	All gasketed M5 fasteners except door screws Torque: 3.91 Nm (34.6 lb-in)	–	–

Illustration 14.1 Unique Torque Values, E1h–E4h Drives

14.2 DC Voltage Levels

FC 102/FC 103/FC 202/FC 302	200–240 V units		380–480/500 V units		525–690 V units
Inrush circuit enabled [V DC]	182		370		550
Inrush circuit disabled [V DC]	198		395		570
Inverter undervoltage disable [V DC]	185		373		553
Undervoltage warning [V DC]	205		410		585
Inverter undervoltage re-enable (warning reset) [V DC]	201		413		602
			380–480 V units	380–500 V units	525–690 V units
Overtoltage warning (without brake) [V DC]	390		778	817	1084
Dynamic brake turn on [V DC]	–		778	810	1099
Inverter overvoltage re-enable (warning reset) [V DC]	395		786	821	1099
Overtoltage warning (with brake) [V DC]	–		810	828	1109
Overtoltage trip [V DC]	410		820	855	1130

Table 14.4 DC Voltage Levels

14.3 Warning and Alarm Trips Points

200–240 V AC	FC 102/FC 103/ FC 202	N55K	N75K	N90K	N110	N150	N160
200–240 V AC	FC 302	N45K	N55K	N75K	N90K	N110	N150
Overcurrent warning	[A _{rms}]	296	352	444	559	668	820
Overcurrent alarm ¹⁾ (1.5 s delay)	[A _{rms}]	299	355	447	562	671	823
Earth (ground) fault alarm	[A _{rms}]	24	29	36	45	54	66
Short circuit alarm	[A _{pk}]	711	868	1051	1051	1318	1595
Heat sink overtemperature	[°C]	110	110	110	110	110	110
Heat sink undertemperature warning	[°C]	0	0	0	0	0	0
Control card overtemperature	[°C]	75	75	80	80	80	80
Mains phase warning (30 s delay)	DC bus ripple V _{pkpk}	80	80	80	80	80	80
Mains phase alarm (60 s delay)	DC bus ripple V _{pkpk}	80	80	80	80	80	80

Table 14.5 Warning/Alarm Trip Points, D1h–D4h Drives, 200–240 V AC

380–480 V AC	FC 102/FC 103/ FC 202	N110	N132	N160	N200	N250	N315
380–500 V AC	FC 302	N90K	N110	N132	N160	N200	N250
Overcurrent warning	[A _{rms}]	327	392	481	583	731	888
Overcurrent alarm ¹⁾ (1.5 s delay)	[A _{rms}]	330	395	483	585	734	893
Earth (ground) fault alarm	[A _{rms}]	27	32	39	47	59	72
Short circuit alarm	[A _{pk}]	593	711	868	1051	1318	1595
Heat sink overtemperature	[°C]	110	110	110	110	110	110
Heat sink undertemperature warning	[°C]	0	0	0	0	0	0
Control card overtemperature	[°C]	75	75	75	80	80	80
Mains phase warning (30 s delay)	DC bus ripple V _{pkpk}	80	80	80	80	80	80
Mains phase alarm (60 s delay)	DC bus ripple V _{pkpk}	80	80	80	80	80	80

Table 14.6 Warning/Alarm Trip Points, D-sized Drives, 380–480/500 V AC

1) Based on crest factor of 1.414

525–690 V AC	FC 102/FC 103/ FC 202	N75	N90	N110	N132	N160	N200	N250	N315	N400
	FC 302	N55	N75	N90	N110	N132	N160	N200	N250	N315
Overcurrent warning	[A _{rms}]	141	167	209	253	300	372	468	561	666
Overcurrent alarm ¹⁾ (1.5 s delay)	[A _{rms}]	255	255	255	255	330	483	483	585	734
Earth (ground) fault alarm	[A _{rms}]	11	14	17	21	24	30	38	45	54
Short circuit alarm	[A _{pk}]	459	459	459	459	593	870	869	1050	1319
Heat sink overtemperature	[°C]	110	110	110	110	110	110	110	110	110
Heat sink undertemperature warning	[°C]	0	0	0	0	0	0	0	0	0
Control card overtemperature	[°C]	75	75	75	75	75	75	80	80	80
Mains phase warning (30 s delay)	DC bus ripple V _{pkpk}	80	80	80	80	80	80	80	80	80
Mains phase alarm (60 s delay)	DC bus ripple V _{pkpk}	80	80	80	80	80	80	80	80	80

Table 14.7 Warning and Alarm Trip Points, D-sized Drives, 525–690 VAC
1) Based on crest factor of 1.414

380–480 V AC	FC 102/FC 103/FC 202	N355	N400	N450	N500	N560
	FC 302	N315	N355	N400	N450	N500
Heat sink overtemperature trip	[°C (°F)]	110 (230)	110 (230)	110 (230)	110 (230)	100 (212)
Control card overtemperature trip	[°C (°F)]	80 (176)	80 (176)	80 (176)	80 (176)	80 (176)
Power card overtemperature trip	[°C (°F)]	85 (185)	85 (185)	85 (185)	85 (185)	85 (185)
Fan power card overtemperature trip	[°C (°F)]	85 (185)	85 (185)	85 (185)	85 (185)	85 (185)
Active in-rush card overtemperature trip	[°C (°F)]	85 (185)	85 (185)	85 (185)	85 (185)	85 (185)

Table 14.8 Warning/Alarm Trip Points, E-sized Drives, 380–500 V AC

525–690 V AC	FC 102/FC 103/FC 202	N450	N500	N560	N630	N710	N800
	FC 302	N355	N400	N500	N560	N630	N710
Heat sink overtemperature trip	[°C (°F)]	110 (230)	110 (230)	110 (230)	110 (230)	110 (230)	110 (230)
Control card overtemperature trip	[°C (°F)]	80 (176)	80 (176)	80 (176)	80 (176)	80 (176)	80 (176)
Power card overtemperature trip	[°C (°F)]	85 (185)	85 (185)	85 (185)	85 (185)	85 (185)	85 (185)
Fan power card overtemperature trip	[°C (°F)]	85 (185)	85 (185)	85 (185)	85 (185)	85 (185)	85 (185)
Active inrush card overtemperature trip	[°C (°F)]	85 (185)	85 (185)	85 (185)	85 (185)	85 (185)	85 (185)

Table 14.9 Warning and Alarm Trip Points, E-sized Drives, 525–690 V AC

15 Spare Parts

BUSBAR REPLACEMENT

Busbars used in some units are aluminum. Spare part busbars are plated copper when available. Plated copper busbars are useable for all units.

To find spare part numbers and descriptions, use either of these methods:

- Use the *Drive Configurator* on the Danfoss website.
- See the spare parts lists in this chapter.

NOTICE

PARTS LIST DETAILS

The parts numbers listed in the following tables are current at the time of publication. Updated spare parts information can be found with the *Drive Configurator*.

All spare parts are suitable for conformal coated drives and can be used in either coated or non-conformal coated drives.

15.1.1 Using the Drive Configurator Tool

For the latest spare parts information, visit the Danfoss website using the following directions.

1. Go to <https://vltconfig.danfoss.com/>.
2. Under *Configurable Products*, select the product. The product is listed on the product label and in the first 5 digits of the type code (T/C). See *chapter 3.4 Enclosure Size Identification*.
3. Under *Configure by Type Code*, enter the type code from the drive label and click *Configure*. Alternatively, select the drive features in the required fields and click *Accept*.
4. Check the *Configuration Details* tab to confirm that it matches the unit.
5. Select the *Accessories* tab or *DrivePro* tab to display spare parts and kits.
6. Use the right arrow to scroll through the parts list to find the spare part.

Click the part number for a detailed description of the part. The *Drive Configurator* is under development and subject to change. For additional information on spare parts, contact Danfoss.

15.1.2 Spare Parts Lists

This section includes the following tables for referencing spare part numbers:

- Recommended Current Scaling Cards
- Spare Parts List, D1h–D4h, 200–240 V AC (T2)
- Spare Parts List, D1h–D8h, 380–480/500 V AC (T4/T5)
- Spare Parts List, D1h–D8h, 525–690 V AC (T7)
- Spare Parts List, E1h–E4h Drives, 380–480/500 V AC (T4/T5)
- Spare Parts List, E1h–E4h Drives, 525–690 V AC (T7)

15.1.3 Recommended Current Scaling Cards

FC 102/FC 103/FC 202	FC 302	Current scaling card	Part number
N55K	N45K	3.8 Ω	176F3154
N75K	N55K	3.1 Ω	176F3155
N90K	N75K	2.6 Ω	176F3156
N110	N90K	2.6 Ω	176F3156
N150	N110	5.1 Ω	176F3157
N160	N150	4.2 Ω	176F3158

Table 15.1 Recommended Current Scaling Cards, D1h–D4h Drives, 200–240 V (T2)

FC 102/FC 103/FC 202	FC 302	Current scaling card	Part number
N110	N90K	4.6 Ω	176F3153
N132	N110	3.8 Ω	176F3154
N160	N132	3.1 Ω	176F3155
N200	N160	2.6 Ω	176F3156
N250	N200	5.1 Ω	176F3157
N315	N250	4.2 Ω	176F3158

Table 15.2 Recommended Current Scaling Cards, D1h–D8h Drives, 380–480/500 V (T4/T5)

FC 102/FC 103/FC 202	FC 302	Current scaling card	Part number
N75K	N55K	5.9 Ω	176F3411
N90K	N75K	5.9 Ω	176F3411
N110	N90K	5.9 Ω	176F3411
N132	N110	5.9 Ω	176F3411
N160	N132	5.0 Ω	176F3412
N200	N160	4.0 Ω	176F3413
N250	N200	3.2 Ω	176F3414
N315	N250	2.7 Ω	176F3415
N400	N315	5.6 Ω	176F3416

Table 15.3 Recommended Current Scaling Cards, D1h–D8h Drives, 525–690 V (T7)

FC 102/FC 103/FC 202	FC 302	Drive module	Current scaling card	Part number
N315	N250	N160T5	2.6 Ω	176F3156
N355	N315	N200T5	5.1 Ω	176F3157
N400	N355	N200T5	5.1 Ω	176F3157
N450	N400	N250T5	4.2 Ω	176F3158
N500	N450	N250T5	4.2 Ω	176F3158
N560	N500	N160T5	2.6 Ω	176F3156
N630	N560	N200T5	5.1 Ω	176F3157
N710	N630	N200T5	5.1 Ω	176F3157
N800	N710	N250T5	4.2 Ω	176F3158
N1M0	N800	N250T5	4.2 Ω	176F3158

Table 15.4 Recommended Current Scaling Cards, Parallel Drive Systems and Parallel Drive Modules, 380–500 V (T5)

FC 102/FC 103/FC 202	FC 302	Drive module	Current scaling card	Part number
N315	N250	N160T7	4.0 Ω	176F3413
N355	N315	N200T7	3.2 Ω	176F3413
N400	N355	N200T7	3.2 Ω	176F3414
N450	N400	N250T7	2.7 Ω	176F3413
N500	N450	N250T7	5.6 Ω	176F3415
N560	N500	N315T7	5.6 Ω	176F3416
N630	N560	N315T7	3.2 Ω	176F3416
N710	N630	N200T7	2.7 Ω	176F3415
N800	N710	N250T7	2.7 Ω	176F3415
N1M0	N800	N315T7	5.6 Ω	176F3416
N1M2	N1M0	N315T7	5.6 Ω	176F3416

Table 15.5 Recommended Current Scaling Cards, Parallel Drive Systems and Parallel Drive Modules, 525–690 V (T7)

FC 102/FC 103/FC 202	FC 302	Current scaling card	Part number
N355	N315	2.7 Ω	176F3415
N400	N355	2.5 Ω	176F6628
N450	N400	2.3 Ω	176F6629
N500	N450	2.0 Ω	176F6630
N560	N500	1.8 Ω	176F6631

Table 15.6 Recommended Current Scaling Cards, E1h–E4h Drives, 380–500 V (T5)

FC 102/FC 103/FC 202	FC 302	Current scaling card	Part number
N450	N400	4.0 Ω	176F3413
N500	N450	3.8 Ω	176F3154
N560	N500	3.1 Ω	176F3155
N630	N560	2.7 Ω	176F3415
N710	N630	2.5 Ω	176F6628
N800	N710	2.1 Ω	176F6632

Table 15.7 Recommended Current Scaling Cards, E1h–E4h Drives, 525–690 V (T7)

Block Diagram Name	Spare Part Number	Spare Part Name	Comments	200-240 V AC																	
				D1h/D3h				D2h/D4h													
				FC 102 (T2)	N55K	N75K	N90K	N100	N150	N160	N100	N150	N160								
Control Cards																					
PCA1	130B1151	Control Card, FC 102	coated, no safe stop	102	102	102	102	102	102	102	102	102	102	102	102						
PCA1	134B1730	Control Card, FC 102	coated, no safe stop, Ver 2 card	102	102	102	102	102	102	102	102	102	102	102	102						
PCA1	130B1150	Control Card, FC 102	coated, safe stop	102	102	102	102	102	102	102	102	102	102	102	102						
PCA1	134B1729	Control Card, FC 102	coated, safe stop, Ver 2 card	102	102	102	102	102	102	102	102	102	102	102	102						
PCA1	130B6968	Control Card, FC 103	coated, no safe stop	103	103	103	103	103	103	103	103	103	103	103	103						
PCA1	134B1724	Control Card, FC 103	coated, no safe stop, Ver 2 card	103	103	103	103	103	103	103	103	103	103	103	103						
PCA1	130B6967	Control Card, FC 103	coated, safe stop	103	103	103	103	103	103	103	103	103	103	103	103						
PCA1	134B1714	Control Card, FC 103	coated, safe stop, Ver 2 card	103	103	103	103	103	103	103	103	103	103	103	103						
PCA1	130B1168	Control Card, FC 202	coated, no safe stop	202	202	202	202	202	202	202	202	202	202	202	202						
PCA1	134B1732	Control Card, FC 202	coated, no safe stop, Ver 2 card	202	202	202	202	202	202	202	202	202	202	202	202						
PCA1	130B1167	Control Card, FC 202	coated, safe stop	202	202	202	202	202	202	202	202	202	202	202	202						
PCA1	134B1731	Control Card, FC 202	coated, safe stop, Ver 2 card	202	202	202	202	202	202	202	202	202	202	202	202						
PCA1	130B1128	Control Card, FC 301	coated, no safe stop	301	301	301	301	301	301	301	301	301	301	301	301						
PCA1	134B1728	Control Card, FC 301	coated, no safe stop, Ver 2 card	301	301	301	301	301	301	301	301	301	301	301	301						
PCA1	130B1126	Control Card, FC 301	coated, safe stop	301	301	301	301	301	301	301	301	301	301	301	301						
PCA1	134B1727	Control Card, FC 301	coated, safe stop, Ver 2 card	301	301	301	301	301	301	301	301	301	301	301	301						
PCA1	130B1109	Control Card, FC 302	coated, safe stop	302	302	302	302	302	302	302	302	302	302	302	302						
PCA1	134B1726	Control Card, FC 302	coated, safe stop, Ver 2 card	302	302	302	302	302	302	302	302	302	302	302	302						
Power Cards																					
PCA2	176F3832	Power Card NO 55kW 200-240V	Power card, conformal coated, does not incl scaling card	T2	-	-	-	-	-	-	-	-	-	-	-						
PCA2	176F3834	Power Card NO 75kW 200-240V	Power card, conformal coated, does not incl scaling card	-	T2	-	-	-	-	-	-	-	-	-	-						
PCA2	176F3835	Power Card NO 90kW 200-240V	Power card, conformal coated, does not incl scaling card	-	-	T2	-	-	-	-	-	-	-	-	-						
PCA2	176F3836	Power Card NO 110kW 200-240V	Power card, conformal coated, does not incl scaling card	-	-	-	T2	-	-	-	-	-	-	-	-						
PCA2	176F3837	Power Card NO 150kW 200-240V	Power card, conformal coated, does not incl scaling card	-	-	-	-	-	-	-	T2	-	-	-	-						
PCA2	176F3838	Power Card NO 160kW 200-240V	Power card, conformal coated, does not incl scaling card	-	-	-	-	-	-	-	-	-	-	-	T2						
Other Printed Circuit Cards																					
PCA3	176F3154	Current scaling card 3.82 OHM 400V	Installs on the power card	1	-	-	-	-	-	-	-	-	-	-	-						
PCA3	176F3155	Current scaling card 3.11 OHM 400V	Installs on the power card	-	1	-	-	-	-	-	-	-	-	-	-						
PCA3	176F3156	Current scaling card 2.56 OHM 400V	Installs on the power card	-	-	1	-	-	-	-	-	-	-	-	-						
PCA3	176F3156	Current scaling card 2.56 OHM 400V	Installs on the power card	-	-	-	-	1	-	-	-	-	-	-	-						
PCA3	176F3157	Current scaling card 5.10 OHM 400V	Installs on the power card	-	-	-	-	-	-	-	-	1	-	-	-						

Block Diagram Name	Spare Part Number	Spare Part Name	Comments	200-240 V AC														
				D1h/D3h						D2h/D4h								
				FC 102 (T2)	N55K	N75K	N90K	N100	N150	N160	FC 202 (T2)	N55K	N75K	N90K	N100	N150	N160	
PCA3	176F3158	Current scaling card 4.22 OHM 400V	Installs on the power card															
PCA4	176F3833	Inrush card NO 55-160KW 200V	Soft-charge / inrush card															
PCA5	176F3160	Gate drive card NO 110-315KW 400V	Gate drive card															
PCA6	176F3387	RFI card NO 110-315KW 400V	RFI class A1 board															
PCA7	176F3161	Balance/HF card NO 110-315KW 400V	DC Bus Cap Balance / High Freq card															
Semiconductors																		
SCR 1,2,3	176F3337	Rectifier SCR/diode 503A 1600V	1 SCR/Diode per kit - See product note 185															
SCR 1,2,3	176F8318	Rectifier SCR/diode 175A 1600V	1 SCR/Diode per kit															
SCR 1,2,3	176F8320	Rectifier SCR/diode 330A 1600V	1 SCR/Diode per kit. Incl 1 standoff to inrush bd-177G4369															
IGBT 1,2,3	176F3362	IGBT dual module 300A 1200V	1 IGBT per kit															
IGBT 1,2,3	176F3363	IGBT dual module 450A 1200V	1 IGBT per kit															
IGBT 1,2,3	176F3364	IGBT dual module 600A 1200V	1 IGBT per kit															
IGBT 1,2,3	176F3365	IGBT dual module 900A 1200V	1 IGBT per kit															
IGBT 4	176F3366	IGBT brake module 450A 1700V	1 IGBT per kit															
IGBT 4	176F3367	IGBT brake module 650A 1700V	1 IGBT per kit															
Capacitors																		
CBANK 1	176F3163	DC bus cap 4700UF 450V in housing	DC Bus Cap, 450VDC, w black cup, 1 per kit															
C1, C2, C3	176F8323	IGBT snubber cap 1000V 1.5UF	snubber cap															
C4	176F8534	IGBT snubber cap 1250V 1.0UF	snubber cap, brake IGBT															
C1, C2, C3	176F3162	IGBT snubber cap 1000V 1.5UF wide mount	snubber cap															
C4	176F3427	IGBT snubber cap 1250V 1.0UF wide mount	snubber cap, brake IGBT															
Fans																		
F2	176F3164	Heatsink Fan DC 172x51 - 48VDC	Heatsink Fan															
F1	176F3166	Top fan IP20 DC 80X25 - 48VDC	IP20 Top Fan, Fan only, 1 per kit															
F1	176F3167	Top fan IP20 DC 80X38 - 48VDC	IP20 Top Fan, Fan only, 1 per kit															
F1	176F3168	Door fan IP21/54 DC 120X25	IP21/IP54 Door Fan, Fan Only, 1 fan per kit															
F1	176F3169	Door fan IP21/54 DC 120X38	IP21/IP54 Door Fan, Fan Only, 1 fan per kit															
F3	176F3165	Mixing fan DC 40X28 - 24VDC	Mixing Fan, mounted below the input terminals															
Fuses																		
FU 1,2,3	176F3170	Fuse 315A 700V square body	Mains fuses, 1 per kit															
FU 1,2,3	176F3171	Fuse 350A 700V square body	Mains fuses, 1 per kit															
FU 1,2,3	176F3172	Fuse 400A 700V square body	Mains fuses, 1 per kit															

Block Diagram Name	Spare Part Number	Spare Part Name	Comments	200–240 V AC														
				D1h/D3h					D2h/D4h									
				FC 102 (T2)	N55K	N75K	N90K	N100	FC 202 (T2)	N55K	N75K	N90K	N100	FC 302 (T2)	N45K	N55K	N75K	N90K
FU 1,2,3	176F3173	Fuse 550A 700V square body	Mains fuses, 1 per kit															
FU 1,2,3	176F3174	Fuse 800A 700V square body	Mains fuses, 1 per kit															
FU 1,2,3	176F8335	Fuse ultra fast 630A 700V	Mains fuses, 1 per kit															
Inductors & Current Sensors																		
CT 1,2,3	176F8342	Current sensor 300A	current sensor - See P/N 244															
CT 1,2,3	176F8343	Current sensor 500A	current sensor - See P/N 244															
CT 1,2,3	176F6515	Current sensor 300A - LEM	current sensor - Used after week 3 2016															
CT 1,2,3	176F6447	Current sensor 500A - LEM	current sensor - Used after week 3 2016															
L1	176F3543	DC Link Coil small Dh frame 181uH	DC inductor															
L1	176F3544	DC Link Coil small Dh frame 140uH	DC inductor															
L1	176F3545	DC Link Coil small Dh frame 122uH	DC inductor															
L1	176F5721	DC Link Coil large Dh frame 98uH	DC inductor															
L1	176F5723	DC Link Coil large Dh frame 78uH	DC inductor															
L1	176F5724	DC Link Coil large Dh frame 65uH	DC inductor															
Disconnects, Circuit Breakers, Contactors																		
SW1	176F3433	Disconnect 400A D1h power sizes	disconnect															
SW1	176F3434	Disconnect 600A D2h power sizes	disconnect															
SW1	176F8346	Disconnect handle rod D1 frame	disconnect handle															
SW1	176F8348	Disconnect handle rod D2 frame	disconnect handle															
SW1	176F3437	Circuit breaker 320A small D1h power	circuit breaker															
SW1	176F3438	Circuit breaker 400A large D1h power	circuit breaker															
SW1	176F3439	Circuit breaker 480A small D2h power	circuit breaker															
SW1	176F3440	Circuit breaker 600A medium D2h power	circuit breaker															
SW1	176F3441	Circuit breaker 800A large D2h power	circuit breaker															
SW2	176F3435	Contact 310A D1h power sizes	contactor															
SW2	176F3436	Contact 600A D2h power sizes	contactor															
Cables																		
CBL1	176F3181	Cable LCP to control crd D1h D3h	DB9 extension cable assembly															
CBL2	176F3183	Cable control crd to power crd D1h D3h	ribbon cable-control crd to power crd															
CBL2	176F3319	Cable control crd to power crd D2h/D4h	ribbon cable-control crd to power crd															
CBL3	176F3320	Cable power crd to door fan D1h/D3h	wire harness-power crd to H/S fan & door/top fan															
CBL3	176F3321	Cable power crd to door fan D2h/D4h	wire harness-power crd to H/S fan & door/top fan															

Block Diagram Name	Spare Part Number	Spare Part Name	Comments	200-240 V AC												
				D1h/D3h			D2h/D4h									
				FC 102 (T2)	N55K	N75K	N90K	N100	N150	N160	N55K	N75K	N90K	N100	N150	N160
CBL4	176F3322	Cable power crd to CT D1h-D3h	wire harness-power crd to current sensors & mixing fan		1	1	1									
CBL4	176F3323	Cable power crd to CT D2h/D4h	wire harness-power crd to current sensors & mixing fan													
CBL5	176F3324	Cable DC bus to power crd D1h/D3h	wire harness-power crd to DC Bus		1	1	1									
CBL5	176F3325	Cable DC bus to power crd D2h/D4h	wire harness-power crd to DC Bus		1	1	1									
CBL6	176F3326	Cable power crd to HF/RFI D1h/D3h	wire harness-power crd to RFI		1	1	1									
CBL6	176F3327	Cable power crd to HF/RFI D2h/D4h	wire harness-power crd to RFI													
CBL7	176F3328	Cable power crd to gate drive D1h/D3h	ribbon cable-power crd to gate drive bd		1	1	1									
CBL7	176F3329	Cable power crd to gate drive D2h/D4h	ribbon cable-power crd to gate drive bd													
CBL8	176F3331	Cable gate drive to Inrush D1h/D3h	ribbon cable-inrush crd to gate drive bd		1	1	1									
CBL8	176F3332	Cable gate drive to Inrush D2h/D4h	ribbon cable-inrush crd to gate drive bd													
CBL10	176F3333	Cable Inrush to SCR gate D1h/D3h	wire harness-inrush crd to SCR gates		1	1	1									
CBL10	176F3336	Cable Inrush to SCR gate D2h/D4h	wire harness-inrush crd to SCR gates													
CBL11	176F3179	Cable brake IGBT gate signal D1h D3h	wire harness-gatedrive bd to brake IGBT gate, 1 per kit		1	1	1									
CBL11	176F3180	Cable brake IGBT gate signal D2h D4h	wire harness-gatedrive bd to brake IGBT gate, 1 per kit													
CBL12	176F3177	Cable IGBT temp to gate PCA D1h D3h	wire harness-gatedrive bd to IGBT NTC, 1 per kit		1	1	1									
CBL12	176F3178	Cable IGBT temp to gate PCA D2h D4h	wire harness-gatedrive bd to IGBT NTC, 1 per kit													
CBL13	176F3175	Cable IGBT gate signal D1h D3h	wire harness-gatedrive bd to IGBT gate, 1 per kit		3	3	3									
CBL13	176F3176	Cable IGBT gate signal D2h D4h	wire harness-gatedrive bd to IGBT gate, 1 per kit													
		Busbars														
	176F3338	Busbar SCR AC input D1h/D3h	busbars		3	3	3									
	176F3339	Busbar DC+ inductor to cap bank D1h/D3h	busbars		1	1	1									
	176F3340	Busbar DC- inductor to cap bank D1h/D3h	busbars		1	1	1									
	176F3341	Busbar IGBT AC output D1h/D3h	busbars		3	3	3									
	176F3346	Busbar assembly SCR to DC coil D1h/D3h	busbars		1	1	1									
	176F3347	Busbar assembly Current sensor D1h/D3h	busbars		1	1	1									
	176F6517	Busbar assembly LEM 310A curr sensor D1h/D3h	busbars		1	1	1									
	176F3350	Busbar assembly cap bank 400V D1h/D3h	busbars		1	1	1									
	176F3356	Busbar motor terminals U,V,W D1h/D3h	busbars		1	1	1									
	176F3357	Busbar mains, no fuse, no RFI D1h/D3h	busbars		1	1	1									
	176F3358	Busbar mains, fuse, no RFI D1h/D3h	busbars		1	1	1									
	176F3359	Busbar mains, RFI, no fuse D1h/D3h	busbars		1	1	1									

Block Diagram Name	Spare Part Number	Spare Part Name	Comments	200–240 V AC											
				D1h/D3h						D2h/D4h					
				FC 102 (T2)	N55K	N75K	N90K	N100	N150	N160	FC 202 (T2)	N55K	N75K	N90K	N100
	176F3360	Busbar mains, fuse, RFI D1h/D3h	busbars												
	176F3368	Busbar motor terminals UV,W D2h/D4h	busbars												
	176F3371	Busbar mains, no fuse,no RFI D2h/D4h	busbars												
	176F3372	Busbar mains,fuse,no RFI D2h/D4h	busbars												
	176F3373	Busbar mains,RFI,no fuse D2h/D4h	busbars												
	176F3374	Busbar mains,fuse,RFI D2h/D4h	busbars												
	176F3376	Busbar SCR AC input small D2h/D4h	busbars												
	176F3377	Busbar SCR AC input large D2h/D4h	busbars - See P/N 185												
	176F3378	Busbar SCR DC output small D2h/D4h	busbars												
	176F3379	Busbar SCR DC output large D2h/D4h	busbars - See P/N 185												
	176F3380	Busbar DC+ SCR to DC coil D2h/D4h	busbars												
	176F3381	Busbar DC- SCR to DC coil D2h/D4h	busbars												
	176F3382	Busbar DC+ inductor to cap bank D2h/D4h	busbars												
	176F3383	Busbar DC- inductor to cap bank D2h/D4h	busbars												
	176F3384	Busbar IGBT AC output D2h/D4h	busbars												
	176F3385	Busbar assembly current sensor D2h/D4h	busbars												
	176F3386	Busbar assembly cap bank 400V D2h/D4h	busbars												
Other Parts															
	176F3353	Door fan filter DH frame package of 10	fan filter		21/54	21/54	21/54	21/54	21/54	21/54	21/54	21/54	21/54	21/54	21/54
	176F3342	Air baffle D2h frame	enclosure												
	176F3343	Air baffle D4h frame	enclosure												
	176F3345	Cable cable 45MM DH frame	enclosure												
	176F3351	Air baffle D3h frame	enclosure												
	176F3352	Air baffle D1h frame	enclosure												
	176F3375	Door vent kit IP21/IP54 DH frame	enclosure												
	176F3389	Front cover IP20 D4h encl	enclosure												
	176F3390	Front cover IP20 D3h encl	enclosure												
	176F3479	Power terminal cover IP20 D3h encl	enclosure												
	176F3480	Power terminal cover IP20 D4h encl	enclosure												
	176F3481	Mains shield D1h frame	enclosure												
	176F3482	Mains shield D2h frame	enclosure												
	176F8430	Cable cable for frame size D & E	enclosure												

Block Diagram Name	Spare Part Number	Spare Part Name	Comments	200-240 V AC											
				D1h/D3h						D2h/D4h					
				FC 102 (T2)	N55K	N75K	N90K	N100	N150	N160	FC 202 (T2)	N55K	N75K	N90K	N100
	130B0264	Cradle for A5,B1,B2,C1 and C2 encl	insulation												
	176F3344	Bracket gate drive support D2h/D4h	insulation												
	176F3348	Bracket Inrush support D1h/D3h	insulation												
	176F3349	Bracket gate drive support D1h/D3h	insulation												
	176F3354	Insulation mains terminals D1h/D3h	insulation												
	176F3355	Insulation motor terminals D1h/D3h	insulation												
	176F3361	Bracket Inrush support D2h/D4h	Includes 2 DC bus standoffs - 177G3920												
	176F3369	Mains terminals D2h/D4h	insulation												
	176F3370	Motor terminals D2h/D4h	insulation												
	176F3388	Cradle for LCP D1h/D3h encl	insulation												
	176F3540	Heatsink Fan Cover Dh frames	enclosure												
	176F3548	Cover DC Link Coil Large Dh frame	enclosure												
	176F3549	Cover DC Link Coil Small Dh frame	enclosure												
	176F5000	Anti Condensation Heater Dh frame	resistor												
	176F5734	Front Cover IP21/IP54 D1h encl	enclosure												
	176F5735	Front Cover IP21/IP54 D2h encl	enclosure												
	176F5736	Front Cover No LCP IP21/54 D1h encl	enclosure												
	176F5737	Front Cover No LCP IP21/54 D2h encl	enclosure												
	176F5739	Extended Option Adaptor Plate D1h frame	enclosure												
	176F5740	Extended Option Adaptor Plate D2h frame	enclosure												
	176F5741	Gland Plate D1h frame	enclosure												
	176F5742	Gland Plate D2h frame	enclosure												
	176F5748	Top Plate Assembly D4h	enclosure												
	176F5747	Enclosure Left Side D4h	enclosure												
	176F5749	Enclosure Right Side D4h	enclosure												
	176F6304	Front Cover D2 w/ Disconnect Short Cab.	enclosure												

Table 15.8 Spare Parts List, D1h-D4h Drives, 200-240 V AC (T2)

Block Diagram Name	Spare Part Number	Spare part name	Comments	380–500 V AC (T4/T5)																	
				D1h/D3h/D5h/D6h				D2h/D4h/D7h/D8h													
				FC 102 (T4)	N110	N132	N160	FC 103 (T4)	N110	N132	N160	FC 202 (T4)	N110	N132	N160	FC 302 (T5)	N90k	N110	N132	N160	N200
				Control Cards																	
PCA1	130B1151	Control Card, FC102	Coated, no safe stop																		
PCA1	134B1730	Control Card, FC102	Coated, no safe stop, Ver 2 card																		
PCA1	130B1150	Control Card, FC102	Coated, safe stop																		
PCA1	134B1729	Control Card, FC102	Coated, safe stop, Ver 2 card																		
PCA1	130B6968	Control Card, FC103	Coated, no safe stop																		
PCA1	134B1724	Control Card, FC103	Coated, no safe stop, Ver 2 card																		
PCA1	130B6967	Control Card, FC103	Coated, safe stop																		
PCA1	134B1714	Control Card, FC103	Coated, safe stop, Ver 2 card																		
PCA1	130B1168	Control Card, FC202	Coated, no safe stop																		
PCA1	134B1732	Control Card, FC202	Coated, no safe stop, Ver 2 card																		
PCA1	130B1167	Control Card, FC202	Coated, safe stop																		
PCA1	134B1731	Control Card, FC202	Coated, safe stop, Ver 2 card																		
PCA1	130B1109	Control Card, FC302	Coated, safe stop																		
PCA1	134B1726	Control Card, FC302	Coated, safe stop, Ver 2 card																		
				Power Cards																	
PCA2	176F3134	Power card NO 110kW 380–480V	Conformal coated, does not include scaling card																		
PCA2	176F3135	Power card NO 132kW 380–480V	Conformal coated, does not include scaling card																		
PCA2	176F3136	Power card NO 160kW 380–480V	Conformal coated, does not include scaling card																		
PCA2	176F3137	Power card NO 200kW 380–480V	Conformal coated, does not include scaling card																		
PCA2	176F3138	Power card NO 250kW 380–480V	Conformal coated, does not include scaling card																		
PCA2	176F3139	Power card NO 315kW 380–480V	Conformal coated, does not include scaling card																		
PCA2	176F3140	Power card NO 110kW 380–500V	Conformal coated, does not include scaling card																		
PCA2	176F3141	Power card NO 132kW 380–500V	Conformal coated, does not include scaling card																		
PCA2	176F3142	Power card NO 160kW 380–500V	Conformal coated, does not include scaling card																		
PCA2	176F3143	Power card NO 200kW 380–500V	Conformal coated, does not include scaling card																		
PCA2	176F3144	Power card NO 250kW 380–500V	Conformal coated, does not include scaling card																		
PCA2	176F3145	Power card NO 315kW 380–500V	Conformal coated, does not include scaling card																		
PCA2	176F3509	Power card rugged NO 110kW 380–480V	Conformal coated, does not include scaling card																		
PCA2	176F3510	Power card rugged NO 132kW 380–480V	Conformal coated, does not include scaling card																		
PCA2	176F3511	Power card rugged NO 160kW 380–480V	Conformal coated, does not include scaling card																		

Block Diagram Name	Spare Part Number	Spare part name	Comments	380-500 V AC (T4/T5)																						
				D1h/D3h/D5h/D6h						D2h/D4h/D7h/D8h																
				FC 102 (T4)	N110	N132	N160	N200	N250	FC 103 (T4)	N110	N132	N160	N200	N250	FC 202 (T4)	N110	N132	N160	N200	N250	FC 302 (T5)	N90k	N110	N132	N160
PCA2	176F3512	Power card rugged NO 200kW 380-480V	Conformal coated, does not include scaling card																							
PCA2	176F3513	Power card rugged NO 250kW 380-480V	Conformal coated, does not include scaling card																							
PCA2	176F3514	Power card rugged NO 315kW 380-480V	Conformal coated, does not include scaling card																							
PCA2	176F3503	Power card rugged NO 110kW 380-500V	Conformal coated, does not include scaling card																							
PCA2	176F3504	Power card rugged NO 132kW 380-500V	Conformal coated, does not include scaling card																							
PCA2	176F3505	Power card rugged NO 160kW 380-500V	Conformal coated, does not include scaling card																							
PCA2	176F3506	Power card rugged NO 200kW 380-500V	Conformal coated, does not include scaling card																							
PCA2	176F3507	Power card rugged NO 250kW 380-500V	Conformal coated, does not include scaling card																							
PCA2	176F3508	Power card rugged NO 315kW 380-500V	Conformal coated, does not include scaling card																							
Other Printed Circuit Cards																										
PCA3	176F3153	Current scaling card 4.57 ohm 400V	Installs on the power card																							
PCA3	176F3154	Current scaling card 3.82 ohm 400V	Installs on the power card																							
PCA3	176F3155	Current scaling card 3.11 ohm 400V	Installs on the power card																							
PCA3	176F3156	Current scaling card 2.56 ohm 400V	Installs on the power card																							
PCA3	176F3157	Current scaling card 5.10 ohm 400V	Installs on the power card																							
PCA3	176F3158	Current scaling card 4.22 ohm 400V	Installs on the power card																							
PCA4	176F3159	Inrush card NO 110-315kW 400V	Soft-charge/inrush card																							
PCA4	176F3517	Inrush card rugged NO 110-315kW 400V	Soft-charge/inrush card																							
PCA5	176F3160	Gatedrive card NO 110-315kW 400V	Gatedrive card																							
PCA5	176F3515	Gatedrive card rugged NO 110-315kW 400V	Gatedrive card																							
PCA5	176F6300	Gatedrive card special version	Gatedrive card - S056 variant																							
PCA6	176F3387	RFI card NO 110-315kW 400V	RFI class A1 board																							
PCA7	176F3161	Balance/HF card NO 110-315kW 400V	DC bus cap balance/high frequency card																							
Semiconductors																										
SCR 1,2,3	176F3337	Rectifier SCR/diode 503A 1600V	SCR/diode, 1 per kit - see product note 185																							
SCR 1,2,3	176F8318	Rectifier SCR/diode 175A 1600V	SCR/diode, 1 per kit																							
SCR 1,2,3	176F8320	Rectifier SCR/diode 330A 1600V	SCR/diode, 1 per kit, includes standoff to inrush card																							
IGBT 1,2,3	176F3362	IGBT dual module 300A 1200V	IGBT module, 1 per kit																							
IGBT 1,2,3	176F3363	IGBT dual module 450A 1200V	IGBT module, 1 per kit																							
IGBT 1,2,3	176F3364	IGBT dual module 600A 1200V	IGBT module, 1 per kit																							
IGBT 1,2,3	176F3365	IGBT dual module 900A 1200V	IGBT module, 1 per kit																							

Block Diagram Name	Spare Part Number	Spare part name	Comments	380–500 V AC (T4/T5)																							
				D1h/D3h/D5h/D6h						D2h/D4h/D7h/D8h																	
				FC 102 (T4)	N110	N132	N160	N200	N250	FC 103 (T4)	N110	N132	N160	N200	N250	FC 202 (T4)	N110	N132	N160	N200	N250	FC 302 (T5)	N90k	N110	N132	N160	N200
IGBT 4	176F3366	IGBT brake module 450A 1700V	IGBT module, 1 per kit																								
IGBT 4	176F3367	IGBT brake module 650A 1700V	IGBT module, 1 per kit																								
Capacitors																											
CBank 1	176F3163	DC bus cap 4700UF 450V single in housing	DC bus capacitor, 450VDC, includes black cup, 1 per kit																								
C1, C2, C3	176F8323	IGBT snubber cap 1000V 1.5UF	Snubber capacitor																								
C4	176F8534	IGBT snubber cap 1250V 1.0UF	Snubber capacitor, brake IGBT																								
C1, C2, C3	176F3162	IGBT snubber cap 1000V 1.5UF wide mount	Snubber capacitor																								
C4	176F3427	IGBT snubber cap 1250V 1.0UF wide mount	Snubber capacitor, brake IGBT																								
Fans																											
F2	176F3164	Heat sink fan DC 172x51 48VDC	Heat sink fan																								
F1	176F3166	Top fan IP20 DC 80X25 48VDC	IP20 top fan, fan only																								
F1	176F3167	Top fan IP20 DC 80X38 48VDC	IP20 top fan, fan only																								
F1	176F3168	Door fan IP21/54 DC 120X25	IP21/IP54 door fan, fan only, 1 fan																								
F1	176F3169	Door fan IP21/54 DC 120X38	IP21/IP54 door fan, fan only, 1 fan																								
F3	176F3165	Mixing fan DC 40X28 - 24VDC	Mixing fan, mounted below the input terminals																								
Fuses																											
FU 1,2,3	176F3170	Fuse 315A 700V square body	Mains fuses, 1 per kit																								
FU 1,2,3	176F3171	Fuse 350A 700V square body	Mains fuses, 1 per kit																								
FU 1,2,3	176F3172	Fuse 400A 700V square body	Mains fuses, 1 per kit																								
FU 1,2,3	176F3173	Fuse 550A 700V square body	Mains fuses, 1 per kit																								
FU 1,2,3	176F3174	Fuse 800A 700V square body	Mains fuses, 1 per kit																								
FU 1,2,3	176F8335	Fuse ultra fast 630A 700V	Mains fuses, 1 per kit																								
Inductors and Current Sensors																											
CT 1,2,3	176F8342	Current sensor 300A	Current sensor - see product note 244																								
CT 1,2,3	176F8343	Current sensor 500A	Current sensor - see product note 244																								
CT 1,2,3	176F6515	Current sensor 300A - LEM	Current sensor - used after week 3 2016																								
CT 1,2,3	176F6447	Current sensor 500A - LEM	Current sensor - used after week 3 2016																								
L1	176F3543	DC link coil small Dxh 181uH	DC inductor																								
L1	176F3544	DC link coil small Dxh 140uH	DC inductor																								
L1	176F3545	DC link coil small Dxh 122uH	DC inductor																								
L1	176F5721	DC link coil large Dxh 98uH	DC inductor																								

Block Diagram Name	Spare Part Number	Spare part name	Comments	380-500 V AC (T4/T5)																
				D1h/D3h/D5h/D6h						D2h/D4h/D7h/D8h										
				FC 102 (T4)	N110	N132	N160	N200	N315	FC 103 (T4)	N110	N132	N160	N200	N315					
L1	176F5723	DC link coil large Dxh 78uH	DC inductor																	
L1	176F5724	DC link coil large Dxh 65uH	DC inductor																	
Disconnects																				
SW1	176F3433	Disconnect 400A D1h power sizes	Disconnect				1	1	1											
SW1	176F3434	Disconnect 600A D2h power sizes	Disconnect																	
SW1	176F8348	Disconnect handle rod D2 enclosure	Disconnect handle				1	1	1	1	1	1	1	1	1	1	1	1	1	1
Circuit Breakers and Contactors																				
SW1	176F3437	Circuit breaker 320A small D1h power	Circuit breaker				1	1												
SW1	176F3438	Circuit breaker 400A large D1h power	Circuit breaker																	
SW1	176F3439	Circuit breaker 480A small D2h power	Circuit breaker																	
SW1	176F3440	Circuit breaker 600A medium D2h power	Circuit breaker																	
SW1	176F3441	Circuit breaker 800A large D2h power	Circuit breaker																	
SW2	176F3435	Contact 310A D1h power sizes	Contact																	
SW2	176F3436	Contact 600A D2h power sizes	Contact																	
Cables																				
CBL1	176F3181	Cable LCP to control card D1h D3h	DB9 extension cable assembly																	
CBL2	176F3183	Cable control card to power card D1h D3h	Ribbon cable, control card to power card																	
CBL2	176F3319	Cable control card to power card D2h/D4h	Ribbon cable, control card to power card																	
CBL3	176F3320	Cable power card to door fan D1h/D3h	Wire harness, power card to H/S fan & door/top fan																	
CBL3	176F3321	Cable power card to door fan D2h/D4h	Wire harness, power card to H/S fan & door/top fan																	
CBL4	176F3322	Cable power card to CT D1h/D3h	Wire harness, power card to current sensors/mix fan																	
CBL4	176F3323	Cable power card to CT D2h/D4h	Wire harness, power card to current sensors/mix fan																	
CBL5	176F3324	Cable DC bus to power card D1h/D3h	Wire harness, power card to DC bus																	
CBL5	176F3325	Cable DC bus to power card D2h/D4h	Wire harness, power card to DC bus																	
CBL6	176F3326	Cable power card to HF/RFI D1h/D3h	Wire harness, power card to RFI																	
CBL6	176F3327	Cable power card to HF/RFI D2h/D4h	Wire harness, power card to RFI																	
CBL7	176F3328	Cable power card to gatedrive D1h/D3h	Ribbon cable, power card to gatedrive card																	
CBL7	176F3329	Cable power card to gatedrive D2h/D4h	Ribbon cable, power card to gatedrive card																	
CBL8	176F3331	Cable gatedrive to inrush D1h/D3h	Ribbon cable, inrush card to gatedrive card																	
CBL8	176F3332	Cable gatedrive to inrush D2h/D4h	Ribbon cable, inrush card to gatedrive card																	
CBL10	176F3333	Cable inrush to SCR gate D1h/D3h	Wire harness, inrush card to SCR gates																	

Block Diagram Name	Spare Part Number	Spare part name	Comments	380–500 V AC (T4/T5)																							
				D1h/D3h/D5h/D6h						D2h/D4h/D7h/D8h																	
				FC 102 (T4)	N110	N132	N160	N200	N250	FC 103 (T4)	N110	N132	N160	N200	N250	FC 202 (T4)	N110	N132	N160	N200	N250	FC 302 (T5)	N90k	N110	N132	N160	N200
CBL10	176F3336	Cable inrush to SCR gate D2h/D4h	Wire harness, inrush card to SCR gates																								
CBL11	176F3179	Cable brake IGBT gate signal D1h D3h	Wire harness, gatedrive card to brake IGBT, 1 per kit																								
CBL11	176F3180	Cable brake IGBT gate signal D2h D4h	Wire harness, gatedrive card to brake IGBT, 1 per kit																								
CBL12	176F3177	Cable IGBT temp to gate PCA D1h D3h	Wire harness, gatedrive card to IGBT NTC, 1 per kit																								
CBL12	176F3178	Cable IGBT temp to gate PCA D2h D4h	Wire harness, gatedrive card to IGBT NTC, 1 per kit																								
CBL13	176F3175	Cable IGBT gate signal D1h D3h	Wire harness, gatedrive card to IGBT gates, 1 per kit																								
CBL13	176F3176	Cable IGBT gate signal D2h D4h	Wire harness, gatedrive card to IGBT gates, 1 per kit																								
		Busbars																									
	176F3338	Busbar SCR AC input D1h/D3h	Busbars																								
	176F3339	Busbar DC+ inductor to cap bank D1h/D3h	Busbars																								
	176F3340	Busbar DC- inductor to cap bank D1h/D3h	Busbars																								
	176F3341	Busbar IGBT AC output D1h/D3h	Busbars																								
	176F3346	Busbar assy SCR to DC coil D1h/D3h	Busbars																								
	176F3347	Busbar assy curr sens D1h/D3h	Busbars																								
	176F6517	Busbar assy LEM 310A curr sens D1h/D3h	Busbars																								
	176F3350	Busbar assy cap bank 400V D1h/D3h	Busbars																								
	176F3356	Busbar motor terminals U,V,W D1h/D3h	Busbars																								
	176F3357	Busbar mains, no fuse, no RFI D1h/D3h	Busbars																								
	176F3358	Busbar mains, fuse, no RFI D1h/D3h	Busbars																								
	176F3359	Busbar mains, RFI, no fuse D1h/D3h	Busbars																								
	176F3360	Busbar mains, fuse, RFI D1h/D3h	Busbars																								
	176F3368	Busbar motor terminals U,V,W D2h/D4h	Busbars																								
	176F3371	Busbar mains, no fuse, no RFI D2h/D4h	Busbars																								
	176F3372	Busbar mains, fuse, no RFI D2h/D4h	Busbars																								
	176F3373	Busbar mains, RFI, no fuse D2h/D4h	Busbars																								
	176F3374	Busbar mains, fuse, RFI D2h/D4h	Busbars																								
	176F3376	Busbar SCR AC input small D2h/D4h	Busbars																								
	176F3377	Busbar SCR AC input large D2h/D4h	Busbars - see product note 185																								
	176F3378	Busbar SCR DC output small D2h/D4h	Busbars																								
	176F3379	Busbar SCR DC output large D2h/D4h	Busbars - see product note 185																								
	176F3380	Busbar DC+ SCR to DC coil D2h/D4h	Busbars																								

Block Diagram Name	Spare Part Number	Spare part name	Comments	380-500 V AC (T4/T5)																				
				D1h/D3h/D5h/D6h								D2h/D4h/D7h/D8h												
				FC 102 (T4)	N110	N132	N160	N200	N250	N315	N110	N132	N160	N200	N250	N315								
	176F3381	Busbar DC- SCR to DC coil D2h/D4h	Busbars	-	-	-	-	-	-	-	-	-	-	-	-	-	-	-	-	-	-	-	-	-
	176F3382	Busbar DC+ inductor to cap bank D2h/D4h	Busbars	-	-	-	-	-	-	-	-	-	-	-	-	-	-	-	-	-	-	-	-	-
	176F3383	Busbar DC- inductor to cap bank D2h/D4h	Busbars	-	-	-	-	-	-	-	-	-	-	-	-	-	-	-	-	-	-	-	-	-
	176F3384	Busbar IGBT AC output D2h/D4h	Busbars	-	-	-	-	-	-	-	-	-	-	-	-	-	-	-	-	-	-	-	-	-
	176F3385	Busbar assy current sensor D2h/D4h	Busbars	-	-	-	-	-	-	-	-	-	-	-	-	-	-	-	-	-	-	-	-	-
	176F3386	Busbar assy cap bank 400V D2h/D4h	Busbars	-	-	-	-	-	-	-	-	-	-	-	-	-	-	-	-	-	-	-	-	-
		Other Parts																						
	176F3353	Door fan filter Dxh enclosure, package of 10	Fan filter	21/54	21/54	21/54	21/54	21/54	21/54	21/54	21/54	21/54	21/54	21/54	21/54	21/54	21/54	21/54	21/54	21/54	21/54	21/54	21/54	21/54
	176F3342	Air baffle D2h enclosure	Enclosure	-	-	-	-	-	-	-	-	-	-	-	-	-	-	-	-	-	-	-	-	-
	176F3343	Air baffle D4h enclosure	Enclosure	-	-	-	-	-	-	-	-	-	-	-	-	-	-	-	-	-	-	-	-	-
	176F3345	Cable clamp 45mm Dxh enclosure	Enclosure	4	4	4	4	4	4	4	4	4	4	4	4	4	4	4	4	4	4	4	4	4
	176F3351	Air baffle D3h enclosure	Enclosure	IP20	IP20	IP20	IP20	IP20	IP20	IP20	IP20	IP20	IP20	IP20	IP20	IP20	IP20	IP20	IP20	IP20	IP20	IP20	IP20	IP20
	176F3352	Air baffle D1h enclosure	Enclosure	21/54	21/54	21/54	21/54	21/54	21/54	21/54	21/54	21/54	21/54	21/54	21/54	21/54	21/54	21/54	21/54	21/54	21/54	21/54	21/54	21/54
	176F3375	Door vent kit IP21/IP54 Dxh enclosure	Enclosure	21/54	21/54	21/54	21/54	21/54	21/54	21/54	21/54	21/54	21/54	21/54	21/54	21/54	21/54	21/54	21/54	21/54	21/54	21/54	21/54	21/54
	176F3389	Front cover IP20 D4h enclosure	Enclosure	-	-	-	-	-	-	-	-	-	-	-	-	-	-	-	-	-	-	-	-	-
	176F3390	Front cover IP20 D3h enclosure	Enclosure	IP20	IP20	IP20	IP20	IP20	IP20	IP20	IP20	IP20	IP20	IP20	IP20	IP20	IP20	IP20	IP20	IP20	IP20	IP20	IP20	IP20
	176F3479	Power terminal cover IP20 D3h enclosure	Enclosure	IP20	IP20	IP20	IP20	IP20	IP20	IP20	IP20	IP20	IP20	IP20	IP20	IP20	IP20	IP20	IP20	IP20	IP20	IP20	IP20	IP20
	176F3480	Power terminal cover IP20 D4h enclosure	Enclosure	-	-	-	-	-	-	-	-	-	-	-	-	-	-	-	-	-	-	-	-	-
	176F3481	Mains shield D1h enclosure	Enclosure	21/54	21/54	21/54	21/54	21/54	21/54	21/54	21/54	21/54	21/54	21/54	21/54	21/54	21/54	21/54	21/54	21/54	21/54	21/54	21/54	21/54
	176F3482	Mains shield D2h enclosure	Enclosure	-	-	-	-	-	-	-	-	-	-	-	-	-	-	-	-	-	-	-	-	-
	176F8430	Cable clamp for enclosure size D & E	Enclosure	-	-	-	-	-	-	-	-	-	-	-	-	-	-	-	-	-	-	-	-	-
	130B0264	Cradle for A5,B1,B2,C1 and C2 enclosure	Insulation	-	-	-	-	-	-	-	-	-	-	-	-	-	-	-	-	-	-	-	-	-
	176F3344	Bracket gatedrive support D2h/D4h	Insulation	-	-	-	-	-	-	-	-	-	-	-	-	-	-	-	-	-	-	-	-	-
	176F3348	Bracket inrush support D1h/D3h	Insulation	1	1	1	1	1	1	1	1	1	1	1	1	1	1	1	1	1	1	1	1	1
	176F3349	Bracket gatedrive support D1h/D3h	Insulation	1	1	1	1	1	1	1	1	1	1	1	1	1	1	1	1	1	1	1	1	1
	176F3354	Insulation mains terminals D1h/D3h	Insulation	1	1	1	1	1	1	1	1	1	1	1	1	1	1	1	1	1	1	1	1	1
	176F3355	Insulation motor terminals D1h/D3h	Insulation	1	1	1	1	1	1	1	1	1	1	1	1	1	1	1	1	1	1	1	1	1
	176F3361	Bracket inrush support D2h/D4h	DC bus standoffs, includes 2	-	-	-	-	-	-	-	-	-	-	-	-	-	-	-	-	-	-	-	-	-
	176F3369	Mains terminals D2h/D4h	Insulation	-	-	-	-	-	-	-	-	-	-	-	-	-	-	-	-	-	-	-	-	-
	176F3370	Motor terminals D2h/D4h	Insulation	-	-	-	-	-	-	-	-	-	-	-	-	-	-	-	-	-	-	-	-	-
	176F3388	Cradle for LCP D1h/D3h enclosure	Insulation	1	1	1	1	1	1	1	1	1	1	1	1	1	1	1	1	1	1	1	1	1

Block Diagram Name	Spare Part Number	Spare part name	Comments	380–500 V AC (T4/T5)														
				D1h/D3h/D5h/D6h						D2h/D4h/D7h/D8h								
				FC 102 (T4)	N110	N132	N160	FC 103 (T4)	N110	N132	N160	FC 202 (T4)	N110	N132	N160	FC 302 (T5)	N90k	N110
	176F3540	Heat sink fan cover D4h enclosures	Enclosure		1	1	1	1	1	1	1	1	1	1	1	1	1	1
	176F3548	Cover DC link coil large D4h enclosure	Enclosure		-	-	-	-	-	-	-	-	-	-	-	-	-	-
	176F3549	Cover DC link coil small D4h enclosure	Enclosure		1	1	1	1	1	1	1	1	1	1	1	1	1	1
	176F5000	Anti-condensation heater D4h enclosure	Resistor		1	1	1	1	1	1	1	1	1	1	1	1	1	1
	176F5734	Front cover IP21/IP54 D1h enclosure	Enclosure		21/54	21/54	21/54	21/54	21/54	21/54	21/54	21/54	21/54	21/54	21/54	21/54	21/54	21/54
	176F5735	Front cover IP21/IP54 D2h enclosure	Enclosure		-	-	-	-	-	-	-	-	-	-	-	-	-	-
	176F5736	Front cover no LCP IP21/54 D1h enclosure	Enclosure		21/54	21/54	21/54	21/54	21/54	21/54	21/54	21/54	21/54	21/54	21/54	21/54	21/54	21/54
	176F5737	Front cover no LCP IP21/54 D2h enclosure	Enclosure		-	-	-	-	-	-	-	-	-	-	-	-	-	-
	176F5739	Extended option adapter plate D1h enclosure	Enclosure		1	1	1	1	1	1	1	1	1	1	1	1	1	1
	176F5740	Extended option adapter plate D2h enclosure	Enclosure		-	-	-	-	-	-	-	-	-	-	-	-	-	-
	176F5741	Gland plate D1h enclosure	Enclosure		21/54	21/54	21/54	21/54	21/54	21/54	21/54	21/54	21/54	21/54	21/54	21/54	21/54	21/54
	176F5742	Gland plate D2h enclosure	Enclosure		-	-	-	-	-	-	-	-	-	-	-	-	-	-
	176F5748	Top plate assembly D4h	Enclosure		-	-	-	-	-	-	-	-	-	-	-	-	-	-
	176F5747	Enclosure left side D4h	Enclosure		-	-	-	-	-	-	-	-	-	-	-	-	-	-
	176F5749	Enclosure right side D4h	Enclosure		-	-	-	-	-	-	-	-	-	-	-	-	-	-
	176F6304	Front cover D2 w/ disconnect short cab.	Enclosure		-	-	-	-	-	-	-	-	-	-	-	-	-	-

Table 15.9 Spare Parts List, D1h–D8h Drives, 380–500 V AC (T4/T5)

Block Diagram Name	Spare Part Number	Spare part name	Comments	525-690 V AC (T7)														
				D1h/D3h/D5h/D6h							D2h/D4h/D7h/D8h							
				FC 102	N75k	N90k	N110	N132	N160	N200	FC 202	N75k	N90k	N110	N132	N160	N200	N250
Control Cards																		
PCA1	130B1151	Control Card, FC102	coated, no safe stop															
PCA1	134B1730	Control Card, FC102	coated, no safe stop, Ver 2 card															
PCA1	130B1150	Control Card, FC102	coated, safe stop															
PCA1	134B1729	Control Card, FC102	coated, safe stop, Ver 2 card															
PCA1	130B6968	Control Card, FC103	coated, no safe stop															
PCA1	134B1724	Control Card, FC103	coated, no safe stop, Ver 2 card															
PCA1	130B6967	Control Card, FC103	coated, safe stop															
PCA1	134B1714	Control Card, FC103	coated, safe stop, Ver 2 card															
PCA1	130B1168	Control Card, FC202	coated, no safe stop															
PCA1	134B1732	Control Card, FC202	coated, no safe stop, Ver 2 card															
PCA1	130B1167	Control Card, FC202	coated, safe stop															
PCA1	134B1731	Control Card, FC202	coated, safe stop, Ver 2 card															
PCA1	130B1109	Control Card, FC302	coated, safe stop															
PCA1	134B1726	Control Card, FC302	coated, safe stop, Ver 2 card															
Power Cards																		
PCA2	176F3420	Power card NO 75kW 525-690V	Conformal coated, without scaling card															
PCA2	176F3421	Power card NO 90kW 525-690V	Conformal coated, without scaling card															
PCA2	176F3152	Power card NO 110kW 525-690V	Conformal coated, without scaling card															
PCA2	176F3146	Power card NO 132kW 525-690V	Conformal coated, without scaling card															
PCA2	176F3147	Power card NO 160kW 525-690V	Conformal coated, without scaling card															
PCA2	176F3148	Power card NO 200kW 525-690V	Conformal coated, without scaling card															
PCA2	176F3149	Power card NO 250kW 525-690V	Conformal coated, without scaling card															
PCA2	176F3150	Power card NO 315kW 525-690V	Conformal coated, without scaling card															
PCA2	176F3151	Power card NO 400kW 525-690V	Conformal coated, without scaling card															
PCA2	176F3494	Power card rugged NO 75kW 525-690V	Conformal coated, without scaling card															
PCA2	176F3495	Power card rugged NO 90kW 525-690V	Conformal coated, without scaling card															
PCA2	176F3496	Power card rugged NO 110kW 525-690V	Conformal coated, without scaling card															
PCA2	176F3497	Power card rugged NO 132kW 525-690V	Conformal coated, without scaling card															
PCA2	176F3498	Power card rugged NO 160kW 525-690V	Conformal coated, without scaling card															

15

Block Diagram Name	Spare Part Number	Spare part name	Comments	525–690 V AC (T7)														
				D1h/D3h/D5h/D6h						D2h/D4h/D7h/D8h								
				FC 102	N75k	N90k	N110	N132	N160	N200	N250	N315	N400					
PCA2	176F3499	Power card rugged NO 200kW 525–690V	Conformal coated, without scaling card															
PCA2	176F3500	Power card rugged NO 250kW 525–690V	Conformal coated, without scaling card											T7				
PCA2	176F3501	Power card rugged NO 315kW 525–690V	Conformal coated, without scaling card														T7	
PCA2	176F3502	Power card rugged NO 400kW 525–690V	Conformal coated, without scaling card															T7
Other Printed Circuit Cards																		
PCA3	176F3411	Current scaling card 5.91 ohm 690V	Installs on the power card	1	1	1	1	1	1	1	1	1	1	1	1	1	1	1
PCA3	176F3412	Current scaling card 5.00 ohm 690V	Installs on the power card							1								
PCA3	176F3413	Current scaling card 4.02 ohm 690V	Installs on the power card									1						
PCA3	176F3414	Current scaling card 3.20 ohm 690V	Installs on the power card										1					
PCA3	176F3415	Current scaling card 2.67 ohm 690V	Installs on the power card														1	
PCA3	176F3416	Current scaling card 5.62 ohm 690V	Installs on the power card															1
PCA4	176F3417	Inrush card NO 75–400kW 690V	Soft-charge/inrush card	1	1	1	1	1	1	1	1	1	1	1	1	1	1	1
PCA4	176F3518	Inrush card rugged NO 75–400kW 690V	Soft-charge/inrush card	1	1	1	1	1	1	1	1	1	1	1	1	1	1	1
PCA5	176F3418	Gatedrive card NO 75–400kW 690V	Gatedrive card	1	1	1	1	1	1	1	1	1	1	1	1	1	1	1
PCA5	176F3516	Gatedrive card rugged NO 75–400kW 690V	Gatedrive card	1	1	1	1	1	1	1	1	1	1	1	1	1	1	1
PCA7	176F3419	Balance/HF card NO 75–400kW 690V	DC bus cap balance/HF card	1	1	1	1	1	1	1	1	1	1	1	1	1	1	1
Semiconductors																		
SCR1,2,3	176F3426	Rectifier SCR/diode 429A 2200V	SCR/diode, 1 per kit														3	3
SCR1,2,3	176F8529	Rectifier SCR/diode 160A 2200V	SCR/diode, 1 per kit	3	3	3	3	3	3	3	3	3	3	3	3	3	3	3
SCR1,2,3	176F8530	Rectifier SCR/diode 280A 2200V	SCR/diode, 1 per kit													3	3	3
IGBT1,2,3	176F3422	IGBT dual module 300A 1700V	IGBT module, 1 per kit	3	3	3	3	3	3	3	3	3	3	3	3	3	3	3
IGBT1,2,3	176F3423	IGBT dual module 450A 1700V	IGBT module, 1 per kit							3								
IGBT1,2,3	176F3424	IGBT dual module 450A 1700V	IGBT module, 1 per kit												3			
IGBT1,2,3	176F3425	IGBT dual module 650A 1700V	IGBT module, 1 per kit														3	3
IGBT4	176F3366	IGBT brake module 450A 1700V	IGBT module, 1 per kit	brake	brake	brake	brake	brake	brake	brake	brake	brake	brake	brake	brake	brake	brake	brake
IGBT4	176F3367	IGBT brake module 650A 1700V	IGBT module, 1 per kit															
Capacitors																		
CBANK1	176F3428	DC bus cap T7 drive single in housing	DC bus cap, 385VDC, with black cup, 1 per kit	6	6	6	6	6	6	6	6	6	6	6	6	6	6	6
C1,C2,C3	176F8534	IGBT snubber cap 1250V 1.0 UF	Snubber cap, IGBT	3	3	3	3	3	3	3	3	3	3	3	3	3	3	3
C4	176F8534	IGBT snubber cap 1250V 1.0UF	Snubber cap, brake IGBT	1	1	1	1	1	1	1	1	1	1	1	1	1	1	1
C1,C2,C3	176F3427	IGBT snubber cap 1250V 1.0 UF wide mount	Snubber cap, IGBT													3	3	3

Block Diagram Name	Spare Part Number	Spare part name	Comments	525-690 V AC (T7)																							
				D1h/D3h/D5h/D6h						D2h/D4h/D7h/D8h																	
				FC 102	N75k	N90k	N110	N132	N160	N200	N250	N315	N400	FC 103	N75k	N90k	N110	N132	N160	N200	N250	N315	N400				
C4	176F3427	IGBT snubber cap 1250V 1.0 UF wide mount	Snubber cap, brake IGBT																								
Fans																											
F2	176F3164	Heat sink fan DC 172x51 48VDC	Heat sink fan				1	1	1	1	1	1															
F1	176F3166	Top fan IP20 DC 80X25 48VDC	IP20 top fan, fan only, 1 per kit				IP20	IP20	IP20	IP20	IP20																
F1	176F3167	Top fan IP20 DC 80X38 48VDC	IP20 top fan, fan only, 1 per kit														IP20	IP20									
F1	176F3168	Door fan IP21/54 DC 120X25 48VDC	IP21/IP54 door fan, fan only, 1 per kit				21/54	21/54	21/54	21/54	21/54																
F1	176F3169	Door fan IP21/54 DC 120X38 48VDC	IP21/IP54 door fan, fan only, 1 per kit																								
F3	176F3165	Mixing fan DC 40X28 24VDC	Mixing fan, mounted below input terminals				1	1	1	1	1																
Fuses																											
FU1,2,3	176F3429	Fuse 160A 700V square body	Mains fuse, 1 per kit				3																				
FU1,2,3	176F3170	Fuse 315A 700V square body	Mains fuse, 1 per kit					3	3	3																	
FU1,2,3	176F3173	Fuse 550A 700V square body	Mains fuse, 1 per kit														3	3	3								
Inductors and Current Sensors																											
CT1,2,3	176F8342	Current sensor 300A	Current sensor, 1 per kit				3	3	3	3	3	3	3	3	3	3	3	3	3	3	3	3	3				
CT1,2,3	176F8343	Current sensor 500A	Current sensor - see product note 244																								
L1	176F3543	DC link coil small Dxh 181uH	DC link inductor				1	1	1	1	1	1															
L1	176F5722	DC link coil large Dxh 140uH	DC link inductor																		1	1	1				
L1	176F5721	DC link coil large Dxh 98uH	DC link inductor																							1	
L1	176F5723	DC link coil large Dxh 78uH	DC link inductor																								1
Disconnects, Circuit Breakers, Contactors																											
SW1	176F3433	Disconnect 400A D1h power sizes	Disconnect				1	1	1	1	1	1															
SW1	176F3434	Disconnect 600A D2h power sizes	Disconnect																	1	1	1	1	1	1	1	1
SW1	176F8348	Disconnect handle rod D2 enclosure	Disconnect handle				1	1	1	1	1	1	1	1	1	1	1	1	1	1	1	1	1	1	1	1	1
SW1	176F3437	Circuit breaker 320A small D1h power	Circuit breaker				1	1	1	1	1	1															
SW1	176F3439	Circuit breaker 480A small D2h power	Circuit breaker																	1	1	1	1	1	1	1	1
SW1	176F3440	Circuit breaker 600A medium D2h power	Circuit breaker																								
SW2	176F3435	Contact 310A D1h power sizes	Contact				1	1	1	1	1	1															
SW2	176F3436	Contact 600A D2h power sizes	Contact																								
Cables																											
CBL1	176F3181	Cable LCP to control card D1h D3h	DB9 extension cable assembly				1	1	1	1	1	1															
CBL2	176F3183	Cable control card to power card D1h D3h	Ribbon cable, control card to power card				1	1	1	1	1	1															

Block Diagram Name	Spare Part Number	Spare part name	Comments	525–690 V AC (T7)																			
				D1h/D3h/D5h/D6h							D2h/D4h/D7h/D8h												
				FC 102	N75k	N90k	N110	N132	N160	N200	N250	N315	N400	N75k	N90k	N110	N132	N160	N200	N250	N315	N400	
CBL2	176F3319	Cable control card to power card D2h/D4h	Ribbon cable, control card to power card	-	-	-	-	-	-	-	-	-	-	-	-	-	-	-	-	-	-	-	-
CBL3	176F3320	Cable power card to door fan D1h/D3h	Wire harness, PCA to H/S fan & door/top fan	1	1	1	1	1	1	1	1	1	1	1	1	1	1	1	1	1	1	1	1
CBL3	176F3321	Cable power card to door fan D2h/D4h	Wire harness, PCA to H/S fan & door/top fan	-	-	-	-	-	-	-	-	-	-	-	-	-	-	-	-	-	-	-	-
CBL4	176F3322	Cable power card to CT D1h-D3h	Wire harness, power card to CT/mixing fan	1	1	1	1	1	1	1	1	1	1	1	1	1	1	1	1	1	1	1	1
CBL4	176F3323	Cable power card to CT D2h/D4h	Wire harness, power card to CT/mixing fan	-	-	-	-	-	-	-	-	-	-	-	-	-	-	-	-	-	-	-	-
CBL5	176F3324	Cable DC bus to power card D1h/D3h	Wire harness, power card to DC bus	1	1	1	1	1	1	1	1	1	1	1	1	1	1	1	1	1	1	1	1
CBL5	176F3325	Cable DC bus to power card D2h/D4h	Wire harness, power card to DC bus	-	-	-	-	-	-	-	-	-	-	-	-	-	-	-	-	-	-	-	-
CBL6	176F3326	Cable power card to HF/RFI D1h/D3h	Wire harness, power card to RFI	1	1	1	1	1	1	1	1	1	1	1	1	1	1	1	1	1	1	1	1
CBL6	176F3327	Cable power card to HF/RFI D2h/D4h	Wire harness, power card to RFI	-	-	-	-	-	-	-	-	-	-	-	-	-	-	-	-	-	-	-	-
CBL7	176F3328	Cable power card to gatedrive D1h/D3h	Ribbon cable, power card to gatedrive card	1	1	1	1	1	1	1	1	1	1	1	1	1	1	1	1	1	1	1	1
CBL7	176F3329	Cable power card to gatedrive D2h/D4h	Ribbon cable, power card to gatedrive card	-	-	-	-	-	-	-	-	-	-	-	-	-	-	-	-	-	-	-	-
CBL8	176F3331	Cable gatedrive to inrush D1h/D3h	Ribbon cable, inrush card to gatedrive card	1	1	1	1	1	1	1	1	1	1	1	1	1	1	1	1	1	1	1	1
CBL8	176F3332	Cable gatedrive to inrush D2h/D4h	Ribbon cable, inrush card to gatedrive card	-	-	-	-	-	-	-	-	-	-	-	-	-	-	-	-	-	-	-	-
CBL10	176F3333	Cable inrush to SCR gate D1h/D3h	Wire harness, inrush card to SCR gates	1	1	1	1	1	1	1	1	1	1	1	1	1	1	1	1	1	1	1	1
CBL10	176F3336	Cable inrush to SCR gate D2h/D4h	Wire harness, inrush card to SCR gates	-	-	-	-	-	-	-	-	-	-	-	-	-	-	-	-	-	-	-	-
CBL11	176F3179	Cable brake IGBT gate signal D1h D3h	Wire harness, gatedrive card to brake IGBT	1	1	1	1	1	1	1	1	1	1	1	1	1	1	1	1	1	1	1	1
CBL11	176F3180	Cable brake IGBT gate signal D2h D4h	Wire harness, gatedrive card to brake IGBT	-	-	-	-	-	-	-	-	-	-	-	-	-	-	-	-	-	-	-	-
CBL12	176F3177	Cable IGBT temp to gate PCA D1h D3h	Wire harness, gatedrive card to IGBT NTC	1	1	1	1	1	1	1	1	1	1	1	1	1	1	1	1	1	1	1	1
CBL12	176F3178	Cable IGBT temp to gate PCA D2h D4h	Wire harness, gatedrive card to IGBT NTC	-	-	-	-	-	-	-	-	-	-	-	-	-	-	-	-	-	-	-	-
CBL13	176F3175	Cable IGBT gate signal D1h D3h	Wire harness, gatedrive card to IGBT gates	3	3	3	3	3	3	3	3	3	3	3	3	3	3	3	3	3	3	3	3
CBL13	176F3176	Cable IGBT gate signal D2h D4h	Wire harness, gatedrive card to IGBT gates	-	-	-	-	-	-	-	-	-	-	-	-	-	-	-	-	-	-	-	-
		Busbars																					
	176F3338	Busbar SCR AC input D1h/D3h	Busbars	3	3	3	3	3	3	3	3	3	3	3	3	3	3	3	3	3	3	3	3
	176F3339	Busbar DC+ inductor to cap bank D1h/D3h	Busbars	1	1	1	1	1	1	1	1	1	1	1	1	1	1	1	1	1	1	1	1
	176F3340	Busbar DC- inductor to cap bank D1h/D3h	Busbars	1	1	1	1	1	1	1	1	1	1	1	1	1	1	1	1	1	1	1	1
	176F3341	Busbar IGBT AC output D1h/D3h	Busbars	3	3	3	3	3	3	3	3	3	3	3	3	3	3	3	3	3	3	3	3
	176F3346	Busbar assy SCR to DC coil D1h/D3h	Busbars	1	1	1	1	1	1	1	1	1	1	1	1	1	1	1	1	1	1	1	1
	176F3347	Busbar assy curr sensor D1h/D3h	Busbars	1	1	1	1	1	1	1	1	1	1	1	1	1	1	1	1	1	1	1	1
	176F6517	Busbar assy LEM 310A curr sensor D1h/D3h	Busbars	1	1	1	1	1	1	1	1	1	1	1	1	1	1	1	1	1	1	1	1
	176F3356	Busbar motor terminals U,V,W D1h/D3h	Busbars	1	1	1	1	1	1	1	1	1	1	1	1	1	1	1	1	1	1	1	1
	176F3357	Busbar mains, no fuse, no RFI D1h/D3h	Busbars	1	1	1	1	1	1	1	1	1	1	1	1	1	1	1	1	1	1	1	1

Block Diagram Name	Spare Part Number	Spare part name	Comments	525-690 V AC (T7)																	
				D1h/D3h/D5h/D6h							D2h/D4h/D7h/D8h										
				FC 102	N75k	N90k	N110	N132	N160	N200	N250	N315	N400	N200	N250	N315	N400	N200	N250	N315	
	176F3358	Busbar mains, fuse, no RFI D1h/D3h	Busbars			1	1	1													
	176F3359	Busbar mains, RFI, no fuse D1h/D3h	Busbars			1	1	1													
	176F3360	Busbar mains, fuse, RFI D1h/D3h	Busbars			1	1	1													
	176F3368	Busbar motor terminals U,V,W D2h/D4h	Busbars			-	-	-					1	1	1						
	176F3371	Busbar mains, no fuse, no RFI D2h/D4h	Busbars			-	-	-					1	1	1						
	176F3372	Busbar mains, fuse, no RFI D2h/D4h	Busbars			-	-	-					1	1	1						
	176F3373	Busbar mains, RFI, no fuse D2h/D4h	Busbars			-	-	-					1	1	1						
	176F3374	Busbar mains, fuse, RFI D2h/D4h	Busbars			-	-	-					1	1	1						
	176F3376	Busbar SCR AC input small D2h/D4h	Busbars			-	-	-					3	3	3						
	176F3377	Busbar SCR AC input large D2h/D4h	Busbars			-	-	-					3	3	3						
	176F3378	Busbar SCR DC output small D2h/D4h	Busbars			-	-	-					2	2	2						
	176F3379	Busbar SCR DC output large D2h/D4h	Busbars			-	-	-					2	2	2						
	176F3380	Busbar DC+ SCR to DC coil D2h/D4h	Busbars			-	-	-					1	1	1						
	176F3381	Busbar DC- SCR to DC coil D2h/D4h	Busbars			-	-	-					1	1	1						
	176F3382	Busbar DC+ inductor to cap bank D2h/D4h	Busbars			-	-	-					1	1	1						
	176F3383	Busbar DC- inductor to cap bank D2h/D4h	Busbars			-	-	-					1	1	1						
	176F3384	Busbar IGBT AC output D2h/D4h	Busbars			-	-	-					3	3	3						
	176F3385	Busbar assy current sensor D2h/D4h	Busbars			-	-	-					1	1	1						
	176F3430	Busbar assy cap bank 690V D1h/D3h	Busbars			1	1	1					1	1	1						
	176F3432	Busbar assy cap bank 690V D2h/D4h	Busbars			-	-	-					1	1	1						
Other Parts																					
	176F3353	Door fan filter D4h enclosure, pkg of 10	Fan filter			21/54	21/54	21/54	21/54	21/54	21/54	21/54	21/54	21/54	21/54	21/54	21/54	21/54	21/54	21/54	
	176F3342	Air baffle D2h enclosure	Enclosure			-	-	-	-	-	-	-	21/54	21/54	21/54	21/54	21/54	21/54	21/54	21/54	
	176F3343	Air baffle D4h enclosure	Enclosure			-	-	-	-	-	-	-	IP20	IP20	IP20	IP20	IP20	IP20	IP20	IP20	
	176F3345	Cable clamp 45mm Dxh enclosure	Enclosure			4	4	4	4	4	4	4	-	-	-	-	-	-	-	-	
	176F3351	Air baffle D3h enclosure	Enclosure			IP20	IP20	IP20	IP20	IP20	IP20	IP20	-	-	-	-	-	-	-	-	
	176F3352	Air baffle D1h enclosure	Enclosure			21/54	21/54	21/54	21/54	21/54	21/54	21/54	-	-	-	-	-	-	-	-	
	176F3375	Door vent kit IP21/IP54 Dxh enclosure	Enclosure			21/54	21/54	21/54	21/54	21/54	21/54	21/54	21/54	21/54	21/54	21/54	21/54	21/54	21/54	21/54	
	176F3389	Front cover IP20 D4h enclosure	Enclosure			-	-	-	-	-	-	-	IP20	IP20	IP20	IP20	IP20	IP20	IP20	IP20	
	176F3390	Front cover IP20 D3h enclosure	Enclosure			IP20	IP20	IP20	IP20	IP20	IP20	IP20	-	-	-	-	-	-	-	-	
	176F3479	Power terminal cover IP20 D3h enclosure	Enclosure			IP20	IP20	IP20	IP20	IP20	IP20	IP20	-	-	-	-	-	-	-	-	

15

Block Diagram Name	Spare Part Number	Spare part name	Comments	525–690 V AC (T7)															
				D1h/D3h/D5h/D6h							D2h/D4h/D7h/D8h								
				FC 102	N75k	N90k	N110	N132	N160	N200	N250	N315	N400						
	176F3480	Power terminal cover IP20 D4h enclosure	Enclosure																
	176F3481	Mains shield D1h enclosure	Enclosure	21/54				21/54		21/54									
	176F3482	Mains shield D2h enclosure	Enclosure									21/54	21/54	21/54	21/54	21/54	21/54	21/54	21/54
	176F8430	Cable clamp for enclosure size D & E	Enclosure									4	4	4	4	4	4	4	4
	130B0264	Cradle for A5,B1,B2,C1 and C2 enclosure	Insulation										1	1	1	1	1	1	1
	176F3344	Bracket gatedrive support D2h/D4h	Insulation										1	1	1	1	1	1	1
	176F3348	Bracket inrush support D1h/D3h	Insulation	1	1	1	1	1	1	1	1								
	176F3349	Bracket gatedrive support D1h/D3h	Insulation	1	1	1	1	1	1	1	1								
	176F3354	Insulation mains terminals D1h/D3h	Insulation	1	1	1	1	1	1	1	1								
	176F3355	Insulation motor terminals D1h/D3h	Insulation	1	1	1	1	1	1	1	1								
	176F3361	Bracket inrush support D2h/D4h w/ 2 standoffs	Insulation										1	1	1	1	1	1	1
	176F3369	Mains terminals D2h/D4h	Insulation										1	1	1	1	1	1	1
	176F3370	Motor terminals D2h/D4h	Insulation										1	1	1	1	1	1	1
	176F3388	Cradle for LCP D1h/D3h enclosure	Insulation										1	1	1	1	1	1	1
	176F3540	Heat Sink fan cover Dxh enclosures	Enclosure	1	1	1	1	1	1	1	1								
	176F3548	Cover DC link coil large Dxh enclosure	Enclosure										1	1	1	1	1	1	1
	176F3549	Cover DC link coil small Dxh enclosure	Enclosure										1	1	1	1	1	1	1
	176F5000	Anti condensation heater Dxh enclosure	Resistor	1	1	1	1	1	1	1	1								
	176F5734	Front cover IP21/IP54 D1h enclosure	Enclosure	21/54	21/54	21/54	21/54	21/54	21/54	21/54	21/54								
	176F5735	Front cover IP21/IP54 D2h enclosure	Enclosure										21/54	21/54	21/54	21/54	21/54	21/54	21/54
	176F5736	Front cover no LCP IP21/54 D1h enclosure	Enclosure	21/54	21/54	21/54	21/54	21/54	21/54	21/54	21/54								
	176F5737	Front cover no LCP IP21/54 D2h enclosure	Enclosure										21/54	21/54	21/54	21/54	21/54	21/54	21/54
	176F5739	Extended option adaptor plate D1h enclosure	Enclosure										1	1	1	1	1	1	1
	176F5740	Extended option adaptor plate D2h enclosure	Enclosure										1	1	1	1	1	1	1
	176F5741	Gland plate D1h enclosure	Enclosure	21/54	21/54	21/54	21/54	21/54	21/54	21/54	21/54								
	176F5742	Gland plate D2h enclosure	Enclosure										21/54	21/54	21/54	21/54	21/54	21/54	21/54
	176F5748	Top plate assembly D4h	Enclosure										IP20	IP20	IP20	IP20	IP20	IP20	IP20
	176F5747	Enclosure left side D4h	Enclosure										IP20	IP20	IP20	IP20	IP20	IP20	IP20
	176F5749	Enclosure right side D4h	Enclosure										IP20	IP20	IP20	IP20	IP20	IP20	IP20
	176F6304	Front cover D2 w/ disconnect short cab.	Enclosure										21/54	21/54	21/54	21/54	21/54	21/54	21/54
	176F6313	Top terminal cover D3h inverter only	Enclosure								1								

Block Diagram Name	Spare Part Number	Spare part name	Comments	525-690 V AC (T7)																						
				D1h/D3h/D5h/D6h							D2h/D4h/D7h/D8h															
				FC 102	N75k	N90k	N110	N132	N160	N200	N250	N315	N400	FC 103	N75k	N90k	N110	N132	N160	N200	N250	N315	N400			
	176F6314	Top terminal cover D4h inverter only	Enclosure																							

Table 15.10 Spare Parts List, D1h–D8h Drives, 525–690 V AC (T7)

15

Block Diagram Name	Spare Part Number	Spare part name	Comments	380–480/500 VAC (T4/T5)							
				FC 102 (T4)	N355	N400	N450	E1h/E3h	E2h/E4h		
		Control Cards									
PCA1	130B1151	Control Card, FC102	coated, no safe stop		102	102	102	102	102	102	102
PCA1	134B1730	Control Card, FC102	coated, no safe stop, Ver 2 card		102	102	102	102	102	102	102
PCA1	130B1150	Control Card, FC102	coated, safe stop		102	102	102	102	102	102	102
PCA1	134B1729	Control Card, FC102	coated, safe stop, Ver 2 card		102	102	102	102	102	102	102
PCA1	130B6968	Control Card, FC103	coated, no safe stop		103	103	103	103	103	103	103
PCA1	134B1724	Control Card, FC103	coated, no safe stop, Ver 2 card		103	103	103	103	103	103	103
PCA1	130B6967	Control Card, FC103	coated, safe stop		103	103	103	103	103	103	103
PCA1	134B1714	Control Card, FC103	coated, safe stop, Ver 2 card		103	103	103	103	103	103	103
PCA1	130B1168	Control Card, FC202	coated, no safe stop		202	202	202	202	202	202	202
PCA1	134B1732	Control Card, FC202	coated, no safe stop, Ver 2 card		202	202	202	202	202	202	202
PCA1	130B1167	Control Card, FC202	coated, safe stop		202	202	202	202	202	202	202
PCA1	134B1731	Control Card, FC202	coated, safe stop, Ver 2 card		202	202	202	202	202	202	202
PCA1	130B1109	Control Card, FC302	coated, safe stop		302	302	302	302	302	302	302
PCA1	134B1726	Control Card, FC302	coated, safe stop, Ver 2 card		302	302	302	302	302	302	302
		Printed Circuit Cards									
PCA2	176F6625	Power card high power	S/W preloaded, all power sizes, conformal coated, no scaling card		1	1	1	1	1	1	1
PCA3	176F3415	Current scaling card 2.67 ohm	Installs on the power card		1	-	-	-	-	-	-
PCA3	176F6628	Current scaling card 2.45 ohm	Installs on the power card		-	1	-	-	-	-	-
PCA3	176F6629	Current scaling card 2.18 ohm	Installs on the power card		-	-	1	-	-	-	-
PCA3	176F6630	Current scaling card 2.02 ohm	Installs on the power card		-	-	-	1	-	-	-
PCA3	176F6631	Current scaling card 1.83 ohm	Installs on the power card		-	-	-	-	1	-	-
PCA4	176F6623	Inrush card 400V	Mounts on the SCR/diode modules		1	1	1	1	1	1	1
PCA5	176F6621	Gatedrive card 400V	Gatedrive card includes brake		1	1	1	1	1	1	1
PCA6A	176F6626	RFI card diff high power	Circuit board in the RFI filter		1	1	1	1	1	1	1
PCA7	176F3161	Balance/HF card NO 110-560kW 400V	Combined high frequency and balance card		1	1	1	1	1	1	1
PCA16	176F6638	Fan power card high power	Fan power card for E-sized drives		1	1	1	1	1	1	1
		Semiconductors									
IGBT1,2,3,4,5,6	176F6641	IGBT module 600A T4/T5	IGBT module, 1 per kit		6	6	6	6	6	6	6
IGBT1,2,3,4,5,6	176F6642	IGBT module 900A T4/T5	IGBT module, 1 per kit		-	-	-	-	-	-	6
IGBT7,8	176F6645	IGBT brake module 450A E1,E3	Brake IGBT module, 1 per kit		2	2	2	2	2	2	-

Block Diagram Name	Spare Part Number	Spare part name	Comments	380-480/500 VAC (T4/T5)														
				E1h/E3h				E2h/E4h										
				FC 102 (T4)	N355	N400	N450	FC 103 (T4)	N355	N400	N450	FC 202 (T4)	N355	N400	N450	FC 302 (T5)	N315	N355
IGBT7,8	176F6646	IGBT brake module 450A E2,E4	Brake IGBT module, 1 per kit															
SCR1,2,3	176F6647	Rectifier SCR/diode 700AMP 1600V	SCR/diode, 1 per kit															
		Capacitors																
CBANK1	176F6634	Capacitor T5	Individual DC bus capacitor, 1 per kit															
C1,2,3,4,5,6	176F8323	IGBT snubber cap 1000V 1.5UF	IGBT snubber cap, mounts on IGBT modules															
C1,2,3,4,5,6	176F3162	IGBT snubber cap 1000V 1.5uF wide mount	IGBT snubber cap, mounts on IGBT modules															
		Fans																
F2	176F6637	Fan, heat sink, UL 12 P4001	Fan, heat sink, high speed, 172X51mm, 48VDC															
F1	176F3167	Top fan IP20 DC 80X38 48VDC	Fan, IP20, door, 80x38mm, 48VDC															
F4	176F6636	Fan, top/door P4001 E1h-E4h	Door fan, E1h-E4h, 120X38mm, 48VDC															
		Fuses																
FU1,2,3	176F6639	Fuse, main, 1250A, 700V	Mains fuse, 1 per kit															
		Inductors and Current Sensors																
CT1,2,3	176F6633	Current sensor 1000A	LEM LF1010-S-SPA1, 1 per kit															
L1	176F6730	DC link coil 47uH	DC inductor															
L1	176F6731	DC link coil 42uH	DC inductor															
L1	176F6732	DC link coil 28uH	DC inductor															
		Disconnects																
SW1	176F6315	Switch, disc,800A,690V	Main disconnect															
SW1	176F6735	Switch, disc,1200A,690V	Main disconnect															
SW1	176F9189	Double disc, handle & rod E frm LHD/AAF	Double disc handle & 12x165 mm shaft															
		Cables																
CBL1	176F3181	Cable LCP to control card D1h D3h	DB9 extension cable assembly															
CBL2	176F3183	Cable control card to power card D1H D3H	Cable, control card to power card															
CBL3	176F6651	Assy, wire, CBL3, P4001 ,pwr-mixing, E1	Wire harness, power card to mixing fans															
CBL3	176F6652	Assy, wire, CBL3, P4001, pwr-mixing, E2	Wire harness, power card to mixing fans															
CBL4	176F6653	Assy, wire, CBL4, P4001, pwr-CT, E1h	Wire harness, power card to current sensors															
CBL4	176F6654	Assy, wire, CBL4, P4001, pwr-CT, E2h	Wire harness, power card to current sensors															
CBL5	176F6693	Assy, wire, CBL5, P4001, DC-pwr, E1h	Wire harness, DC bus to fan power supply															
CBL5	176F6694	Assy, wire, CBL5, P4001, DC-pwr, E2h	Wire harness, DC bus to fan power supply															
CBL6	176F3790	Assy, wire, CBL6, P4001, pwr-RFI, E1h	Wire harness, power card to HF and RFI															

Block Diagram Name	Spare Part Number	Spare part name	Comments	380–480/500 VAC (T4/T5)										
				E1h/E3h				E2h/E4h						
				N355	N400	N450	N500	N355	N400	N450	N500			
CBL6	176F3791	Assy, wire, CBL6, P4001, pwr-RFI, E2h	Wire harness, power card to HF and RFI											
CBL7	176F6695	Assy, wire, CBL7, P4001, pwr-GD, E1h	Ribbon cable, power card to gatedrive card											
CBL7	176F6696	Assy, wire, CBL7, P4001, pwr-GD, E2h	Ribbon cable, power card to gatedrive card											
CBL8	176F6697	Assy, wire, CBL8, P4001, pwr-FPC/inrush, E1	Wire harness, intrush card to fan power supply											
CBL8	176F6698	Assy, wire, CBL8, P4001, pwr-FPC/inrush, E2h	Wire harness, intrush card to fan power supply											
CBL10	176F6699	Assy, wire, CBL10, P4001, intrush-SCR, E1	Wire harness, intrush card to SCR modules											
CBL10	176F6702	Assy, wire, CBL10, P4001, intrush-SCR, E2h	Wire harness, intrush card to SCR modules											
CBL11	176F6703	Assy, wire, CBL11, P4001, GD-brake, E1h	Wire harness, gatedrive to brake IGBT											
CBL11	176F6704	Assy, wire, CBL11, P4001, GD-brake, E2	Wire harness, gatedrive to brake IGBT											
CBL12	176F6705	Assy, wire, CBL12, P4001, GD-NTC, E1h	Wire harness, gatedrive to IGBT thermal sensor, 1 per kit											
CBL12	176F6706	Assy, wire, CBL12, P4001, GD-NTC, E2h	Wire harness, gatedrive to IGBT thermal sensor, 1 per kit											
CBL13	176F6707	Assy, wire, CBL13, P4001, GD-IGBT, E1h	Wire harness, gatedrive to IGBT module, 1 per kit											
CBL13	176F6708	Assy, wire, CBL13, P4001, GD-IGBT, E2h	Wire harness, gatedrive to IGBT module, 1 per kit											
CBL14	176F6709	Assy, wire, CBL14, P4001, DC-FPC, E1h	Wire harness, DC bus to fan power card											
CBL15	176F6655	Assy, wire, CBL15, P4001, FPC-HS, E1h	Wire harness, fan power card to heat sink fans											
CBL15	176F6656	Assy, wire, CBL15, P4001, FPC-HS, E2h	Wire harness, fan power card to heat sink fans											
CBL17	176F6657	Assy, wire, CBL17, P4001, FPC-top, E1hE2h, IP20	Wire harness, fan power card to top fans, IP20											
CBL17	176F6658	Assy, wire, CBL17, P4001, FPC-door, E1hE2h, IP54	Wire harness fan power card to door fans, IP21/IP54											
		Terminal, Labels, Insulators												
TB1	176F6686	Terminal suppt, main, motor, E1h–E4h	Mains term insulation block, black plastic	3	3	3	3	3	3	3	3	3	3	3
TB2	176F6686	Terminal suppt, main, motor, E1h–E4h	Motor term insulation block, black plastic	3	3	3	3	3	3	3	3	3	3	3
	176F6677	Insul, plas, active intrush, E1h–E4h	Bracket intrush support; mounts above SCRs	1	1	1	1	1	1	1	1	1	1	1
	176F6672	Insul, plas, PC, GD, PCA, support, P4001	Bracket gatedrive support; mounts above IGBTs	1	1	1	1	1	1	1	1	1	1	1
		Busbars												
	176F6680	Busbar, SCR AC input, E1h,E3h	Mains busbars to SCRs	3	3	3	3	3	3	3	3	3	3	3
	176F6681	Busbar, SCR AC input, E2h,E4h	Mains busbars to SCRs											
	176F6663	Busbar, DClink SCR multi, E1h,E3h, N315,N355	Connects SCR to DC coil; +/- busbars & Mylar assy	1	1	1	1	1	1	1	1	1	1	1
	176F6661	Busbar, DClink SCR multi, E1h,E3h, N400	Connects SCR to DC coil; +/- busbars & Mylar assy											
	176F6662	Busbar, DClink SCR multi, E2h,E4h	Connects SCR to DC coil; +/- busbars & Mylar assy											
	176F6675	Busbar, AC input to intrush PCA, E1,E2	Set of 3 small AC busbars to intrush card	1	1	1	1	1	1	1	1	1	1	1
	176F6676	Busbar, AC input to intrush PCA, E2,E3	Set of 3 small AC busbars to intrush card											

Block Diagram Name	Spare Part Number	Spare part name	Comments	380–480/500 VAC (T4/T5)						
				E1h/E3h		E2h/E4h				
				FC 102 (T4)	N355	N400	N450	N500	N560	
				FC 103 (T4)	N355	N400	N450	N500	N560	
				FC 202 (T4)	N355	N400	N450	N500	N560	
				FC 302 (T5)	N315	N355	N400	N450	N500	
	176F6692	Tool, capacitor removal/installation	Tool to remove DC bus caps		1	1	1	1	1	1

Table 15.11 Spare Parts List, E1h–E4h Drives, 380–480/500 V AC (T4/T5)

Block Diagram Name	Spare Part Number	Spare part name	Comments	525–690 VAC (T7)																				
				E1h/E3h						E2h/E4h														
				FC 102	N450	N500	N560	N630	N800	FC 103	N450	N500	N560	N630	N800									
		Control Cards																						
PCA1	130B1151	Control Card, FC102	coated, no safe stop																					
PCA1	134B1730	Control Card, FC102	coated, no safe stop, Ver 2 card																					
PCA1	130B1150	Control Card, FC102	coated, safe stop																					
PCA1	134B1729	Control Card, FC102	coated, safe stop, Ver 2 card																					
PCA1	130B6968	Control Card, FC103	coated, no safe stop																					
PCA1	134B1724	Control Card, FC103	coated, no safe stop, Ver 2 card																					
PCA1	130B6967	Control Card, FC103	coated, safe stop																					
PCA1	134B1714	Control Card, FC103	coated, safe stop, Ver 2 card																					
PCA1	130B1168	Control Card, FC202	coated, no safe stop																					
PCA1	134B1732	Control Card, FC202	coated, no safe stop, Ver 2 card																					
PCA1	130B1167	Control Card, FC202	coated, safe stop																					
PCA1	134B1731	Control Card, FC202	coated, safe stop, Ver 2 card																					
PCA1	130B1109	Control Card, FC302	coated, safe stop																					
PCA1	134B1726	Control Card, FC302	coated, safe stop, Ver 2 card																					
		Printed Circuit Cards																						
PCA2	176F6625	Power card high power	S/W preloaded, all power sizes, conformal coated, no scaling card																					
PCA3	176F3413	Current scaling card 4.02 ohm	Installs on the power card																					
PCA3	176F3154	Current scaling card 3.82 ohm	Installs on the power card																					
PCA3	176F3155	Current scaling card 3.11 ohm	Installs on the power card																					
PCA3	176F3415	Current scaling card 2.67 ohm	Installs on the power card																					
PCA3	176F6628	Current scaling card 2.45 ohm	Installs on the power card																					
PCA3	176F6632	Current scaling card 2.13 ohm	Installs on the power card																					
PCA4	176F6624	Inrush card 690V	Mounts on the SCR/diode modules																					
PCA5	176F6622	Gatedrive card 690V	Gatedrive card includes brake																					
PCA7	176F3419	Balance/HF card NO 75-800kW 690V	Combined high frequency and balance card																					
PCA16	176F6638	Fan power card high power	Fan power card for E-sizes drives																					
		Semiconductors																						
IGBT1,2,3,4,5,6	176F6643	IGBT module 600A 1700V T7	IGBT module, 1 per kit																					
IGBT1,2,3,4,5,6	176F6644	IGBT module 650A 1700V T7	IGBT module, 1 per kit																					

Block Diagram Name	Spare Part Number	Spare part name	Comments	525–690 VAC (T7)											
				E1h/E3h			E2h/E4h								
				FC 102	N450	N500	N560	N630	N710	N800					
IGBT7,8	176F6645	IGBT module 450A 1700V E1,E3 brake	IGBT module, 1 per kit		2	2	2	2	2	2	2	2	2		
IGBT7,8	176F6646	IGBT module 450A 1700V E2, E4 brake	Brake IGBT module, 1 per kit		–	–	–	–	–	–	–	–	–		
SCR1,2,3	176F6648	Rectifier SCR 650A 2200V T7	SCR, 1 per kit		3	3	3	3	3	3	3	3	3		
Capacitors															
CBANK1	176F6635	Capacitor T7	Individual DC bus capacitor, 1 per kit		15	15	15	18	18	18	21	21	21		
C1,2,3,4,5,6	176F8534	IGBT snubber cap 1uF 1250V	IGBT snubber cap. mounts on IGBT modules		6	6	6	6	6	6	–	–	–		
C1,2,3,4,5,6	176F3427	IGBT snubber cap 1uF 1250V wide mount	IGBT snubber cap. mounts on IGBT modules		–	–	–	–	–	–	–	–	–		
Fans															
F2	176F6637	Fan, heat sink, UL 12 P4001	Fan, heat sink, high speed, 172x51mm, 48VDC		3	3	3	3	3	3	3	3	3		
F1	176F3167	Top fan IP20 DC 80x38	Fan, IP20, door, 80x38mm, 48VDC		2	2	2	2	2	2	2	2	2		
F4	176F6636	Fan, top/door P4001 E1h–E4h	Door fan, E1h–E4h, 120x38mm, 48VDC		2	2	2	2	2	2	2	2	2		
Fuses															
FU1,2,3	176F6640	Fuse, T7 P4001	Fuse, size 4, 1250a,700v,170m series		3	3	3	3	3	3	3	3	3		
Inductors and Current Sensors															
CT1,2,3	176F6633	Current sensor 1000A	LEM LF1010-S-SPA1, 1 per kit		3	3	3	3	3	3	3	3	3		
L1	176F6733	DC link coil 65uH	DC inductor		1	1	–	–	–	–	–	–	–		
L1	176F6734	DC link coil 50uH	DC inductor		–	–	–	1	1	1	–	–	–		
L1	176F6732	DC link coil 28uH	DC inductor		–	–	–	–	–	–	–	1	1		
Disconnects															
SW1	176F6315	Switch, disc, 800A, 690V	Main disconnect		1	1	1	1	1	1	–	–	–		
SW1	176F6735	Switch, disc, 1200A, 690V	Main disconnect		–	–	–	–	–	–	–	1	1		
SW1	176F9189	Double disc, handle & rod E frm LHD/AAF	Double disc handle & 12x165 mm shaft		1	1	1	1	1	1	1	1	1		
Cables															
CBL1	176F3181	Cable LCP to control card D1h D3h	DB9 extension cable assembly		1	1	1	1	1	1	1	1	1		
CBL2	176F3183	Cable control card to power card D1H D3H	Cable, control card to power card		1	1	1	1	1	1	1	1	1		
CBL3	176F6651	Assy, wire, CBL3, P4001, pwr-mixing, E1h	Wire harness, power card to mixing fans		1	1	1	1	1	1	–	–	–		
CBL3	176F6652	Assy, wire, CBL3, P4001, pwr-mixing, E2h	Wire harness, power card to mixing fans		–	–	–	–	–	–	–	1	1		
CBL4	176F6653	Assy, wire, CBL4, P4001, pwr-CT, E1h	Wire harness, power card to current sensors		1	1	1	1	1	1	–	–	–		
CBL4	176F6654	Assy, wire, CBL4, P4001, pwr-CT, E2h	Wire harness, power card to current sensors		–	–	–	–	–	–	–	1	1		
CBL5	176F6693	Assy, wire, CBL5, P4001, DC-pwr, E1h	Wire harness, DC bus to fan power supply		1	1	1	1	1	1	–	–	–		
CBL5	176F6694	Assy, wire, CBL5, P4001, DC-pwr, E2h	Wire harness, DC bus to fan power supply		–	–	–	–	–	–	–	1	1		

Block Diagram Name	Spare Part Number	Spare part name	Comments	525-690 VAC (T7)																				
				E1h/E3h					E2h/E4h															
				FC 102	N450	N500	N560	N630	FC 103	N450	N500	N560	N630	FC 202	N450	N500	N560	N630	FC 302	N355	N400	N500	N560	N630
CBL6	176F3790	Assy, wire, CBL6, P4001, pwr-RFI, E1h	Wire harness, power card to HF and RFI																					
CBL6	176F3791	Assy, wire, CBL6, P4001, pwr-RFI, E2h	Wire harness, power card to HF and RFI																					
CBL7	176F6695	Assy, wire, CBL7, P4001, pwr-GD, E1h	Ribbon cable, power card to gatedrive card																					
CBL7	176F6696	Assy, wire, CBL7, P4001, pwr-GD, E2h	Ribbon cable, power card to gatedrive card																					
CBL8	176F6697	Assy, wire, CBL8, P4001, pwr-FPC/inrush, E1h	Wire harness, inrush card to fan power supply																					
CBL8	176F6698	Assy, wire, CBL8, P4001, pwr-FPC/inrush, E2h	Wire harness, inrush card to fan power supply																					
CBL10	176F6699	Assy, wire, CBL10, P4001, inrush-SCR, E1h	Wire harness, inrush card to SCR modules																					
CBL10	176F6702	Assy, wire, CBL10, P4001, inrush-SCR, E2h	Wire harness, inrush card to SCR modules																					
CBL11	176F6703	Assy, wire, CBL11, P4001, GD-brake, E1h	Wire harness, gatedrive to brake IGBT																					
CBL11	176F6704	Assy, wire, CBL11, P4001, GD-brake, E2	Wire harness, gatedrive to brake IGBT																					
CBL12	176F6705	Assy, wire, CBL12, P4001, GD-NTC, E1h	Wire harness, gatedrive to IGBT thermal sensor, 1 per kit																					
CBL12	176F6706	Assy, wire, CBL12, P4001, GD-NTC, E2h	Wire harness, gatedrive to IGBT thermal sensor, 1 per kit																					
CBL13	176F6707	Assy, wire, CBL13, P4001, GD-IGBT, E1h	Wire harness, gatedrive to IGBT module, 1 per kit																					
CBL13	176F6708	Assy, wire, CBL13, P4001, GD-IGBT, E2h	Wire harness, gatedrive to IGBT module, 1 per kit																					
CBL14	176F6709	Assy, wire, CBL14, P4001, DC-FPC, E1h	Wire harness DC Bus to fan power card																					
CBL15	176F6655	Assy, wire, CBL15, P4001, FPC-HS, E1h	Wire harness, fan power card to heat sink fans																					
CBL15	176F6656	Assy, wire, CBL15, P4001, FPC-HS, E2h	Wire harness, fan power card to heat sink fans																					
CBL17	176F6657	Assy, wire, CBL17, P4001, FPC-top, E1hE2h, IP20	Wire harness, fan power card to top fans, IP20																					
CBL17	176F6658	Assy, wire, CBL17, P4001, FPC-door, E1hE2h, IP54	Wire harness, fan power card to door fans, IP21/IP54																					
Terminals, Labels, Insulators																								
TB1	176F6686	Terminal suppt, main, motor, E1h-E4h	Mains term insulation block, black plastic																					
TB2	176F6686	Terminal suppt, main, motor, E1h-E4h	Motor term insulation block, black plastic																					
	176F6677	Insul, plas, active inrush, E1h-E4h	Bracket inrush support, mounts above SCRs																					
	176F6672	Insul, plas, PC, GD, PCA, support, P4001	Bracket gatedrive support, mounts above IGBTs																					
Busbars																								
	176F6680	Busbar, SCR AC input, E1h, E3h	Mains busbars to SCRs																					
	176F6681	Busbar, SCR AC input, E2h,E4h	Mains busbars to SCRs																					
	176F6663	Busbar, DC link SCR multi, E1hE3h, N315,N355	Connects SCR to DC coil; +/- busbars & Mylar assy																					
	176F6662	Busbar, DC link SCR multi, E2h,E4h	Connects SCR to DC coil; +/- busbars & Mylar assy																					
	176F6675	Busbar, AC input to inrush PCA, E1,E2	Set of 3 small AC busbars to inrush card																					
	176F6676	Busbar, AC input to inrush PCA, E2,E3	Set of 3 small AC busbars to inrush card																					

Block Diagram Name	Spare Part Number	Spare part name	Comments	525–690 VAC (T7)											
				E1h/E3h						E2h/E4h					
				FC 102	N450	N500	N560	N630	N710	N800	FC 103	N450	N500	N560	N630
	176F6664	Busbar, DC neg, DC link ind to CAPB, E1,E3	Connects DC coil - input to cap bank, right side of drive		1	1	1	1	1	1	1	1	1	1	1
	176F6665	Busbar, DC neg, DC link ind to CAPB, E2,E4	Connects DC coil - input to cap bank, right side of drive		-	-	-	-	-	-	-	-	-	-	-
	176F6666	Busbar, DC pos, DC link ind to CAPB, E1,E2	Connects DC coil + input to cap bank, left side of drive		1	1	1	1	1	1	1	1	1	1	1
	176F6667	Busbar, DC pos, DC link ind to CAPB, E2,E4	Connects DC coil + input to cap bank, left side of drive		-	-	-	-	-	-	-	-	-	-	-
	176F6684	Busbar insulator set, T7 E1 P4001	Set of 3 cap bank busbars with Mylar insulators		1	1	1	1	1	1	1	1	1	1	1
	176F6685	Busbar insulator set, T7 E2 P4001	Set of 3 cap bank busbars with Mylar insulators		-	-	-	-	-	-	-	-	-	-	-
	176F6673	Busbar, IGBT AC OUTPUT, E1,E3	IGBT AC output, goes over the IGBT, 1 per kit		3	3	3	3	3	3	3	3	3	3	3
	176F6674	Busbar, IGBT AC OUTPUT, E2,E4	IGBT AC output, goes over the IGBT, 1 per kit		-	-	-	-	-	-	-	-	-	-	-
	176F6659	Busbar, current sensor, E1hE3h	Busbars through sensors, 1 per kit		1	1	1	1	1	1	1	1	1	1	1
	176F6660	Busbar, current sensor, E2hE4h	Busbars through sensors, 1 per kit		-	-	-	-	-	-	-	-	-	-	-
	176F3839	Busbar, motor, U, E1hE3h	Busbar, connects C/T bar to right angle bar		1	1	1	1	1	1	1	1	1	1	1
	176F3840	Busbar, motor, V, E1hE3h	Busbar, connects C/T bar to right angle bar		1	1	1	1	1	1	1	1	1	1	1
	176F3841	Busbar, motor, W, E1hE3h	Busbar, connects C/T bar to right angle bar		1	1	1	1	1	1	1	1	1	1	1
	176F3844	Busbar, motor, U, E2hE4h	Busbar, connects C/T bar to right angle bar		-	-	-	-	-	-	-	-	-	-	-
	176F3846	Busbar, motor, V, E2hE4h	Busbar, connects C/T bar to right angle bar		-	-	-	-	-	-	-	-	-	-	-
	176F3845	Busbar, motor, W, E2hE4h	Busbar, connects C/T bar to right angle bar		-	-	-	-	-	-	-	-	-	-	-
TB1	176F6689	Busbar terminal, E1h–E4h	Mains terminal busbars (L1,L2,L3)		3	3	3	3	3	3	3	3	3	3	3
TB2	176F6689	Busbar terminal, E1h–E4h	Motor terminal busbars (U,V,W)		3	3	3	3	3	3	3	3	3	3	3
		Other Parts													
	176F3353	Door fan filter Dh frame package of 10	IP21/IP54 door filter 2 per drive, 10 per kit		2	2	2	2	2	2	2	2	2	2	2
	176F3375	Door vent kit IP21/IP54 Dh frame	Door vent kit, no fan		2	2	2	2	2	2	2	2	2	2	2
TB1	176F6686	Terminal suppt, main, motor, E1h–E4h	Mains terminal insulation block		3	3	3	3	3	3	3	3	3	3	3
TB2	176F6686	Terminal suppt, main, motor, E1h–E4h	Motor terminal insulation block		3	3	3	3	3	3	3	3	3	3	3
	176F6668	Cover, E3h front, top panel	Front cover IP20 E3h		IP20	IP20	IP20	IP20	IP20	IP20	IP20	IP20	IP20	IP20	IP20
	176F6669	Cover, E3h front, lower panel	Front cover IP20 E3h		IP20	IP20	IP20	IP20	IP20	IP20	IP20	IP20	IP20	IP20	IP20
	176F6670	Cover, E4h front, top panel	Front cover IP20 E4h		-	-	-	-	-	-	-	-	-	-	-
	176F6671	Cover, E4h front, lower panel	Front cover IP20 E4h		-	-	-	-	-	-	-	-	-	-	-
	176F6678	Cover, mains shield covers, E1	Mains shield E1		1	1	1	1	1	1	1	1	1	1	1
	176F6679	Cover, mains shield covers, E2	Mains shield E2		-	-	-	-	-	-	-	-	-	-	-

Block Diagram Name	Spare Part Number	Spare part name	Comments	525-690 VAC (T7)																
				E1h/E3h				E2h/E4h												
				FC 102	FC 103	FC 202	FC 302	N450	N500	N560	N630	N710	N800							
	176F6692	Tool, capacitor removal/installation	Tool to remove DC bus caps																	

Table 15.12 Spare Parts List, E1h-E4h Drives, 525-690 V AC (T7)

16 Block Diagrams

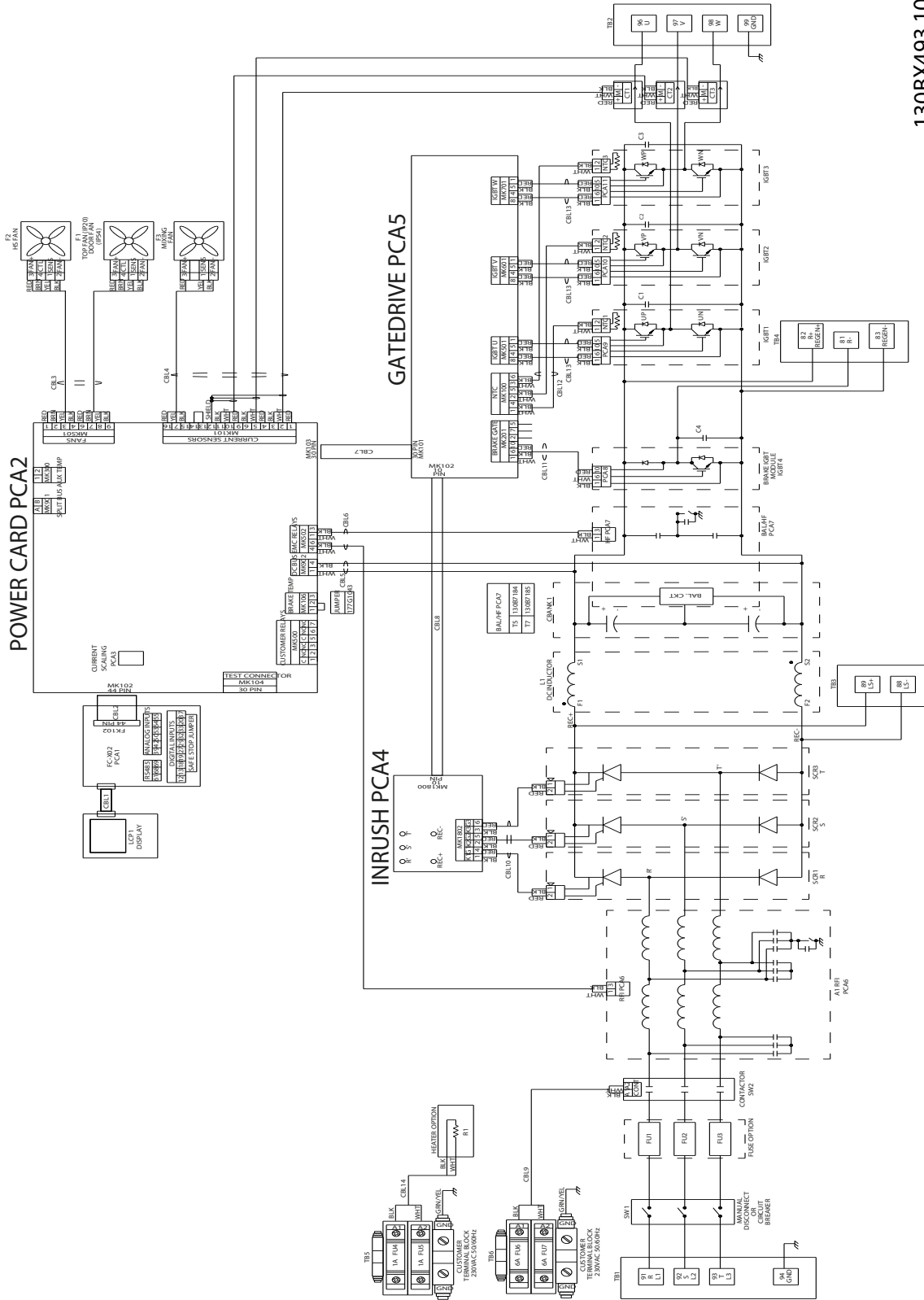

130BX493.10

Illustration 16.1 Electrical Block Diagram of D1h–D8h Units

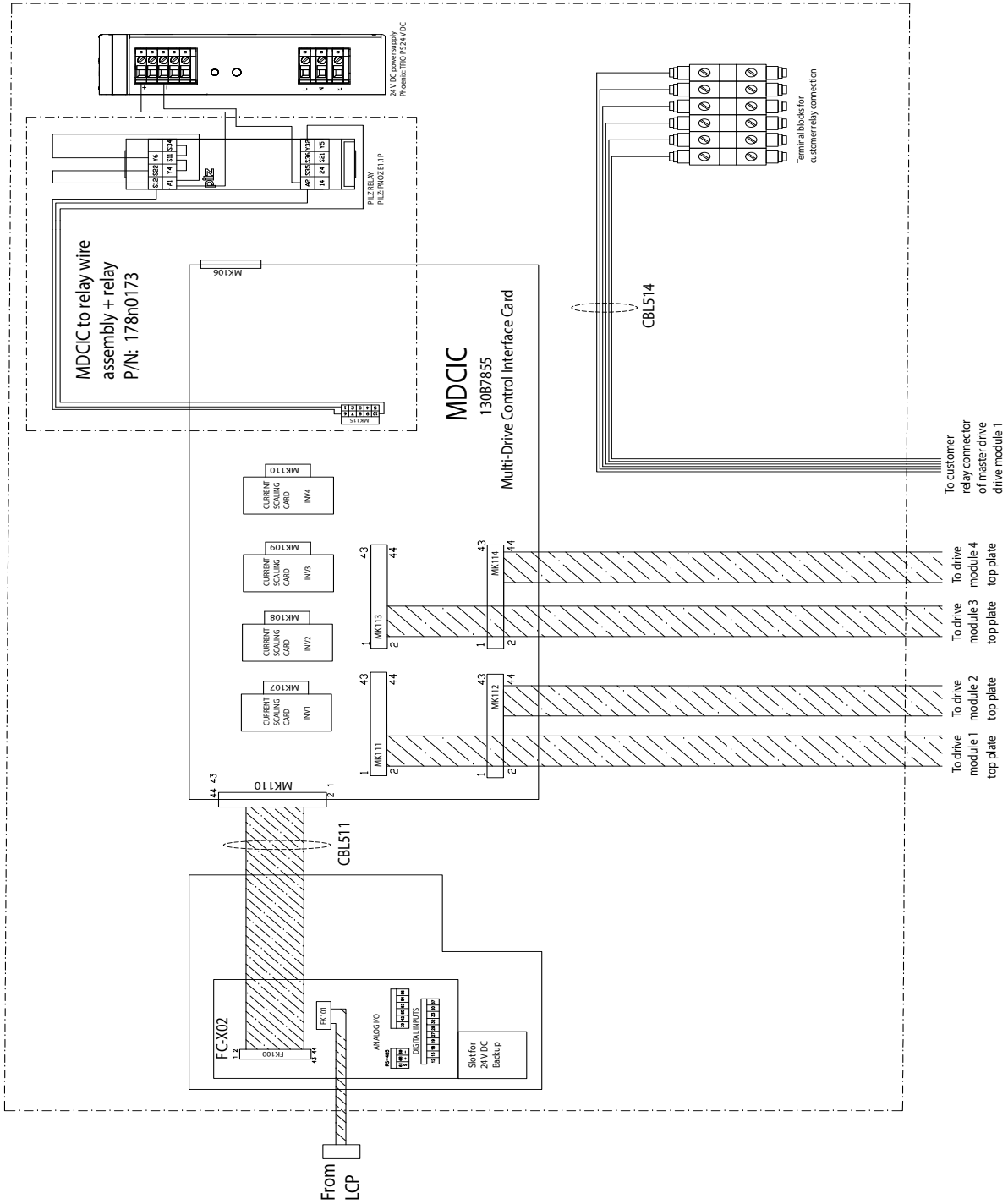

130BF090.10

Illustration 16.2 Internal Block Diagram of Control Shelf for Parallel Drive System

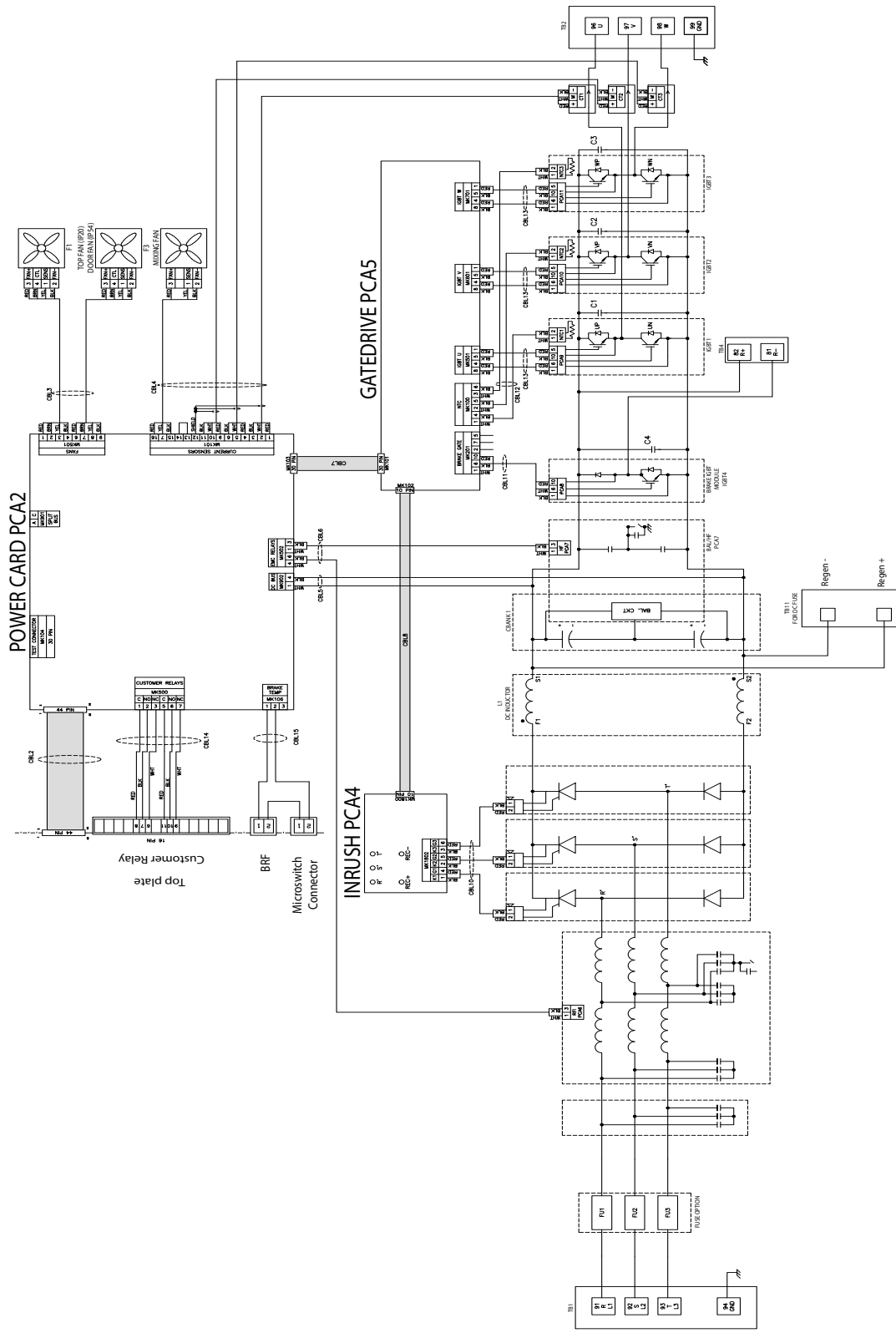

130BF087.10

Illustration 16.3 Internal Block Diagram of Parallel Drive Module

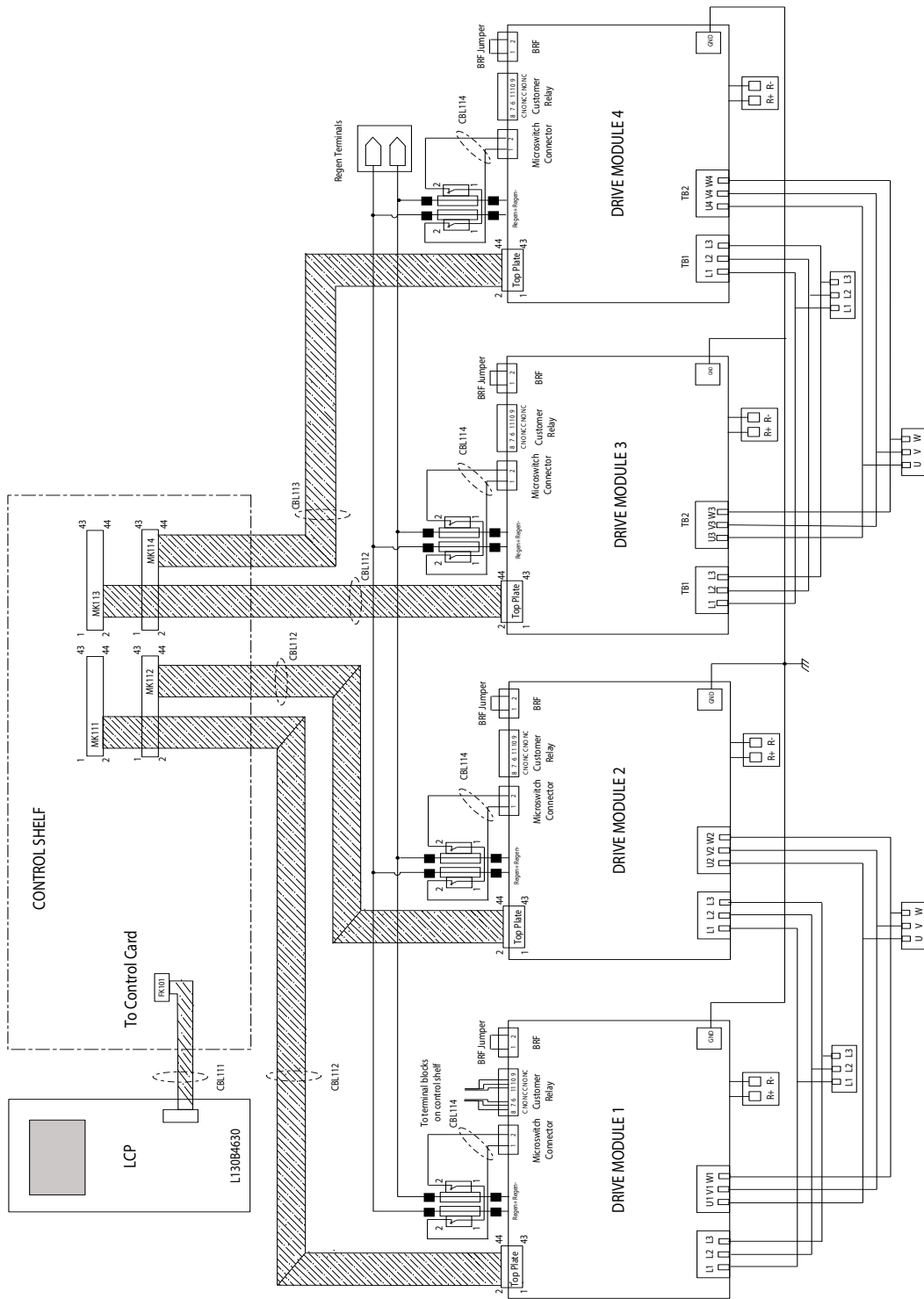

130BF056.10

Illustration 16.4 Block Diagram of a 4-module System

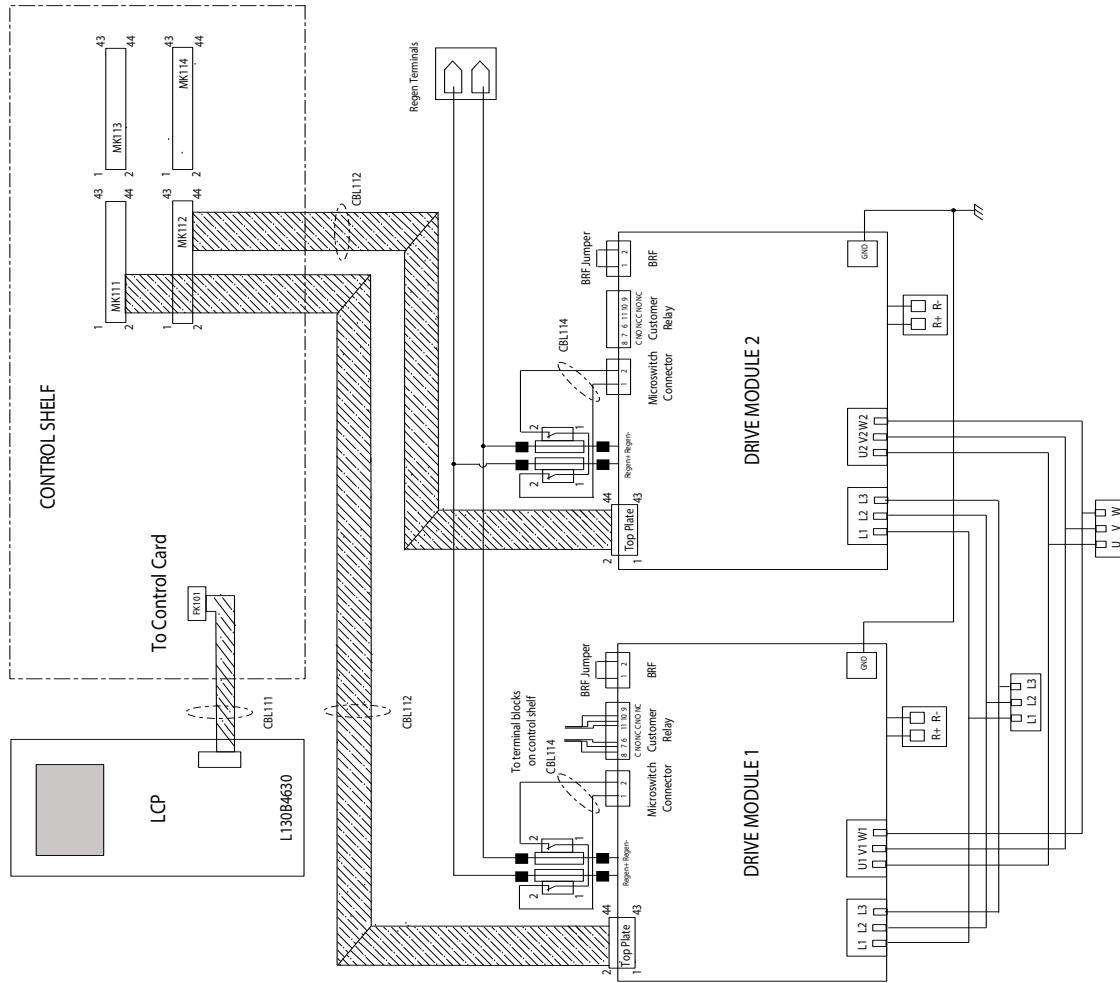

130BF057.10

Illustration 16.5 Block Diagram of a 2-module System

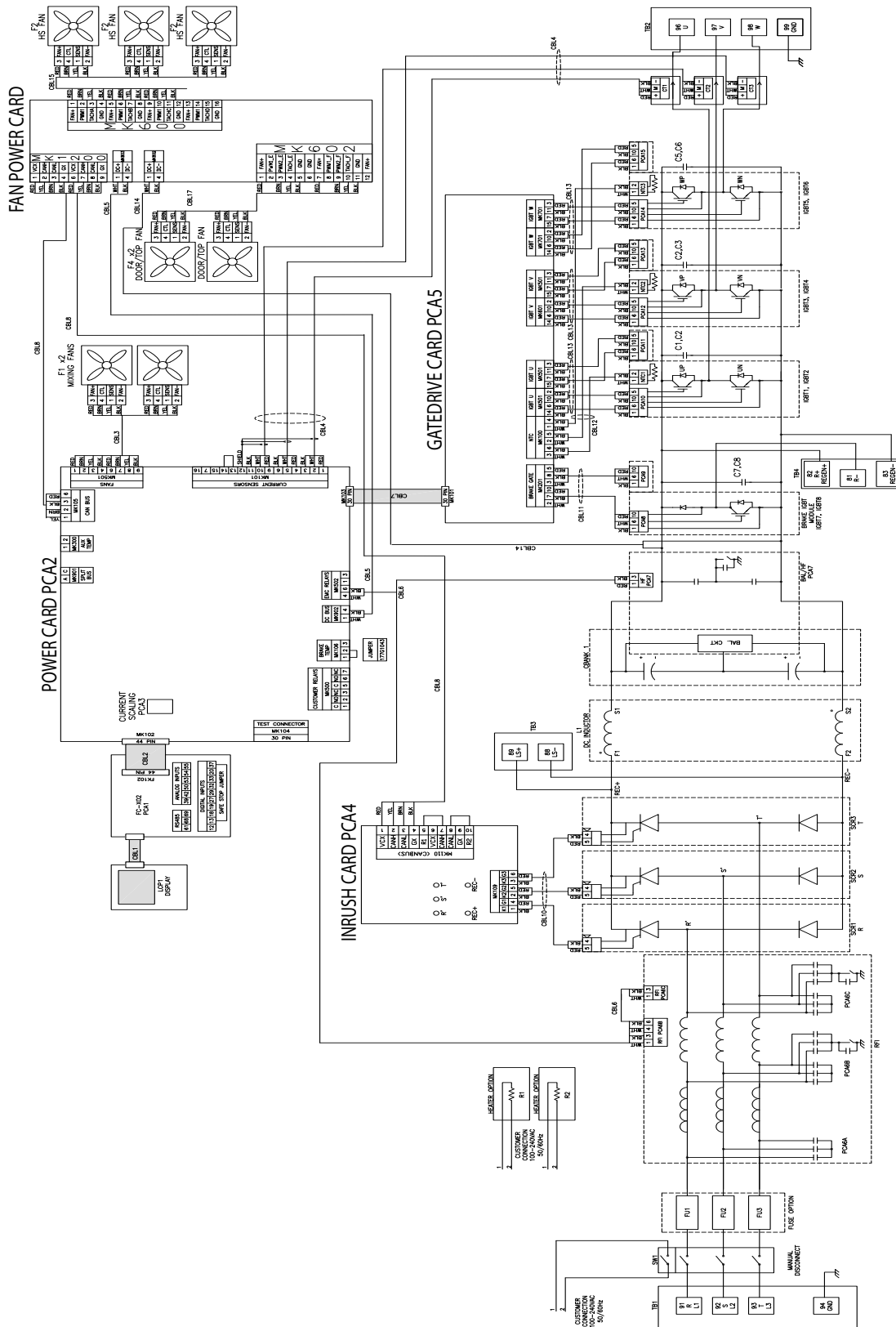

1308F750.10

Illustration 16.6 Electrical Block Diagram of E1h-E4h Units

Index

A

Abbreviations..... 10

Air baffle..... 136, 192

Alarms

- Codes..... 66
- List of..... 68
- Log..... 31, 77
- Trip points..... 321, 322

Analog

- Input and output..... 82

Anti-condensation heater..... 29

Authorized personnel..... 12

Auto on..... 31, 34, 37

Auto reset..... 30

Automatic motor adaptation (AMA)

- Auto tune..... 82
- Status..... 34
- Warning..... 74

B

Balance card..... 146

Balance/high frequency card..... 291

Blank mounting plate..... 258

Block diagram

- Basic..... 43
- Control shelf..... 357
- D1h–D8h..... 356
- E1h–E4h..... 361
- Parallel drive module..... 358
- Parallel drive system..... 359, 360

Brake

- Control..... 69
- IGBT module..... 152, 230
- Location..... 29
- Overview..... 55
- Resistor..... 68
- Status..... 34
- Terminal..... 141, 196
- Testing..... 101

Brake busbars..... 311, 313

Brake resistor

- Warning..... 71

Busbar

- AC input..... 275
- Current sensor..... 289
- DC bus rails..... 317
- Horizontal brake..... 313
- IGBT output busbar..... 289
- Inrush busbar..... 271
- Motor busbar..... 289
- Motor busbar assembly..... 289
- Rectifier bus plate..... 271
- SCR input busbar..... 273
- Vertical brake..... 311

Busbars

- AC input..... 136, 137, 192, 193
- SCR input..... 150, 209

C

Cable routing..... 87

Certifications..... 11

Circuit breaker..... 29, 104

Circuitry..... 82, 119

Coil..... 81

Configuration..... 82

Contactor

- Coil..... 104
- Illustration..... 242
- Removal..... 182
- Testing..... 104

Control

- Local..... 30, 31, 34
- Logic..... 82
- Signal..... 34
- Terminal..... 31, 34, 37, 44, 82

Control card

- Ambient trip..... 322
- Function..... 44
- Logic..... 44
- Mounting plate..... 130, 188, 261
- Parallel drive module..... 257
- Removal..... 130, 261
- Testing..... 107
- Warning..... 75

Control shelf

- Block diagram..... 357
- Electromagnetic compatibility..... 254
- Illustration..... 25
- Installation..... 253
- Removal..... 249

Conventions..... 11

Current scaling card..... 70, 115, 324

Current sensor

- Disassembly..... 287
- Fault..... 83
- Removal..... 144, 201
- Testing..... 114

D

D1h drive..... 22

D1h–D8h

- After-repair testing..... 119

D2h drive..... 23

D2h unit..... 187

D3h drive..... 22

D4h unit..... 187

D5h drive..... 22

D6h drive..... 22

D7h unit..... 187

DC bus..... 49, 92, 107

DC bus rails..... 147, 211

DC capacitor..... 49, 81, 168, 216, 224, 297

DC capacitor

- Standard..... 156, 162, 220
- Twistlock..... 164, 168, 228

DC capacitor fastener maps..... 301

DC capacitor layouts..... 301

DC current..... 35

DC snubber capacitor..... 295

DC voltage levels..... 321

Default settings..... 33

Discharge time..... 13, 89, 91, 111, 118, 129, 186, 246, 259

Disconnect..... 13, 29, 103, 182, 242, 277

Display..... 107

Disposal..... 11

Documentation..... 9

Door fan..... 173, 235

Door filter..... 307

Drive

- Lifting..... 247
- Operation..... 42
- Testing..... 89

Dynamic testing..... 105

E

E1h unit..... 28

E1h–E4h

- After-repair testing..... 119
- Fan power card..... 97

E2h unit..... 28

Earthing..... 87

Electromagnetic compatibility (EMC)..... 254

Electromagnetic interference (EMI)..... 83

Electrostatic discharge (ESD)..... 14

Electrostatic Discharge (ESD)..... 91

EMC

- Installation..... 88

EMC shield..... 196

Extended options cabinet..... 178, 240

Extended Options Cabinet..... 180

External commands..... 37

F

Fan

- Door..... 58, 173, 235
- Door fan..... 307
- Heat sink..... 57, 170, 178, 232, 293
- Mixing..... 57, 142, 198, 279
- Operation..... 57
- Power card mixing fan..... 281
- Settings..... 58
- Speed control..... 57
- Testing..... 116
- Top..... 58, 175, 237, 309

Fan power card

- Illustration..... 97
- Installation..... 267, 268
- Overtemperature trip..... 322
- Troubleshooting..... 70
- Warning..... 79

Fans

- Warning..... 70, 77

Fault log..... 31

Feedback..... 35, 76

Fire mode..... 77

Fuse..... 29, 103, 136, 192, 277

G

Gate drive..... 152

Gate drive card..... 45, 98, 99, 112, 205, 285

Gate drive card mounting plate..... 283

Gate signal..... 83

Glossary..... 10

Ground

- Warning..... 74

Grounding..... 87

H

Hand on..... 31, 34

Heat sink

- Alarm..... 73
- Fan..... 170, 232, 293
- Overtemperature trip..... 322
- Warning..... 75, 78

Heat sink fan..... 240

Heater..... 29

High frequency card..... 146, 291

High voltage..... 72

High voltage warning..... 12

Horizontal brake busbars..... 313

I	
IGBT	
Gate drive card.....	152, 205, 285
Gate drive signals.....	112
Gate resistor test.....	103
Motor problem cause.....	83
Removal.....	154, 214, 305
Switching.....	111
Temperature sensor test.....	102
IGBT module.....	305
Impedance.....	82
Indicator lights.....	31
Initialization.....	33
Input	
Digital.....	36, 37, 38
Imbalance.....	108
Signal.....	82
Terminal.....	194
Voltage.....	107
Input plate.....	275, 277
Inrush card.....	148, 207, 269, 322
Inrush card frame.....	271
Installation	
Qualified personnel.....	12
Intermediate section.....	49, 102
Internal fault.....	73
Inverter	
Function.....	52
Testing.....	101
J	
J8 drive.....	22
L	
Label.....	16
Leakage current.....	13
LED.....	31, 66, 129, 186, 246, 259
Lifting.....	14, 247
Load share	
Overview.....	58
Warning.....	12, 72
Load share.....	13, 318
Local control.....	30, 34
Local control panel (LCP).....	30, 44, 107
Logic section.....	44
M	
Main Menu.....	31
Main Menu Mode.....	32
Mains	
Shield.....	14
Voltage.....	35
Warning.....	73
Manual initialization.....	33
Manuals.....	9
MDCIC.....	25, 52, 93
Menu keys.....	31
Menu structure.....	31
Microprocessor.....	44
Mixing fan.....	142, 198, 279, 281
Motor	
Load.....	82
Overheating.....	69
Parameters.....	80
Terminal block.....	197
Unintended motor rotation.....	13
Warning.....	68, 69, 71
Multi-drive control interface card (MDCIC).....	25, 52, 93, 96
N	
Nameplate.....	16
Navigation keys.....	31, 34
O	
Options	
Brake.....	55
Load share.....	318
Regen.....	318
Options cabinet.....	29, 180, 240
Output	
Contactor.....	88
Current.....	35
Parameters.....	82
Voltage.....	81, 119
Overcurrent.....	36, 69
Overtemperature.....	83
Overvoltage.....	36, 81
P	
Parallel drive module	
Block diagram.....	358
Components.....	256
Current scaling card.....	324
Illustration.....	26, 27
Installation.....	251
Programming.....	125
Reinstallation.....	125
Removal.....	250
Service kit troubleshooting.....	125
Testing.....	124

Parallel drive system		Replacement Parts.....	323
After-repair testing.....	119	Reset.....	30, 31, 33, 37, 69, 75
Block diagram.....	359, 360	RFI filter.....	136, 192, 277
Illustration.....	24	RFI Filter.....	29
Testing.....	92	Rotor	
Parameter		Warning.....	77
Default.....	33	Run permissive.....	35
Menus.....	31		
Settings.....	33	S	
Set-up.....	32	Safe Torque Off	
Part Numbers.....	323	Warning.....	75
Phase loss.....	68, 81, 82	Safety.....	12, 129, 186, 246, 259
Pin outs.....	126	SCR/diode modules.....	273
Power card		SCRs.....	100, 109, 150, 209
Connections.....	59	Serial communication.....	31, 34, 35, 36, 37
D-sized drive.....	94	Serial number.....	15
E-sized drive.....	95	Service report.....	15
Function.....	44	Setpoint.....	36
Illustration.....	134, 190	Set-up.....	31
Installation.....	265	Shielding	
Mounting plate.....	132, 190, 263	Mains.....	14
Overtemperature trip.....	322	Short circuit.....	70
Removal.....	190	Signal test board.....	125, 126
Warning.....	75	Sleep mode.....	36
Power components.....	45	Spare Parts.....	323
Power rating.....	16	Speed reference.....	34
Power terminal		Split bus power supply.....	120, 122
D-sized drives.....	105	Start up.....	33
E-sized drives.....	106	Static tests.....	100
Power terminal mounting plate.....	141, 200	Status mode.....	34
Programming.....	30, 31, 33, 82	Stop command.....	36
PWM waveforms.....	44	Switch mode power supply (SMPS).....	108
		Switching frequency.....	36
Q			
Q1 My Personal Menu.....	32	T	
Q2 Quick Setup.....	32	Terminal	
Qualified personnel.....	12	Brake.....	141, 196
Quick Menu.....	31, 32	Control.....	34, 37, 44, 82
		Input.....	117
R		Mains.....	138
Ratings.....	16, 17, 18	Motor.....	140, 197
Rectifier		Power.....	105, 106, 200
Bus plate.....	271	Regen.....	59
Function.....	46		
Testing.....	100		
Recycling.....	11		
Reference.....	34, 35, 36		
Regen			
Illustration.....	318		
Load sharing.....	58		
Terminal.....	59		
Relays.....	44		
Remote reference.....	35		

Testing		Website.....	9
Brake IGBT.....	101	Windmilling.....	13
Circuit breaker.....	104	Wiring.....	14, 87
Connection points.....	92		
Contactor.....	104		
Control card.....	107		
Current sensor.....	114		
DC bus.....	107		
Disconnect.....	103		
Display.....	107		
Dynamic.....	105		
ESD precaution.....	91		
Fan.....	116		
Fuses.....	103		
IGBT.....	111		
Input imbalance.....	108		
Input terminal.....	117		
Input voltage.....	107		
Instruments.....	15, 90		
Intermediate section.....	102		
Inverter.....	101		
Parallel drive system.....	92		
Rectifier circuits.....	100		
SCRs.....	109		
Signal test board.....	90		
Static tests.....	100		
Thermistor			
Warning.....	75		
Top fan.....	175, 237, 309		
Torque			
Limit.....	69, 83		
Parameters.....	80		
Values.....	319		
Troubleshooting			
Codes.....	66		
Display.....	62		
Motor operation.....	62		
Symptoms.....	60		
Tips.....	60		
Warnings and alarms.....	68		
Type approvals.....	11		
Type code.....	16, 124		
U			
Unintended start.....	12		
V			
Vertical brake busbars.....	311		
Voltage			
Imbalance.....	68		
Rating.....	17, 18, 19, 20, 21		
W			
Warnings			
Codes.....	66		
List of.....	68		
Trip points.....	321, 322		
Waveform.....	81		



.....
Danfoss can accept no responsibility for possible errors in catalogues, brochures and other printed material. Danfoss reserves the right to alter its products without notice. This also applies to products already on order provided that such alterations can be made without subsequential changes being necessary in specifications already agreed. All trademarks in this material are property of the respective companies. Danfoss and the Danfoss logotype are trademarks of Danfoss A/S. All rights reserved.
.....

Danfoss A/S
Ulsnaes 1
DK-6300 Graasten
vlt-drives.danfoss.com

