



KIT SUCTION FLANGE

100151, 100151-1, 100402, & 100402-1.



Installation and servicing of Danfoss Turbocor® compressors by qualified and product trained personnel only. Follow these instructions and sound refrigeration/electrical/servicing practices relating to installation, commissioning, maintenance and service.

<p>Consult the appropriate Danfoss Turbocor Compressors Inc. (DTC) Service Manual on turbocor.danfoss.com for detailed service instructions.</p>	<p>Never power compressor without covers in place and secured.</p> <p>Removing the mains input cover will expose you to a voltage hazard of up to 575V. Ensure the mains input power is off and locked out before removing cover.</p> <p>Before removing top cover, wait at least 20 minutes after isolating AC power to allow the high voltage capacitors to discharge.</p>	<p>Always wear appropriately rated safety equipment when working around equipment and/or components energized with high voltage.</p> <p>This equipment contains hazardous voltages that can cause serious injury or death.</p>	<p>Recover all refrigerant from compressor in accordance with local codes and ensure pressure is fully vented before the removal of refrigerant containing components.</p>
--	---	---	---

1 - Introduction:

SUCTION FLANGE replacement.

This kit contains the Suction Flange, O-ring, and associated hardware.

We have made the **TTS/TGS/TTH/TGH Service Manual** available to anyone. To access the manual, you may scan the applicable QR code below or you may go to our DTC website at www.turbocoroem.com. At the top of the page there is a pull-down menu called "Quick Links." Click this menu and select the appropriate service manual.

Refer to the applicable QR code below to download the TTS/TGS/TTH/TGH Service Manual.

English



Chinese



2 - Removal and Installation Instructions:

1. Isolate compressor power.
2. Isolate the compressor and recover the refrigerant according to industry standards.
1. Remove the blind flange and align suction pipe and flange.
2. Complete the flange welding or brazing process.
3. Clean the O-ring groove and mating surface with a lint-free cloth.
4. Apply lube on the new O-ring.
5. Insert the new O-ring onto the O-ring groove on the main housing.
6. Assemble the four sets of new M16 x 45 hex head screws and lock washers.
7. Align the suction valve/flange with the compressor suction port (see Figure 1) and insert the four hex head screws. Finger-tighten the screws and then torque, in a diagonal pattern, to 30 Nm (22.1 ft.lb.).
8. Torque the screws a final time to 75 Nm (55 ft. lb.).
9. Leak test and evacuate compressor in accordance with standard industry practices.
10. Return the compressor to normal operation.

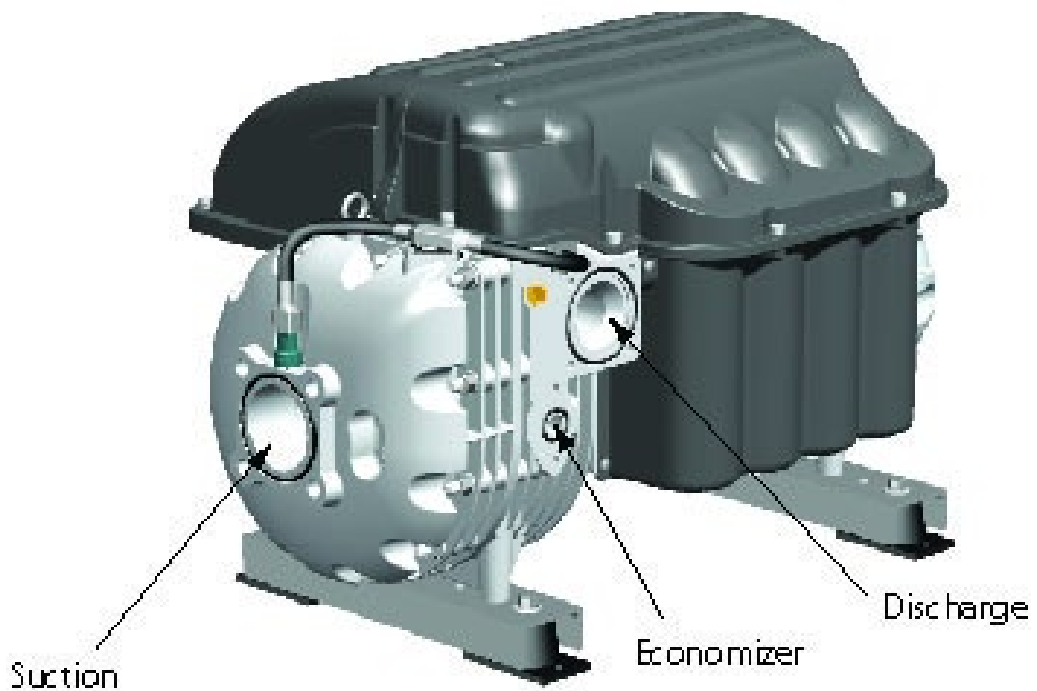







Figure 1

Kit Contents

QTY	Part(s) Description	Picture(s)
1	SUCTION FLANGE FOR 3" PIPE	
4	WASHER M16 SPLIT LOCK	

4	SCREW M16x45 HEX HEAD CAP	
1	O-RING	
1	LUBRICATION-SUPER-O-LUBE-2G	

Danfoss can accept no responsibility for possible errors in catalogues, brochures, and other printed material. Danfoss reserves the right to alter its products without notice. This also applies to products already on order provided that such alterations can be made without subsequential changes being necessary in specifications already agreed. All trademarks in this material are property of the respective companies. Danfoss and the Danfoss logotype are trademarks of Danfoss A/S. All rights reserved.