

Bulletin | Danfoss Turbocor Compressors

# Customer Notification

B-CN-175-EN REV A

7/11/2019

**SUBJECT:** TTH and TGH High Lift Compressor Product Release

## Purpose

This is to inform our customers that the new **TTH/TGH High Lift Series Turbocor®** compressors have been widely released and are available for order.



Two (2) models are available: TTH375 with a nominal capacity of 107 tons / 376 kW and TGH285 with a nominal capacity of 82 tons / 288 kW at typical air-cooled conditions. The TTH and TGH compressors provide a high-efficiency solution that enables an oil-free air-cooled chiller solution that can be deployed as a global platform.

## Summary

The new TTH/TGH Compressors are now available for ordering by Turbocor® OEMs. The standard lead time for these new compressors is eight (8) weeks initially.

Danfoss Turbocor® Technical Publications have been updated to include the new TTH and TGH Series compressors and can be found on our website ([www.turbocoroem.com](http://www.turbocoroem.com)).

There are some new spare part kits that have been created which are specific to the TTH and TGH Series compressors. These have been included in the latest Spare Parts Manual.

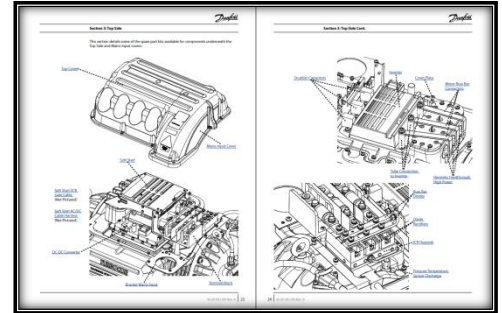

## TTH/TGH Compressor Configuration

The TTH and TGH Series compressors will be configured as a major revision "F" compressor and will come with 4.2.0 firmware. With the release of TTH/TGH, these compressors will now be available by using our new Variant Configuration system available on [dtconfig.danfoss.com](http://dtconfig.danfoss.com). Customers no longer need to use dedicated compressor part numbers for new models. Customers can place orders using the full compressor Type Code. New stock keeping unit (SKU) numbers will be of the type 199BXXXX and will be generated at the time of order or can be requested from your Key Account Manager.

The TTH and TGH series compressors will use the new compressor Type Code that was published in Bulletin B-CN-164-EN Nomenclature Update & Variant Configuration. This type code will appear in the description on all nameplates, labels, boxes, and documentation.

TTH375FES2S010X0XX **S350**

↑ 4.2.0 Software Option

### Software (character 19-22)

S350 : DTC SW 4.2.0 TTH/TGH

## Action Required

---

Customers wishing to purchase the new TTH and TGH Series compressors can contact their Key Account Manager to determine pricing. Customers should visit [dtconfig.danfoss.com](http://dtconfig.danfoss.com) to configure their compressor according to their specifications. With compressor pricing and Type Code defined, customers can place an order with Danfoss Customer Service at [turbocor.cs.na@danfoss.com](mailto:turbocor.cs.na@danfoss.com).

A separate bulletin will be distributed for 4.2.0 firmware containing compressor configuration options and spare part BMCC part numbers.

As a result of the TTH/TGH product launch, many of the manuals and guides provided by DTC have been modified. These include:

- M-AP-001-EN Applications and Installation Manual Rev P
- M-PR-001-EN TT/TG Programming Manual Rev J.1
- M-SV-001-EN TTS/TGS/TTH/TGH Service Manual Rev F.1
- M-SM-001-EN TT/TG Service Monitoring Tools User Manual Rev G
- M-SP-001-EN TT and TG Spare Parts Manual Rev E.1

Please reference these new manuals going forward for all TT(S)/TG(S)/TTH/TGH compressors.

## Need Assistance

---

For more information please contact your Key Account Manager or our Product Support group at [turbocor.ps.na@danfoss.com](mailto:turbocor.ps.na@danfoss.com) or [eu.support@danfoss.com](mailto:eu.support@danfoss.com) for inquiries within Europe.