



KIT HERMETIC FEEDTHROUGH - HIGH POWER

100383, 100383-1



Installation and servicing of Danfoss Turbocor® compressors by qualified and product trained personnel only. Follow these instructions and sound refrigeration/electrical/servicing practices relating to installation, commissioning, maintenance and service.

<p>Consult the appropriate Danfoss Turbocor Compressors Inc. (DTC) Service Manual on turbocor.danfoss.com for detailed service instructions.</p>	<p>Never power compressor without covers in place and secured.</p> <p>Removing the mains input cover will expose you to a voltage hazard of up to 575V. Ensure the mains input power is off and locked out before removing cover.</p> <p>Before removing top cover, wait at least 20 minutes after isolating AC power to allow the high voltage capacitors to discharge.</p>	<p>Always wear appropriately rated safety equipment when working around equipment and/or components energized with high voltage.</p> <p>This equipment contains hazardous voltages that can cause serious injury or death.</p>	<p>Recover all refrigerant from compressor in accordance with local codes and ensure pressure is fully vented before the removal of refrigerant containing components.</p>
--	---	---	---

1 - Introduction:

HERMETIC FEEDTHROUGH - HIGH POWER replacement.

This kit contains the High Power Feedthroughs. Please refer to our Service Manual for details regarding the replacement of the feedthroughs.

We have made the **TTS/TGS/TTH/TGH Service Manual** available to anyone. To access the manual, you may scan the applicable QR code below or you may go to our DTC website at www.turbocoroem.com. At the top of the page there is a pull-down menu called "Quick Links." Click this menu and select the appropriate service manual.

Refer to the applicable QR code below to download the TTS/TGS/TTH/TGH Service Manual.

English



Chinese



2 - HERMETIC FEEDTHROUGH - HIGH POWER Removal Instructions:

1. Isolate compressor power as described in Section "Electrical Isolation of the Compressor" of the Service Manual (M-SV-001).
2. Isolate the compressor and recover the refrigerant according to industry standards.
3. Remove the top covers.

4. Disconnect the two (2) connectors from the Thermistor Sensor Feedthroughs.
5. Remove the Motor Bus Bars.
6. Remove the Motor Cover Plate.
7. Remove the High-Power Feedthroughs.

WARNING: While loosening the High-Power Feedthrough Nuts, it is important to hold the inner nut with a wrench. Failure to do so could place an excessive load on the feedthrough causing internal damage.

8. Remove the three (3) High-Power Feedthrough O-rings from the Main Housing if they did not come out with the old feedthroughs.
9. Inspect the sealing area for any residue or debris and clean the threads with a lint-free cloth if needed.

3 - HERMETIC FEEDTHROUGH - HIGH POWER Installation Instructions:

1. Inspect, lubricate, and install the new O-rings onto the new High-Power Feedthroughs.
2. Thread one (1) nut onto the inner side of each of the three (3) High-Power Feedthroughs. Thread each nut by hand until it is seated against the feedthrough, then back off the nut at least one (1) full revolution. Do not torque the inner High-Power Feedthrough Nuts. Refer to Figure 8 (Inner Nut Installation).
3. Thread each High-Power Feedthrough halfway into the Main Housing.
4. Slide the Motor Leads onto the High-Power Feedthroughs.
5. Continue to thread the High-Power Feedthroughs into the housing by hand until they stop. Torque to 22 Nm (16 ft.lb.).
6. Position the Motor Leads against the inner High-Power Feedthrough Nuts, then install the lock washers and outer High-Power Feedthrough Nuts.

Warning: Be sure that once the inner nut is seated against the feedthrough, it is backed out at least one revolution. Otherwise damage to the feedthrough could occur.

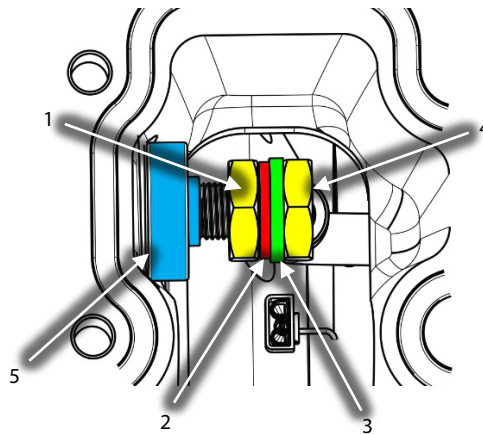

Figure 1 – Inner Nut Installation

No.	Component
1	Inside Nut (not torqued)
2	Motor Lead
3	Lock Washer
4	Outer Nut
5	Feedthrough

7. Once the nuts are finger tight, hold the inner nut with a wrench and torque the outer nut to 15.5 Nm (11.5 ft.lb.).

WARNING: While torquing the High-Power Feedthrough Nuts, it is important to hold the inner nut with a wrench. Failure to do so could place an excessive load on the feedthrough causing internal damage. Also, the feedthrough itself could move which could allow it to loosen or be over torqued.

8. Clean the Main Housing and Cover Plate mating surface with a lint-free cloth. Inspect the sealing area for any damage.
9. Install the O-Ring into the groove of the main housing. Assembly must be made with care so that the O-Ring is properly placed in the groove and not damaged as the housing is closed.
10. Install the Motor Cover Plate.
11. Connect the two (2) connectors onto the Thermistor Sensor Feedthroughs.
12. Thread one (1) nut onto the outer side of each of the three (3) High-Power Feedthroughs. Thread each nut by hand until it is seated against the feedthrough, then back off the nut at least one (1) full revolution. Do not torque the inner High-Power Feedthrough Nuts. Refer to Figure 10 (Outer Nut Installation).
13. Slide the bus bar over the new High-Power Feedthrough until it makes contact with the inner nut.
14. Install the three (3) Bus Bar to Inverter fasteners through the copper tubes. Initially thread the fasteners into the Inverter by hand. Torque to 14 Nm (10 ft.lb.).
15. Back out the three (3) inner High-Power Feedthrough Nuts until they rest against the Bus Bars.
Warning: Be sure that once the inner nut is seated against the feedthrough, it is backed out at least one revolution. Otherwise damage to the feedthrough could occur.

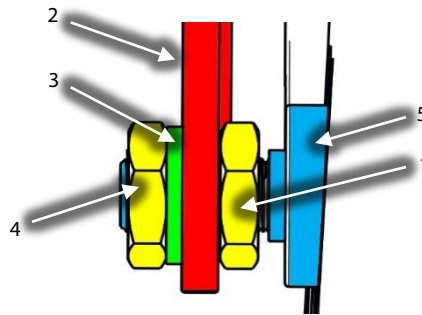

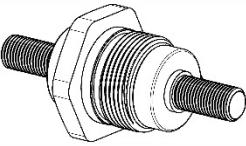
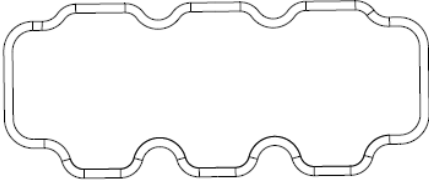





Figure 2 – Outer Nut Installation

No.	Component
1	Inside Nut (not torqued)
2	Motor Bus Bar
3	Lock Washer
4	Outer Nut
5	Feedthrough

16. Install the outer three (3) High-Power Feedthrough Nuts and lock washers, and torque to 15.5 Nm (11.5 ft.lb.)
17. Install the Soft Start.
18. Install the top covers.
19. Leak test and evacuate compressor in accordance with standard industry practices.
20. Return the compressor to normal operation.

4 - Kit Contents:

QTY	Part(s) Description	Picture(s)

3	FEEDTHROUGH - HIGH POWER- ASSEMBLY (requires 36mm socket)	
1	O-RING (COVER PLATE)	
3	O-RING	
6	WASHER, M10, SPLIT LOCK	
12	NUT BRASS M10 X 1 X 5MM THICK (requires 17mm socket/wrench)	
10	SCREW M8X25 SOCKET HEAD CAP	
1	LUBRICATION-SUPER-O-LUBE-2G	

Danfoss can accept no responsibility for possible errors in catalogues, brochures and other printed material. Danfoss reserves the right to alter its products without notice. This also applies to products already on order provided that such alterations can be made without subsequential changes being necessary in specifications already agreed. All trademarks in this material are property of the respective companies. Danfoss and the Danfoss logotype are trademarks of Danfoss A/S. All rights reserved.