

SCR COOLING MANIFOLD

100309-7, -8, -9, -10, -13, -14, & -15



Installation and servicing of Danfoss Turbocor® compressors by qualified and product trained personnel only. Follow these instructions and sound refrigeration/electrical/servicing practices relating to installation, commissioning, maintenance, and service.

<p>Consult the appropriate Danfoss LLC Service Manual on www.turbocoroem.com for detailed service instructions.</p>	<p>Never power compressor without covers in place and secured.</p> <p>Removing the mains input cover will expose you to a voltage hazard of up to 575V. Ensure the mains input power is off and locked out before removing cover.</p> <p>Before removing top cover, wait at least 20 minutes after isolating AC power to allow the high voltage capacitors to discharge.</p>	<p>Always wear appropriately rated safety equipment when working around equipment and/or components energized with high voltage.</p> <p>This equipment contains hazardous voltages that can cause serious injury or death.</p>	<p>Recover all refrigerant from compressor in accordance with local codes and ensure pressure is fully vented before the removal of refrigerant containing components.</p>
--	---	---	---

1 - Introduction

SCR COOLING MANIFOLD replacement.

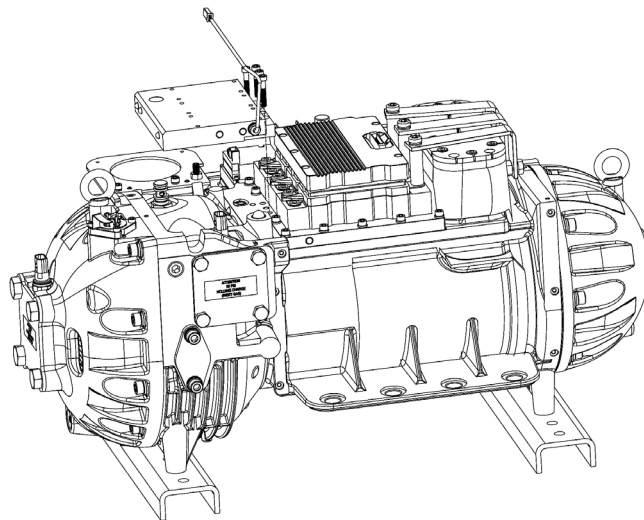

Figure 1 – SCR Cooling Manifold Example



This kit contains the SCR Cooling Manifold as well as the required O-rings and fasteners.

These instructions contain the basic steps regarding the replacement of the SCR Cooling Manifold and included O-rings and only address the major steps (they do not address any removal and installation of wiring harnesses). It is highly recommended to also reference the instructions in our Service Manual when replacing the SCR Cooling Manifold. The Service Manual will include all of the details, including when to remove wire harnesses and the torque specifications for the replacement fasteners.

We have made the **TT Series Service Manual** available to anyone. To access the manual, you may scan the applicable QR code below or you may go to our website at www.turbocoroem.com. At the bottom of the page there is a Section named "Categories" that includes various menus including one for Manuals.

Refer to the applicable QR code below to download the TT Series Service Manual.

English



Chinese



2 - Electrical Isolation

Before servicing the Compressor, isolate the compressor power by completing the following steps:

... DANGER! ...

- This equipment contains hazardous voltages that can cause serious injury or death. Only qualified and trained personnel should work on Danfoss LLC equipment.
- Always wear appropriately-rated safety equipment when working around equipment and/or components energized with high voltage.
- Removing the Mains Input Cover will expose the technician to a high voltage hazard of up to 632 VAC. Ensure the Mains Input power is turned off and locked out before removing the Mains Input Cover.

1. Turn off the Mains Input power to the compressor.
2. Lock Out/Tag Out (LOTO) the mains disconnect to ensure no accidental or unauthorized reapplication of the Mains Input power can occur.

NOTE

The Mains Input fast-acting fuses are installed in the power panel for all compressor models except the TTS300/TGS230.

3. Remove the Mains Input Cover only.
4. Using an appropriately-rated voltage meter, confirm the absence of AC voltage.

... DANGER! ...

Do not touch any components when removing the Mains Input Cover.

5. If AC voltage is not present, reinstall the Mains Input cover and wait at least 20 minutes before removing either the Mains Input or Top Side Cover. If AC voltage still exists, go back to Step 2 to determine why the compressor voltage is not isolated.
6. Remove the Top Cover, taking particular care not to touch ANY components underneath. Refer to Section 1.1.2 Top Cover on page 1.

- Using an appropriately-rated voltage meter, check the DC Bus Bars for DC voltage level. If the voltage is above 30 volts direct current (VDC), wait five (5) minutes and recheck until voltage is below 30 VDC. Refer to **Figure 2 - DC Bus Voltage Test Points**.

... CAUTION ...

Even at low voltages, caution should be used around the capacitors to avoid quick discharge events, which can lead to reduced reliability.

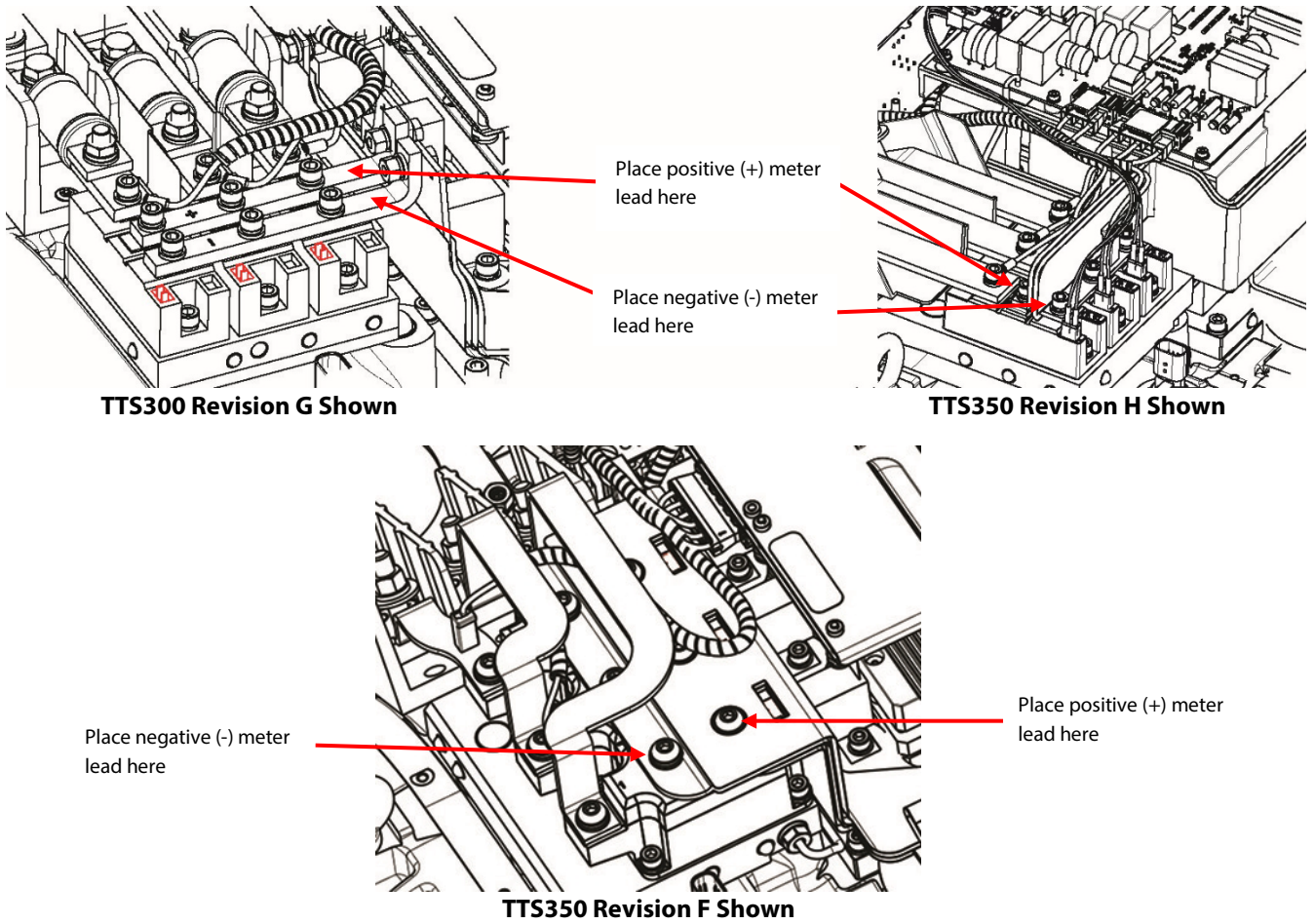

Figure 2 - DC Bus Voltage Test Points

3 - High SST Option – Kit 100309-8

This kit can be used to provide a high SST option for the following Revision H Turbocor compressors:

- TTS350 & TGS310
- TTS450 & TGS380
- TTS400 & TGS390
- TTS700 & TGS520
- TGS490
- TTH375 & TGH285

To convert to the High SST option, new snubber capacitors and a BMCC with software (4.3.0 or later) will need to be added (if not already equipped). These items are not included in this kit; therefore, they must be purchased separately.

In the table below, the two (2) different style snubber capacitors are shown for comparison.

If you are converting to High SST, refer to Section 6 below.

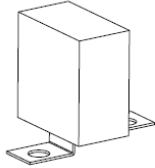
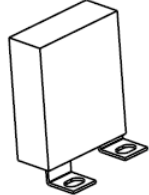
Required for High SST Upgrade	Not for Use on High SST Compressors
	
Kit 100417 – This style required for High SST Option	Snubber capacitors installed on standard temperature compressors.

4 - SCR Cooling Manifold Removal Instructions (Excluding TTS300/TGS230 Compressors)

NOTE: Kits 100309-13 and 100309-14 do not include the SCR Temperature Sensor as these sensors are no longer required. After installing the new SCR Cooling Manifold, secure the remaining connector on the compressor with a cable tie.

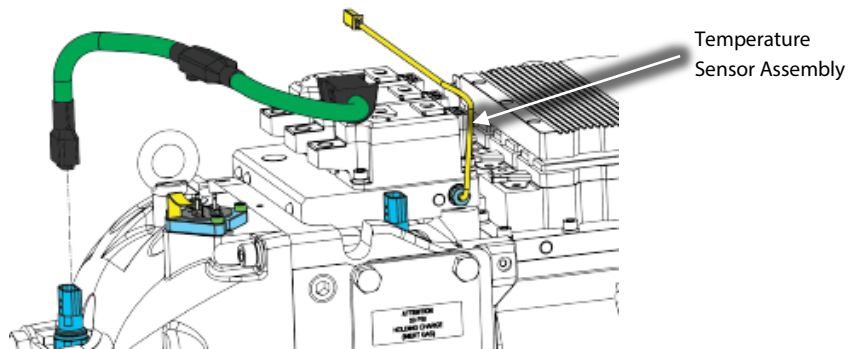

Figure 3 – Temperature Sensor

1. Isolate compressor power as described in the “Electrical Isolation” section above prior to performing any service procedures.
2. Isolate the compressor and recover the refrigerant according to industry standards.
3. Remove the Soft Start.
4. Remove the Terminal Block assembly.
5. Remove the DC Capacitor Bus Bar Assembly.
6. Carefully remove the SCR Cooling Manifold from the Compressor. Refer to *Figure 4 – SCR Cooling Manifold Removal* for this and the following removal steps.

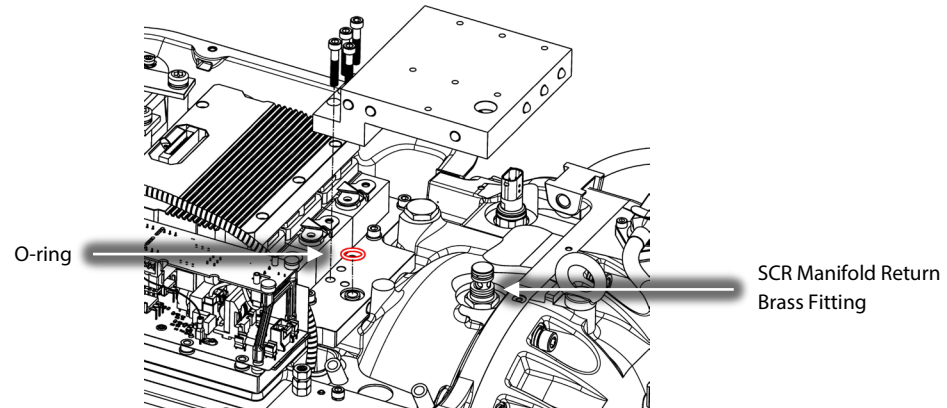

Figure 4 – SCR Cooling Manifold Removal

7. If converting to High SST, continue to Section 6.

NOTE: If either the SCR Manifold Return Brass fitting or the Brass Plug is suspected of leaking at the housing connection, and you have a Revision H or later compressor, replace the leaking O-ring. These O-rings are currently only included in kit 100309-8. If you have purchased this kit, refer to Section 6 for the details of the O-ring replacement.

5 - SCR Cooling Manifold Installation Instructions (Excluding TTS300/TGS230 Compressors)

1. Install new O-rings onto the SCR Manifold Return Brass Fitting and Inverter Heat Sink Plate.
2. Carefully install the SCR Cooling Manifold over the SCR Manifold Return Brass Fitting.
3. Leak test and evacuate compressor in accordance with standard industry practices.
4. Install the DC Capacitor Bus Bar Assembly.
5. Install the Terminal Block assembly.
6. Install the Soft Start.
7. Install the top covers.
8. Return the compressor to normal operation.

6 - High SST Upgrade – Kit 100309-8: (Upgrade to High SST Only)

If you are converting the compressor to our High SST option, the locations of the SCR Manifold Return Brass Fitting and the Brass Plug must be swapped. Refer to the required steps below.

NOTE: This only applies to Major Revision H Compressors and later and cannot be applied to prior revisions.

1. Follow the instructions in Sections 4 and 5 above regarding the removal and installation of the SCR Cooling Manifold.
2. Remove the SCR Manifold Return Brass Fitting. Refer to *Figure 5 – Plug and SCR Manifold Return Brass Fitting Locations*.
3. Remove the Brass Plug. Refer to *Figure 5 – Plug and SCR Manifold Return Brass Fitting Locations*.
4. Remove and discard the lower O-ring from the SCR Manifold Return Brass Fitting.
5. Remove the O-ring from the Brass Plug. Refer to *Figure 5 – Plug and SCR Manifold Return Brass Fitting Locations*.

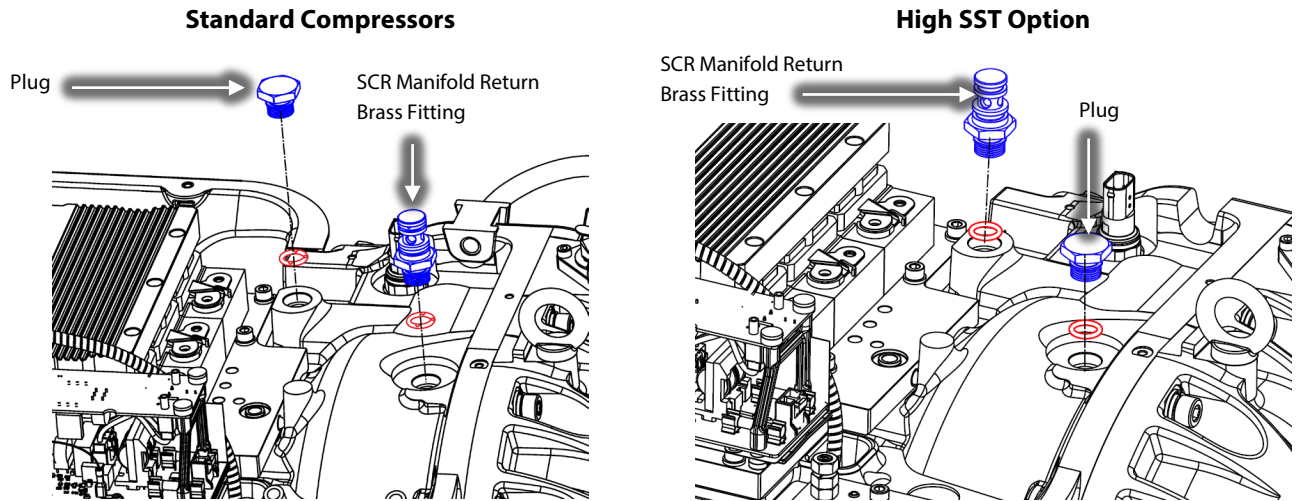

Figure 5 – Plug and SCR Manifold Return Brass Fitting Locations

6. Clean the lower O-ring grooves in the Plug and SCR Manifold Return Brass Fitting. Refer to *Figure 6 – O-Ring Grooves*.
7. Ensure the threads and surface area in the compressor housing are clean.

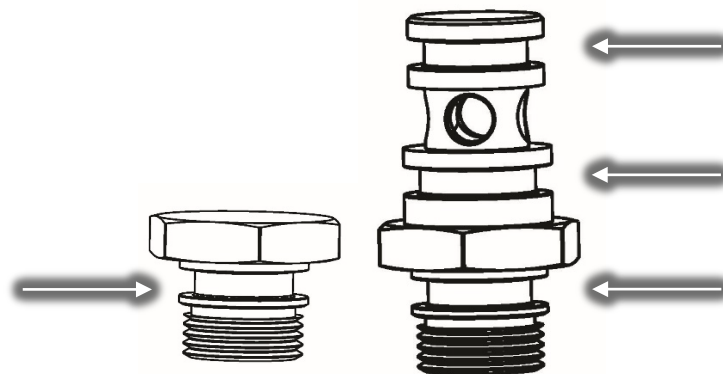

Figure 6 – O-Ring Grooves

8. Apply O-lube to the new lower O-ring for the SCR Manifold Return Brass Fitting and install it onto the fitting.





NOTE: The bottom two O-rings on the SCR Manifold Return Fitting are larger than the top O-ring.



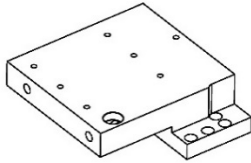

9. Install the SCR Manifold Return Brass Fitting into the compressor housing (where the Brass Plug was previously installed) and torque to 7 Nm (62 in.lb). Refer to *Figure 5 – Plug and SCR Manifold Return Brass Fitting Locations*.
10. Apply O-lube to the new O-ring for the Brass Plug and install it onto the fitting.
11. Install the Brass Plug (where the SCR Manifold Return Brass Fitting was previously installed) and torque to 7 Nm (62 in.lb). Refer to *Figure 5 – Plug and SCR Manifold Return Brass Fitting Locations*.
12. Return to the above SCR Cooling Manifold steps for the remainder of the installation.

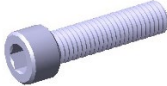

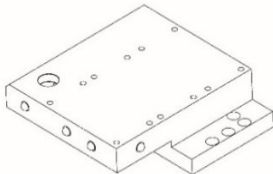

NOTE: The High SST option will require new snubber capacitors and a BMCC with software (4.3.0 or later) if not already equipped. Please order those components as needed and follow the included installation instructions.

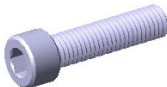

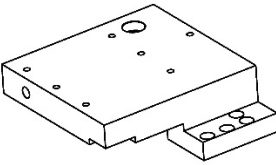

7 - Kit Contents

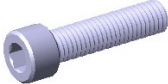

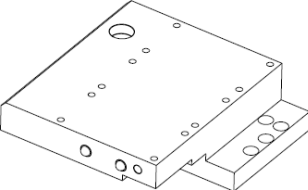

Note: Any part numbers included in the kit contents are internal part numbers only. Please refer to our Spare Parts Manuals for any kit part numbers.

KIT	100309-8	
QTY	Part(s) Description	Picture(s)
1	SCR HEATSINK ASSEMBLY	
3	O-RING, SCR COOLING ADAPTER - 901862	
2	O-RING, SCR COOLING ADAPTER - 901850	
4	SCREW M6X35, SOCKET HEAD CAP - 902821	
1	LUBRICATION-SUPER-O-LUBE-2G	

KIT	100309-7	
QTY	Part(s) Description	Picture(s)
1	SCR HEATSINK ASSEMBLY	
1	O-RING, SCR COOLING ADAPTER - 901862	
2	O-RING, SCR COOLING ADAPTER - 901850	
4	SCREW M6X35, SOCKET HEAD CAP - 902821	
1	LUBRICATION-SUPER-O-LUBE-2G	

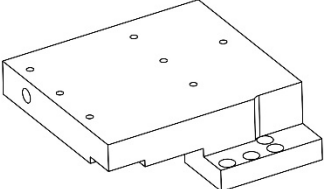
KIT	100309-9, 10	
QTY	Part(s) Description	Picture(s)
1	SCR HEATSINK ASSEMBLY	
1	O-RING, SCR COOLING ADAPTER - 901862	
2	O-RING, SCR COOLING ADAPTER - 901850	
4	SCREW, M6X35, SOCKET HEAD CAP - 902821	
1	LUBRICATION-SUPER-O-LUBE-2G	

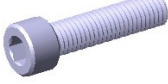
KIT	100309-13, 14	
QTY	Part(s) Description	Picture(s)
1	SCR HEATSINK ASSEMBLY	
1	O-RING, SCR COOLING ADAPTER - 901862	
2	O-RING, SCR COOLING ADAPTER - 901850	
4	SCREW, M6X35, SOCKET HEAD CAP - 902821	
1	LUBRICATION-SUPER-O-LUBE-2G	

KIT	100309-15	
QTY	Part(s) Description	Picture(s)
1	SCR HEATSINK ASSEMBLY	
2	O-RING, SCR COOLING ADAPTER - 901850	
4	SCREW, M6X35, SOCKET HEAD CAP - 902821	
1	LUBRICATION-SUPER-O-LUBE-2G	



8 - List of Changes

Revision	Date	Description of Change
S	4/11/2023	The kit obsolete kit numbers (100309-1, 100309-5) were removed from the top of this instruction and in the BOM list above. The removal and replacement steps were completely revised.
T	5/15/2023	Added kit 100309-15.

Danfoss LLC can accept no responsibility for possible errors in catalogues, brochures, and other printed material. Danfoss reserves the right to alter its products without notice. This also applies to products already on order provided that such alterations can be made without subsequential changes being necessary in specifications already agreed. All trademarks in this material are property of the respective companies. Danfoss and the Danfoss logotype are trademarks of Danfoss A/S. All rights reserved.