

RELIEF MEMBRANE

100122



Installation and servicing of Danfoss Turbocor® compressors by qualified and product trained personnel only. Follow these instructions and sound refrigeration/electrical/servicing practices relating to installation, commissioning, maintenance, and service.

<p>Consult the appropriate Danfoss Turbocor Compressors Inc. (DTC) Service Manual on turbocoroem.com for detailed service instructions.</p>	<p>Never power compressor without covers in place and secured.</p> <p>Removing the mains input cover will expose you to a voltage hazard of up to 575V. Ensure the mains input power is off and locked out before removing cover.</p> <p>Before removing top cover, wait at least 20 minutes after isolating AC power to allow the high voltage capacitors to discharge.</p>	<p>Always wear appropriately rated safety equipment when working around equipment and/or components energized with high voltage.</p> <p>This equipment contains hazardous voltages that can cause serious injury or death.</p>	<p>Recover all refrigerant from compressor in accordance with local codes and ensure pressure is fully vented before the removal of refrigerant containing components.</p>
--	---	---	---

1 - Introduction

RELIEF MEMBRANE replacement.

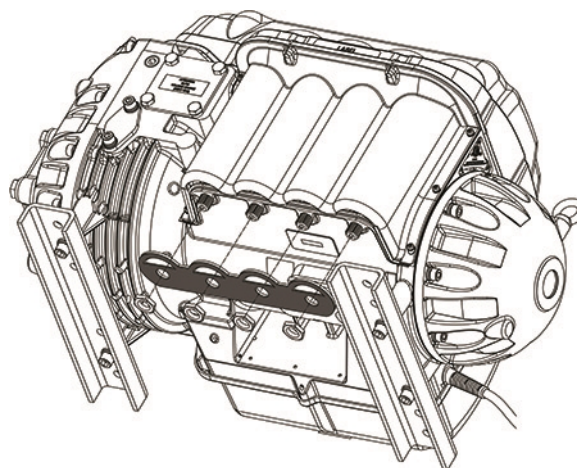

Figure 1 – Relief Membrane



Please refer to our Service Manual for further details regarding the replacement of the Relief Membrane.

We have made the **TT Series Service Manual** available to anyone. To access the manual, you may scan the applicable QR code below or you may go to our DTC website at www.turbocoroem.com. At the bottom of the page there is a Section named "Categories" that includes various menus including one for Manuals.

Refer to the applicable QR code below to download the TT Series Service Manual.

English



Chinese



2 - Electrical Isolation

Before servicing the Compressor, isolate the compressor power by completing the following steps:

... DANGER! ...

- This equipment contains hazardous voltages that can cause serious injury or death. Only qualified and trained personnel should work on Danfoss LLC equipment.
- Always wear appropriately-rated safety equipment when working around equipment and/or components energized with high voltage.
- Removing the Mains Input Cover will expose the technician to a high voltage hazard of up to 632 VAC. Ensure the Mains Input power is turned off and locked out before removing the Mains Input Cover.

1. Turn off the Mains Input power to the compressor.
2. Lock Out/Tag Out (LOTO) the mains disconnect to ensure no accidental or unauthorized reapplication of the Mains Input power can occur.

NOTE

The Mains Input fast-acting fuses are installed in the power panel for all compressor models except the TTS300/TGS230.

3. Remove the Mains Cover only.
4. Using an appropriately-rated voltage meter, confirm the absence of AC voltage.

... DANGER! ...

Do not touch any components when removing the Mains Input Cover.

5. If AC voltage is not present, reinstall the Mains Input cover and wait at least 20 minutes before removing either the Mains Input or Top Side Cover. If AC voltage still exists, go back to Step 2 to determine why the compressor voltage is not isolated.
6. Remove the Top Cover, taking particular care not to touch ANY components underneath. Refer to Section 1.1.2 Top Cover on page 1.
7. Using an appropriately-rated voltage meter, check the DC Bus Bars for DC voltage level. If the voltage is above 30 volts direct current (VDC), wait five (5) minutes and recheck until voltage is below 30 VDC. Refer to Figure 1 - DC Bus Voltage Test Points.

... CAUTION ...

Even at low voltages, caution should be used around the capacitors to avoid quick discharge events, which can lead to reduced reliability.

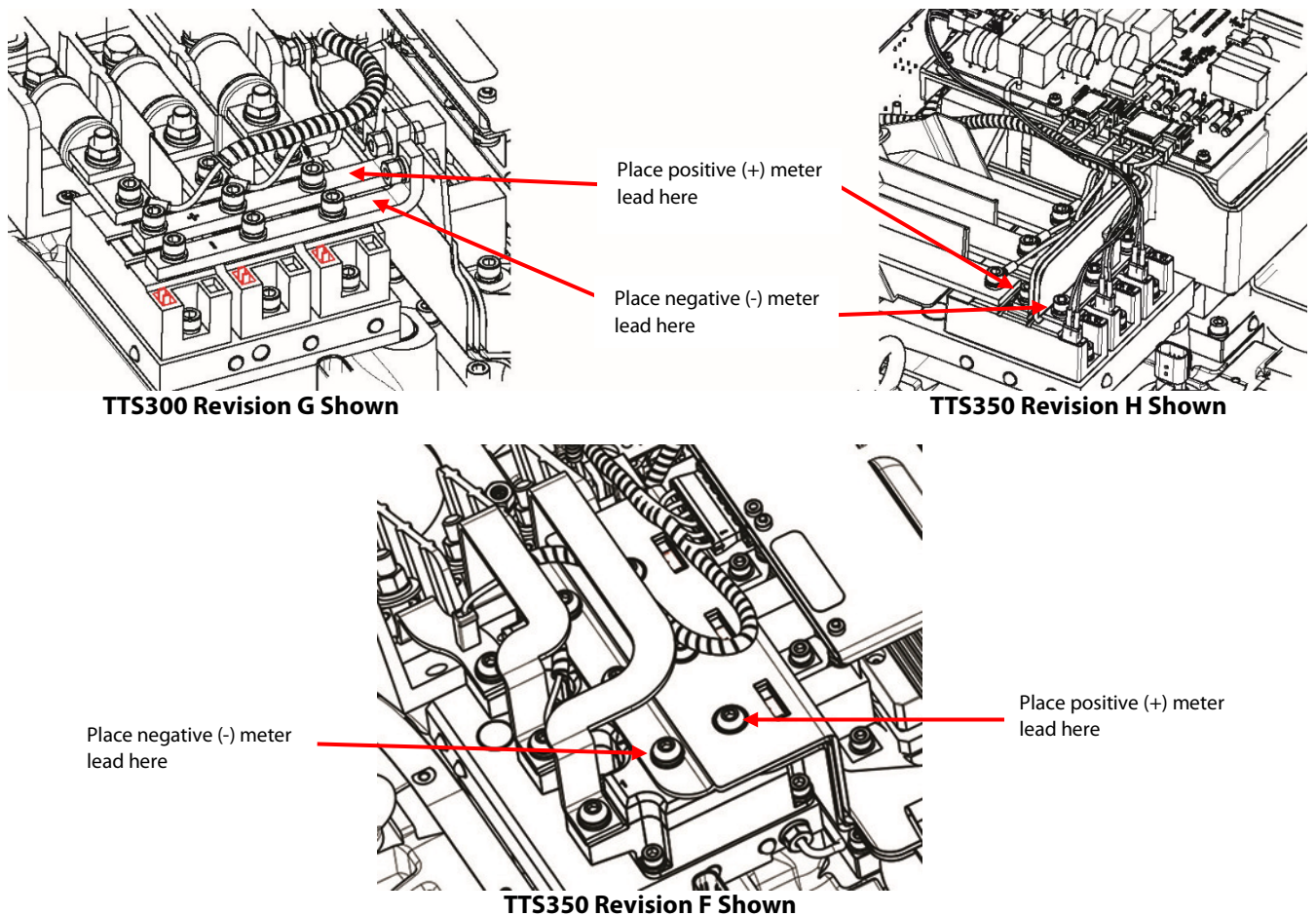

Figure 2 - DC Bus Voltage Test Points

3 - Relief Membrane Removal

The Relief Membrane is used to seal the lower area of the DC Capacitors. It is designed to relieve pressure should an internal component fail, such as the Inverter and DC Capacitor. If an internal component does fail and there is a sudden increase in pressure within the covers, the Relief Membrane has flaps that will allow the pressure to escape without damaging the compressor covers.

1. Isolate compressor power as described in the "Electrical Isolation" section above prior to performing any service procedures.
2. Remove the nylon nuts under the DC Capacitor Bus Bar Assembly, then remove the Relief Membrane.

4 - Relief Membrane Installation

1. Install the Relief Membrane with the foam side up.
2. Install the nylon nuts to the base of the DC Capacitor Bus Bar Assembly, under the main compressor housing.
3. When properly installed, the Relief Membrane should be visible with the Capacitor Cover installed.
4. Install the top covers.
5. Return the compressor to normal operation.

5 - Kit Contents:

Note: Any part numbers included in the kit contents are internal part numbers only. Please refer to our Spare Parts Manuals for any kit part numbers.

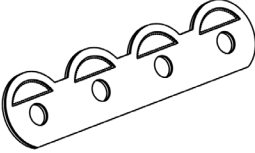

Kit number: 100122		
QTY	Part(s) Description	Picture(s)
4	JAM NUT, HEX	
1	MEMBRANE, CAPACITOR RELIEF	

6 - List of Changes

Revision	Date	Description of Change
A	3/8/2023	New

Danfoss LLC can accept no responsibility for possible errors in catalogues, brochures, and other printed material. Danfoss reserves the right to alter its products without notice. This also applies to products already on order provided that such alterations can be made without subsequential changes being necessary in specifications already agreed. All trademarks in this material are property of the respective companies. Danfoss and the Danfoss logotype are trademarks of Danfoss A/S. All rights reserved.