

Customer Notification

B-CN-314-EN REV A

May 25, 2023

SUBJECT: TT Series Cover Screw Torque

Purpose

This is to inform Danfoss customers that we have updated the torque specification for our TT Series Compressor cover fasteners. Our Service Manual previously stated the torque for the cover screws was 1.5 Nm. The new torque specification is now 2.5 Nm (22 in.lb.).

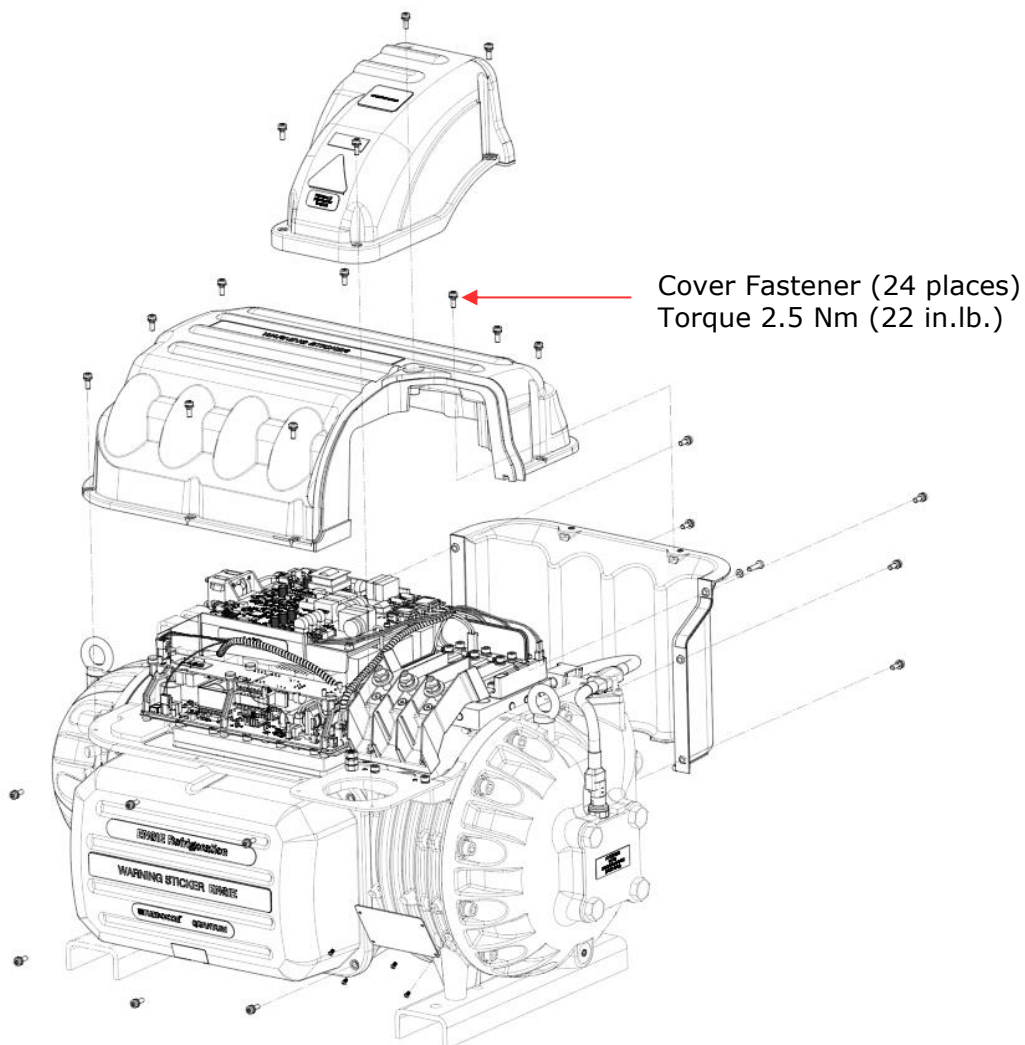

Figure 1 – Cover Screw Torque

Summary

We have updated our TT Series Cover fastener torque specifications to 2.5 Nm (22 in.lb.). This updated torque specification applies to all four (4) covers.

Action Required

When installing any TT Series Compressor cover, torque the fasteners to 2.5 Nm (22 in.lb.).

Need Assistance

For more information, please contact your Key Account Manager or our Product Support group at turbocor.ps.na@danfoss.com.

Classified as Business

Danfoss LLC • 1769 E Paul Dirac Drive • Tallahassee, FL 32310 USA • turbocor.ps.na@danfoss.com • <http://turbocor.danfoss.com> • Phone +1 850 504 4800

Danfoss LLC can accept no responsibility for possible errors in catalogues, brochures, and other printed material. Danfoss reserves the right to alter its product without notice. This also applies to products already on order provided that such alterations can be made without sub-sequential changes being necessary in specifications already agreed. All trademarks in this material are property of the respective companies. Danfoss and the Danfoss logotype are trademarks of Danfoss A/S. All rights reserved